



DENTAL

DENTALINSTRUMENTE

DENTAL INSTRUMENTS

INSTRUMENTS DENTAIRES

INSTRUMENTOS DENTALES

STRUMENTI DENTALI



[DAS UNTERNEHMEN]

„Mit unseren Instrumenten wird nicht gespielt, sie retten Leben.“

„Our instruments are not to play, they save lifes.“

„Nos instruments ne sont pas pour jouer, ils sauvent des vies.“

„Con nuestro instrumental no se juega, se rescata vida.“

„Non giochiamo con nostri strumenti, salvano la vita.“

[DEUTSCH]

Seit 1976 sind wir erfolgreich in der Medizinbranche tätig. Wir bieten ein komplettes Programm chirurgischer Instrumente an. Im Mittelpunkt aller Maßnahmen und Aktivitäten unseres Hauses steht der Kunde. Seine Wünsche, Ansprüche und Anforderungen sind für uns eine tägliche Herausforderung. Deshalb ist absolute Kundenorientierung für uns oberstes Prinzip. Sie prägt unsere Geschäftspolitik und ist jederzeit Ansporn für das Handeln und Denken unserer Mitarbeiter. Daher sind wir stets für morgen gerüstet. Unser Qualitätsmanagement ist ein essentieller Bestandteil unserer langfristigen Unternehmensstrategie, in die jeder einzelne Mitarbeiter eingebunden ist und die von einem Wir-Gefühl getragen wird. Unabhängig vom jeweiligen Arbeitsplatz, fühlt sich jeder DIMEDA-Mitarbeiter für die Einhaltung der Qualität verantwortlich.

Wir verfügen über modernste Logistik. Unser umfassendes Lager garantiert schnelle Lieferzeiten. Sollten Artikel nicht lagermäßig vorrätig sein, so können diese durch einen speziellen Service kurzfristig zur Verfügung gestellt und versendet werden. Alle Instrumente und Geräte aus unserem Sortiment werden von geschulten und erfahrenen Fachkräften mit handwerklichem Geschick unter Einsatz modernster Maschinen und Anlagen hergestellt. Dabei kommen ausnahmslos Materialien zum Einsatz, die unseren besonders hohen Qualitätsstandards genügen. Unsere Produktpalette mit mehr als 23.000 verschiedenen Standardinstrumenten für die Human-, Dental und Veterinärmedizin wird durch die enge Zusammenarbeit mit unseren Kunden, Ärzten und Wissenschaftlern im In- und Ausland ständig erweitert und nach dem neuesten Stand der Technik optimiert.

[ENGLISH]

Since 1976 we have been working successfully in the medical field. The focus of all our measures and activities is the customer. His wishes, demands and requirements are a daily challenge for us. Therefore, customer service is our top priority. It effects our business policy and is a permanent task for every member of our team. For this reason we are prepared for the future at any time. Our Quality Management is an essential component in our long-term company strategy in which every single employee is involved and which is supported by a common feeling. Every DIMEDA employee feels himself responsible for observance of quality no matter in which department he is working.

Our extensive warehouse guarantees quick delivery times. Articles which are not available ex stock can be supplied in a short time due to a special service. All instruments and devices of our product range are manufactured by well-trained and experienced skilled workers with special craftsmanship and by use of most modern machines and equipment. We only use materials which meet our high quality standards. Our product range with more than 23,000 different standard instruments for Human, Dental and Veterinary medical applications is permanently increased and optimized as per the state of the art by the close cooperation of our domestic and foreign customers, physicians and scientists.

[FRANÇAIS]

Depuis 1976, nous travaillons avec succès dans le secteur médical. Nous offrons une gamme complète d'instruments chirurgicaux. Le client est au centre de toutes les opérations et activités de notre maison. Ses souhaits, demandes et exigences sont pour nous un défi quotidien. C'est pourquoi nous avons pour principe suprême une orientation totale vers le client. Cette orientation marque fortement notre politique commerciale et représente une motivation constante de l'action et réflexion de nos collaborateurs. De ce fait, nous préparons d'une manière continue l'avenir. Notre management de qualité est un composant essentiel de notre stratégie d'entreprise à long terme, dans laquelle chaque collaborateur est intégré et qui est marqué par un fort esprit d'équipe. Quelque soit le poste de travail, chaque collaborateur de DIMEDA se sent responsable pour la qualité des produits.

Nous disposons d'une logistique la plus moderne. Notre vaste stock garantit une livraison prompte. Les articles non disponibles peuvent être mis à disposition par un service spécial et expédiés très rapidement. Tous nos instruments et appareils sont fabriqués par un personnel bien formé et expérimenté, faisant preuve d'un grand savoir-faire artisanal associé aux machines et aux installations les plus modernes. Il va de soi que pour un résultat optimal, nous utilisons seulement des matériaux qui répondent aux standards de qualité particulièrement élevés. Notre gamme de produits se compose de plus de 23.000 instruments standards pour la médecine humaine, dentaire et vétérinaire. Elle s'élargit constamment grâce à l'étroite collaboration entre nos clients, des chirurgiens et des scientifiques en Allemagne et à l'étranger en appliquant les techniques les plus nouvelles.

[ESPAÑOL]

Desde 1976 trabajamos con éxito en la rama medicinal. Ofertamos completamente el instrumental quirúrgico. El objetivo de todas diligencias y actividades es la satisfacción de nuestros clientes. Sus deseos, demandas y requerimientos constituye nuestro reto diario. Por esta razón, el servicio al cliente es la premisa principal en nuestra casa, marca nuestra política empresarial y representa un constante estímulo en las tareas de todos los empleados. Por ello, nos hemos preparado para el día de mañana. La administración de cualidad es un pilar muy importante en nuestra estrategia empresarial. Todos y cada uno de los empleados se identifican con esta filosofía. Independiente de la función en la empresa, se siente cada empleado de DIMEDA responsable de su cumplimiento.

Disponemos una logística de las más modernas. Nuestro almacén extenso garantiza un despacho rápido. Sino tenemos un artículo disponible, podemos facilitar y mandarlo en corto plazo por un servicio especial. Todos nuestros productos son fabricados por personal especializado y experto con máquinas e instalaciones de las más modernas. En ello usamos sin excepción materiales, que cumplen con nuestro estándar de alta calidad. Nuestra gama de productos abarca más de 23.000 diferentes instrumentos generales para la medicina humana, dental y veterinaria. A través de estrechas relaciones con nuestros clientes, cirujanos y científicos en todo el mundo, actualizamos y ampliamos constantemente nuestra técnica.

[ITALIANO]

Dal 1976 siamo attive nel campo di medicina con molto successo. Offriamo un programma completo di strumenti chirurgici. In primo luogo viene per noi il cliente. I suoi desideri, le esigenze, le richieste sono per noi una continua sfida giornaliera. Per questo è per noi supremo principio l'orientamento della nostra clientela. Caratterizzano gli affari politici stimolano di più il modo di pensare e trattare dei nostri collaboratori. Per questo siamo sempre per il domani attrezzati. Nostra qualità totale è un importante elemento a lungo tempo per la strategia dell'impresa. Ogni collaboratore è incluso con una sensibilità insieme. Uguale che lavoro fanno il personale di DIMEDA sono responsabile per la qualità.

Noi disponiamo di una logistica moderna. Il nostro magazzino garantisce una consegna veloce. Caso mai non sono disponibili possiamo con un servizio speciale spedirli in breve termine. Tutti strumenti del nostro assortimento vengono fatti da persone competenti con un talento professionale con un impianto di macchine moderne. In cui inseriamo materiale che è sufficiente per il nostro particolare grado di qualità. Il nostro gamma di prodotti con più di 23.000 diversi strumenti standard per la medicina Uomo-, Dental-, e Veterinari attraverso la nostra collaborazione con la clientela con persone pratiche è scienziati nel interne westero siamo in continua estensione è ci completiamo sul nuovo livello tecnico.

[LOGISTIK]

„Einmal um die ganze Welt.“

„All around the world.“

„Une fois autour du monde.“

„Recorrer el mundo entero.“

„Una volta attorno al mondo.“

[D]

Seit 40 Jahren nutzen Ärzte weltweit unsere chirurgischen Instrumente. Es gibt kaum ein Land, in dem wir nicht vertreten sind. Von unserem Lager bis zu ihrem Bestimmungsort hat unsere Ware oft einen langen Weg hinter sich. Wir setzen logistisch alles daran, dass Ihre Bestellung rechtzeitig und zu Ihrer Zufriedenheit eintrifft.

[E]

Since 40 years physicians and surgeons all over the world are using our surgical instruments. There is hardly a country where we do not have a distributor. It is often a long way before our goods reach their final destination from our stock. We do our utmost that your order arrives in time and to your entire satisfaction.

[F]

Depuis 40 ans nos instruments chirurgicaux sont utilisés mondialment dans le secteur médical. Il y a peu de pays où nous ne sommes représentés. De notre dépôt à sa destination, notre marchandise parcourt souvent une grande distance. Nous nous efforçons logistiquement de livrer votre commande à temps, et à votre entière satisfaction.

[ES]

Hace 40 años usan los médicos nuestros instrumentos quirúrgicos en todo el mundo. No hay casi ninguna tierra, en que no estamos representados. Desde nuestro almacén hasta el destino final, se deja la mercancía muchas veces un camino largo. Hacemos todo lo posible, que su pedido llegue a punto y a su satisfacción.

[I]

Da 40 anni i dottori usano nostri strumenti chirurgici, in tutto il mondo. Non c'è quasi un paese dove non siamo presenti. Dal nostro magazzino fino tuo posto, il prodotto ha una lunga strada. Siamo presenti di consegnare in tempo e soddisfarvi.



[QUALITÄT]

„Unsere Produkte unterliegen internationalen Standards.“

„Our products are subject to international standards.“

[D]

Alle DIMEDA Produkte erfüllen die grundlegenden Anforderungen der EG-Richtlinie 93/42/EWG und werden somit mit dem CE-Zeichen gekennzeichnet. Unser Qualitätsmanagementsystem ist nach der DIN EN ISO 13485:2012 + AC:2012 zertifiziert, und die Einhaltung internationaler Normen, wie z.B. der FDA, steht für uns an höchster Stelle. Da unsere Produkte verschiedene Qualitätskontrollen durchlaufen, ist jedes Instrument mit individueller Handarbeit verbunden.

[E]

All DIMEDA products comply with the basic requirements of the EC Directive 93/42/EWG and have thus the CE mark. Our Quality Management System is certified according to DIN EN ISO 13485:2012 + AC:2012. The compliance with international standards, like for instance those of the FDA, has the highest priority for us. Every single product has to pass several quality checks and thus is individually treated by hand.



„Nos produits sont soumis aux standards internationaux.“

[F]

Tous les produits DIMEDA correspondent aux exigences des directives de la CE 93/42/EWG et sont donc signalés avec le marquage CE. Notre système de gestion de la qualité est certifié d'après DIN EN ISO 13485:2012 + AC:2012, et le respect des normes internationales comme par exemple celle de la FDA est pour nous primordial. Comme nos produits traversent de contrôles divers de qualité, chaque instrument représente un travail manuel individuel.

„Nuestros productos están bajo estándar internacional.“

[ES]

Todos los productos de DIMEDA cumplen los requisitos básicos de las directivas CE 93/42/EWG y por tanto se marcan con la marca CE. Nuestro sistema de calidad esta certificado por las normas de DIN EN ISO 13485:2012 + AC:2012, además el cumplimiento de las normas internacionales, como la FDA, tiene nuestra máxima prioridad. Como nuestros productos pasan por diferentes controles de calidad, todo el instrumental esta conectado con mano de obra individualmente.

„Nostrì prodotti rispondono alle norme internazionali.“

[I]

Tutti prodotti di Dimeda, conferma le condizioni del EG 93/42/EWG e sono identificati con CE. Il nostro sistema di qualità è certificata, di DIN EN ISO 13485:2012 + AC:2012 e conferma alle norme internazionali come la FDA, sta per noi al punto più alto. Nostrì prodotti hanno diversi controlli di qualità, perciò ognuno è collegato con lavoro fatto a mano.

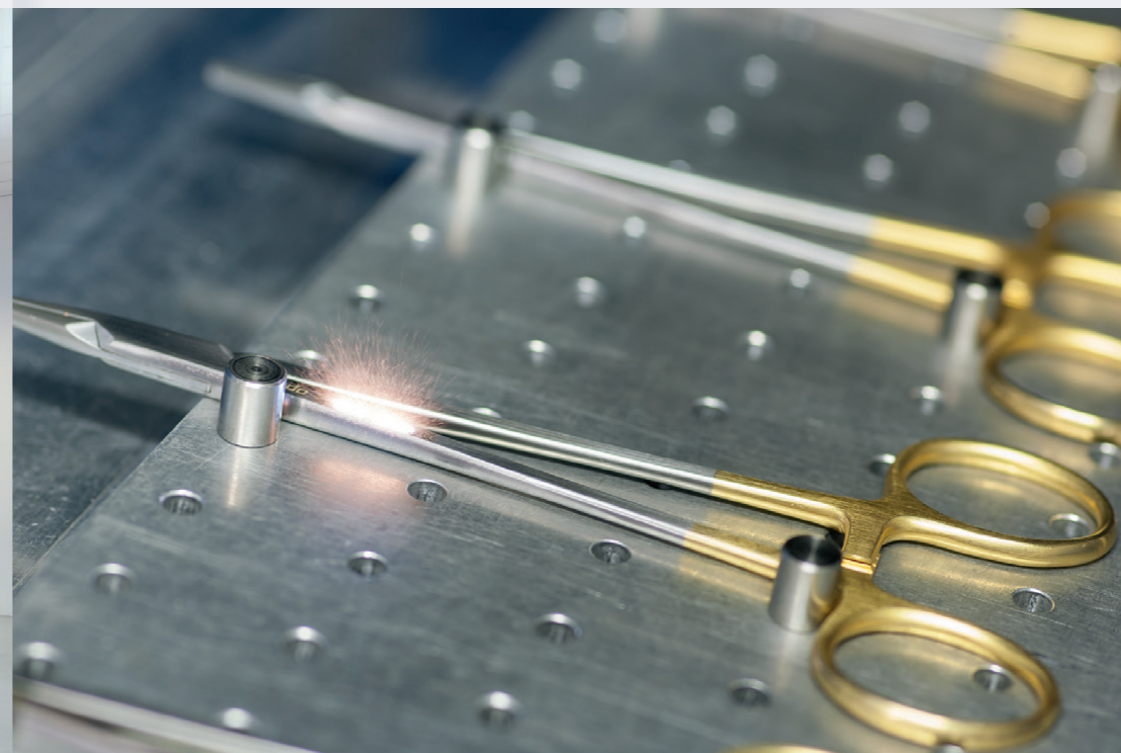

[ORIENTIERUNG]

„Schnell suchen,
schneller finden.“

„Search fast, find faster.“

„Chercher vite, trouver
plus rapidement.“

„Búsqueda rápida,
encuentro más rápido.“

„Cercare veloce,
trovare più veloce.“

[D]

[E]

Damit Sie schneller genau das Produkt finden, welches Sie suchen, finden Sie hier eine detaillierte Beschreibung zu Bildern, Artikelnummern sowie weiteren Angaben.

In order to help you to find the product you are looking for faster, you have here a detailed description to images, part numbers as well as additional information.

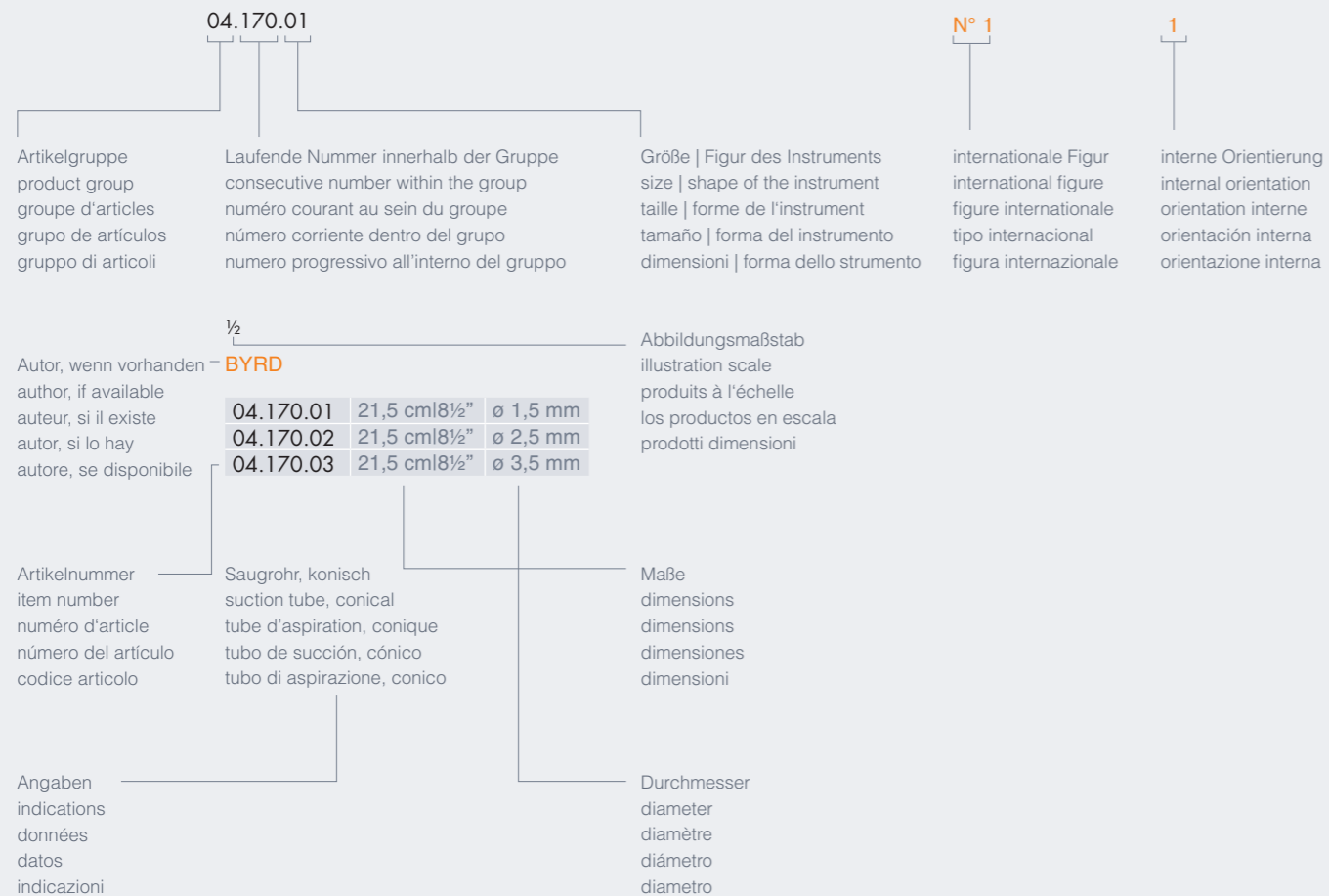

[F]

[ES]

[I]

Pour que vous puissiez trouver rapidement ce que vous cherchez, vous trouverez sur cette page une description détaillée concernant les images, numéros d'articles et d'autres données.

Para que usted encuentre el producto deseado más rápido, tiene aquí una descripción detallada de las imágenes, números de los artículos así como más informaciones.

Per trovare veloce il prodotto, avete qua una descrizione dettagliata per le foto, il codice e altre informazioni.



[ORIENTIERUNG]

„Schnell suchen,
schneller finden.“

Durchmesser
diameter
diamètre
diámetro
diametro

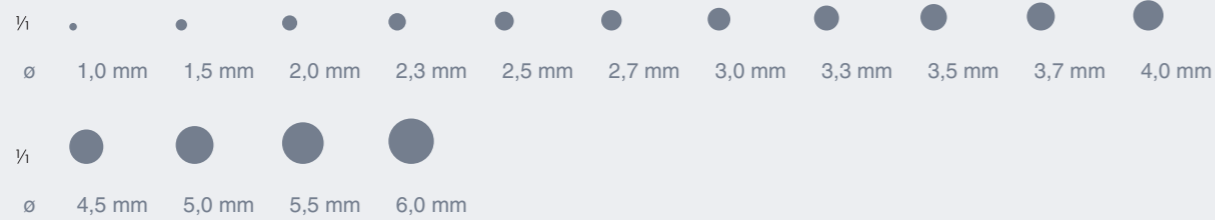

gerades Instrument straight instrument instrument droit instrumento recto strumento retto	gebogenes Instrument curved instrument instrument courbé instrumento curvo strumento curvo	gewinkelt angled coudé angulado angolato	scharfes Instrument sharp instrument instrument aigu instrumento agudo strumento acuto	stumpfes Instrument blunt instrument instrument émoussé instrumento romo strumento smusso	diamantiertes Maul diamond coated jaws mors diamanté boca diamantada morso diamantato
mit Sperre with lock avec serrure con cierre con fermo	konisch conical conique cónico conico	kurz short court corto corto	fein schmal delicate narrow délicat étroit fino estrecho delicato stretta	sehr fein very delicate très délicat muy fino molto delicato	eine Schneide gezahnt one toothed cutting edge une lame dentelée una hoja dentada una lama dentata
stumpf stumpf blunt blunt émoussé émoussé romo romo smusso smusso	spitz stumpf pointed blunt pointu émoussé agudo romo acuto smusso	spitz spitz pointed pointed pointu pointu agudo agudo acuto acuto	streamline streamline pointu pointu streamline streamline	s-förmig s-shaped forme s forma s forma s	zwei Schneiden gezahnt two toothed cutting edges deux lames dentelées dos hojas dentadas due lame dentate

mit TC-Einsätzen TC inserts à mors TC con bocas TC con morso TC	TC Schneiden TC cutting edges tranchant TC corte TC taglio TC	Titan titanium titane titanio titanio









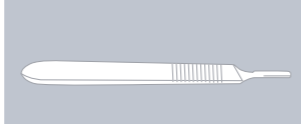
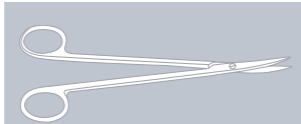

Anzahl der Zähne number of teeth quantité de dents cantidad de dientes quantità di denti	De Bakey-Zahnung De Bakey serration dentelure De Bakey dentado De Bakey dentatura De Bakey	Atrauma-Zahnung atraumatic serration dentelure atraumatique dentado atrauma dentatura atraumatica







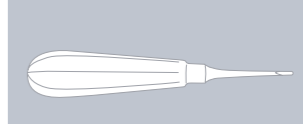
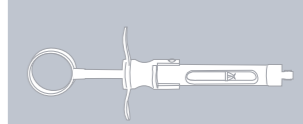

Normalprofil regular profile profil régulier perfil regular profilo regolare	Miniprofil mini profile profil mini perfil mini profilo mini	Mikroprofil micro profile profil micro perfil micro profilo micro

Sechskant hexagon hexagonal hexagonal esagono	Achtkant octagonal octogonal octogonal octagono	rund round rond redondo rotondo

L x B x H
Außenmaß - Länge x Breite x Höhe
outside dimension - length x width x height
dimension extérieure - longueur x largeur x hauteur
dimensión exterior - longitud x anchura x altura
dimensione esteriore - lunghezza x ampiezza x altezza



01	SAUGROHRE SUCTION TUBES TUBES D'ASPIRATION TUBOS DE ASPIRACIÓN TUBI DI ASPIRAZIONE		1 - 4
02	SKALPELLE & MESSER SCALPEL & KNIVES BISTOURIS & COUTEAUX BISTURÍ Y CUCHILLOS BISTURI & COLTELLI		5 - 10
03	SCHEREN SCISSORS CISEAUX TIJERAS FORBICI		11 - 26
04	PINZETTEN FORCEPS PINCES PINZAS PINZE		27 - 38
05	ARTERIENKLEMMEN HEMOSTATIC FORCEPS PINCES HÉMOSTATIQUES PINZAS HEMOSTÁTICAS PINZE EMOSTATICHE		39 - 44
06	WUNDHAKEN RETRACTORS ECARTEURS SEPARADORES DIVARICATORI		45 - 52
07	NADELHALTER NEEDLE HOLDERS PORTE-AIGUILLES PORTA-AGUJAS PORT'AGHI		53 - 60
08	ORTHOPÄDIE ORTHOPAEDICS ORTHOPÉDIE ORTOPEDIA ORTOPEDIA		61 - 80
09	KNOPFSONDEN PROBES SONDES BOUTONNÉES SONDAS ABOTONADAS SONDE A BOTTONE		81 - 82
10	MUND UND ZUNGE MOUTH AND TONGUE BOUCHE ET LANGUE BOCA Y LENGUA BOCCA E LINGUA		83 - 90
11	ZAHNZANGEN EXTRACTING FORCEPS DAVIERS PINZAS PINZE		91 - 126
12	KINDERZAHNZANGEN EXTRACTING FORCEPS FOR CHILDREN DAVIERS POUR ENFANTS PINZAS DE EXTRACCIÓN PARA NIÑOS PINZE PER ESTRAZIONE PER BAMBINI		127 - 138

13	WURZELHEBER ROOT ELEVATORS ELÉVATEURS DE RACINES ELEVADORES PARA RAÍCES LEVE PER RADICI		139 - 154
14	AMPULLENSPRITZEN CARTRIDGE SYRINGES SERINGUES POUR AMPOULE JERINGAS DE CARTUCHO SIRINGE DI CARPULE		155 - 160
15	MUNDSPIEGEL MOUTH MIRRORS MIROIRS DENTAIRES ESPEJOS DE BOCA SPECCHIETTI DI BOCCA		161 - 166
16	PARODONTOLOGIE PERIODONTOLOGY PARODONTOLOGIE PARODONTOLOGÍA PARODONTOLOGIA		167 - 190
17	FÜLLUNGSINSTRUMENTE FILLING INSTRUMENTS INSTRUMENTS POUR PLOMBAGES INSTRUMENTOS PARA OBTURACIONES OTTURATORI		191 - 208
18	PROTHETIK PROSTHETICS PROTHÈSES PRÓTESIS PROTESI		209 - 222
19	TECHNIKZANGEN MEDICAL PLIERS PINCES PROTHÉTIQUES PINZA PARA TÉCNICA TENAGLIE PER TECNICA		223 - 236
20	HYGIENE HYGIENE HIGIENNE HYGIÈNE IGIENE		237 - 242
21	VERSCHIEDENES MISCELLANEOUS DIVERS DIVERSOS DIVERSI		243 - 246
22	HOCHFREQUENZ-CHIRURGIE HIGH FREQUENCY SURGERY CHIRURGIE À HAUTE FRÉQUENCE ELECTROCIRUGÍA ELETTROCHIRURGIA		247 - 250
23	NUMMERISCHES VERZEICHNIS NUMERICAL INDEX INDEX NUMÉRIQUE ÍNDICE NUMÉRICO INDICE NUMERICO		251 - 256
24	INHALTSVERZEICHNIS ALPHABETIC INDEX INDEX ALPHABÉTIQUE ÍNDICE ALFABÉTICO INDICE ALFABETICO		257 - 276

01

SAUGROHRE
SUCTION TUBES
TUBES D'ASPIRATION
TUBOS DE ASPIRACIÓN
TUBI DI ASPIRAZIONE





½

COUPLANT AUFSATZ

04.165.01	9 cm 3½"	ø 1,5 mm
04.165.02	9 cm 3½"	ø 2,0 mm
04.165.03	9 cm 3½"	ø 2,5 mm
04.165.04	9 cm 3½"	ø 3,5 mm
04.165.11	9 cm 3½"	ø 1,5 mm
04.165.12	9 cm 3½"	ø 2,0 mm
04.165.13	9 cm 3½"	ø 2,5 mm
04.165.14	9 cm 3½"	ø 3,5 mm

Spitze seitlich perforiert
tip laterally perforated
pointe côté perforée
punta perforada lateralmente
punta con perforazione laterale



½

COUPLAND

04.165.00	16,5 cm 6½"
-----------	---------------



½

BYRD

04.170.01	21,5 cm 8½"	ø 1,5 mm
04.170.02	21,5 cm 8½"	ø 2,5 mm
04.170.03	21,5 cm 8½"	ø 3,5 mm



½

04.171.15	14 cm 5½"	ø 1,5 mm
04.171.02	14 cm 5½"	ø 2,0 mm
04.171.25	14 cm 5½"	ø 2,5 mm
04.171.03	14 cm 5½"	ø 3,0 mm
04.171.04	14 cm 5½"	ø 4,0 mm
04.171.05	14 cm 5½"	ø 5,0 mm
04.171.06	14 cm 5½"	ø 6,0 mm

04.172.15	17 cm 6¾"	ø 1,5 mm
04.172.02	17 cm 6¾"	ø 2,0 mm
04.172.25	17 cm 6¾"	ø 2,5 mm
04.172.03	17 cm 6¾"	ø 3,0 mm
04.172.04	17 cm 6¾"	ø 4,0 mm
04.172.05	17 cm 6¾"	ø 5,0 mm
04.172.06	17 cm 6¾"	ø 6,0 mm

Saugkanülen mit Unterbrecher und Mandrin
suction cannula with finger cut-off and stylet
canules d'aspiration avec interrupteur à doigt et stylet
cánulas para aspiración con interruptor y estilete
cannule per aspirazione con interruttore e stiletto



½

FRAZIER 19 cm | 7½"

40.295.06	30° 12,5 cm 5"	ø 2,0 mm
40.295.07	30° 12,5 cm 5"	ø 2,3 mm
40.295.08	30° 12,5 cm 5"	ø 2,7 mm
40.295.09	30° 12,5 cm 5"	ø 3,0 mm
40.295.10	30° 12,5 cm 5"	ø 3,3 mm
40.295.11	30° 12,5 cm 5"	ø 3,7 mm
40.295.12	30° 12,5 cm 5"	ø 4,0 mm
40.295.15	30° 12,5 cm 5"	ø 5,0 mm

40.297.06	75° 12,5 cm 5"	ø 2,0 mm
40.297.07	75° 12,5 cm 5"	ø 2,3 mm
40.297.08	75° 12,5 cm 5"	ø 2,7 mm
40.297.09	75° 12,5 cm 5"	ø 3,0 mm
40.297.10	75° 12,5 cm 5"	ø 3,3 mm
40.297.11	75° 12,5 cm 5"	ø 3,7 mm
40.297.12	75° 12,5 cm 5"	ø 4,0 mm
40.297.15	75° 12,5 cm 5"	ø 5,0 mm



½

FERGUSSON 18,5 cm | 7¼"

40.270.15	11 cm 4¼"	ø 1,5 mm
40.270.20	11 cm 4¼"	ø 2,0 mm
40.270.25	11 cm 4¼"	ø 2,5 mm
40.270.30	11 cm 4¼"	ø 3,0 mm
40.270.40	11 cm 4¼"	ø 4,0 mm
40.270.50	11 cm 4¼"	ø 5,0 mm

FERGUSSON 20,5 cm | 8"

40.271.15	13 cm 5"	ø 1,5 mm
40.271.20	13 cm 5"	ø 2,0 mm
40.271.25	13 cm 5"	ø 2,5 mm
40.271.30	13 cm 5"	ø 3,0 mm
40.271.40	13 cm 5"	ø 4,0 mm
40.271.50	13 cm 5"	ø 5,0 mm



½

ADSON

40.290.21 21 cm | 8¼" ø 4 mm



½

PLESTER

40.313.15	19,5 cm 7¾"	ø 1,5 mm
40.313.20	19,5 cm 7¾"	ø 2,0 mm
40.313.25	19,5 cm 7¾"	ø 2,5 mm
40.313.30	19,5 cm 7¾"	ø 3,0 mm

für Schlauch mit ø 6 - 9 mm
 for tube with ø 6 - 9 mm
 pour tuyau de ø 6 - 9 mm
 para tubo con ø 6 - 9 mm
 per tubo con ø 6 - 9 mm



½

40.294.05 18 cm | 7" ø 5 mm

für Schlauch mit ø 6 - 9 mm
 for tube with ø 6 - 9 mm
 pour tuyau de ø 6 - 9 mm
 para tubo con ø 6 - 9 mm
 per tubo con ø 6 - 9 mm



½

LUER 16,5 cm | 6½"

40.282.30	11 cm 4¼"	ø 3,0 mm
40.282.35	11 cm 4¼"	ø 3,5 mm
40.282.45	11 cm 4¼"	ø 4,5 mm

Saugrohr, konisch
 suction tube, conical
 tube d'aspiration, conique
 tubo de succión, cónico
 tubo di aspirazione, conico

02

SKALPELLE & MESSER
 SCALPELS & KNIVES
 BISTOURIS & COUTEAUX
 BISTURIS & CUCHILLOS
 BISTURI & COLTELLI





SKALPELLGRIFFE & STERILE SKALPELLKLINGEN
 SCALPEL HANDLES & STERILE SCALPEL BLADES
 MANCHES DE BISTOURI & LAMES DE BISTOURI STÉRILES
 MANGOS DE BISTURÍ & HOJAS DE BISTURÍ ESTÉRILES
 MANICI PER BISTURI & LAME DA BISTURI STERILI

100 Stück
 100 pieces
 100 pièces
 100 piezas
 100 pezzi

passend für
 for
 allant avec
 para
 per
 N° 3, N° 3R, N° 5, N° 7, N° 7K

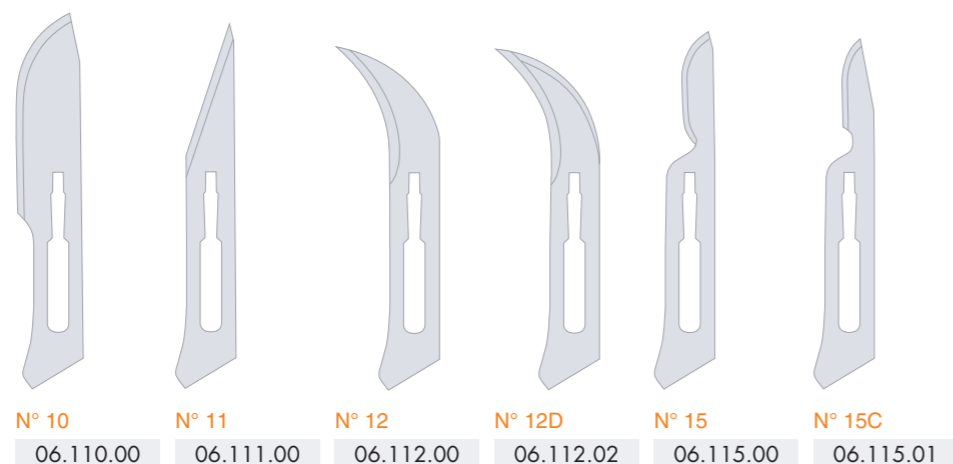

N° 10 06.110.00 N° 11 06.111.00 N° 12 06.112.00 N° 12D 06.112.02 N° 15 06.115.00 N° 15C 06.115.01



1/2
 N° 3 06.103.00 12 cm 4 3/4" N° 3 06.103.01 12 cm 4 3/4" N° 3 06.103.11 12 cm 4 3/4"

Graduierung in cm
 cm graduation
 graduation en cm
 graduado en cm
 graduato in cm

Zentimeter- und Zollgraduierung
 cm and inch graduation
 graduation en cm et pouces
 graduación en cm y pulgadas
 graduazione in cm e pollici



1/2
 N° 3R 06.103.03 14,5 cm 5 3/4"



1/2
 N° 3R 06.103.33 14 cm 5 1/2" N° 3R 06.103.15 15 cm 6"



1/2
 N° 3R 06.103.15 15 cm 6"



1/2
 N° 5 06.105.00 16 cm 6 1/4" N° 7 06.107.00 16 cm 6 1/4" N° 7K 06.107.01 12,5 cm 5"



SKALPELLGRIFFE & STERILE SKALPELLKLINGEN
 SCALPEL HANDLES & STERILE SCALPEL BLADES
 MANCHES DE BISTOURI & LAMES DE BISTOURI STÉRILES
 MANGOS DE BISTURÍ & HOJAS DE BISTURÍ ESTÉRILES
 MANICI PER BISTURI & LAME DA BISTURI STERILI



100 Stück
 100 pieces
 100 pièces
 100 piezas
 100 pezzi

passend für
 for
 allant avec
 para
 per
 N° 4



1/4

N° 4

06.104.00 13,5 cm | 5 1/4"



1/4

N° 4

06.104.01 13,5 cm | 5 1/4"

Graduierung in cm
 cm graduation
 graduation en cm
 graduado en cm
 graduato in cm



N° 18

06.118.00



N° 19

06.119.00



N° 20

06.120.00



N° 21

06.121.00



N° 22

06.122.00



N° 23

06.123.00



N° 24

06.124.00



N° 25

06.125.00



N° 36

06.136.00

10 Stück, steril
 10 pieces, sterile
 10 pièces, stériles
 10 piezas, estériles
 10 pezzi, sterile

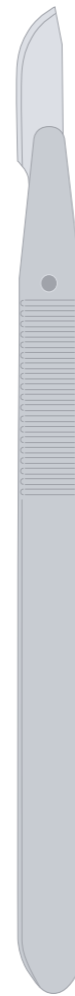

N° 10

06.210.00



N° 11

06.211.00



N° 12

06.212.00



N° 12D

06.212.02



N° 15

06.215.00



N° 15C

06.215.01



N° 18

06.218.00



N° 19

06.219.00



N° 20

06.220.00



N° 21

06.221.00



N° 22

06.222.00



N° 23

06.223.00



N° 24

06.224.00

MIKRO SKALPELLGRIFFE, MIKRO SKALPELLKLINGEN
 MICRO SCALPEL HANDLES, MICRO SCALPEL BLADES
 MICRO MANCHES POUR BISTOURIS, MICRO LAMES DE BISTOURI
 MICRO MANGOS DE BISTURÍ, MICRO HOJAS DE BISTURÍ
 MICRO MANICI PER BISTURI, MICRO LAME PER BISTURI



1/2
 06.199.14 14 cm15 1/2"



1/2
PARKER
 06.408.01 14 cm15 1/2"



1/2
PARKER
 06.408.02 14 cm15 1/2"

Skalpellingentferner
 scalpel blade remover
 detachelames de bistouris
 removedor para hojas de bisturí
 rimozione per le lame da bisturi

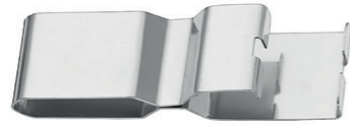

06.199.00 6 cm2 1/2"



1/4
 06.304.15 15,5 cm6"



1/4
 06.302.13 13,5 cm5 1/4"



1/4
 06.302.09 9,5 cm3 3/4"

10 Stück, steril
 10 pieces, sterile
 10 pièces, stériles
 10 piezas, estériles
 10 pezzi, sterile



40.859.01



40.859.02



40.859.04



40.859.05



40.859.07



40.859.09

03

SCHEREN
 SCISSORS
 CISEAUX
 TIJERAS
 FORBICI

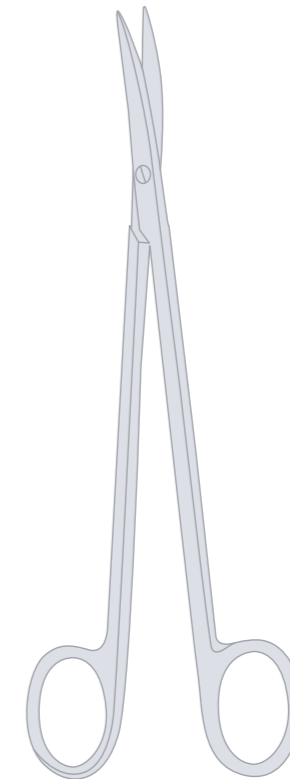



½

08.102.13	13 cm 5"		
08.103.13	13 cm 5"		
08.102.14	14,5 cm 5¾"		
08.103.14	14,5 cm 5¾"		



½

08.104.14	14,5 cm 5¾"			
08.105.14	14,5 cm 5¾"			



½

08.110.13	13 cm 5"		
08.111.13	13 cm 5"		
08.110.14	14,5 cm 5¾"		
08.111.14	14,5 cm 5¾"		



½

08.114.14	14,5 cm 5¾"			
08.115.14	14,5 cm 5¾"			



½

08.120.13	13 cm 5"		
08.121.13	13 cm 5"		
08.120.14	14,5 cm 5¾"		
08.121.14	14,5 cm 5¾"		



½

08.124.14	14,5 cm 5¾"			
08.125.14	14,5 cm 5¾"			



½

08.122.01	14,5 cm 5¾"			
08.122.02	14,5 cm 5¾"			
08.122.03	14,5 cm 5¾"			











½

08.123.01	14,5 cm 5¾"			
08.123.02	14,5 cm 5¾"			
08.123.03	14,5 cm 5¾"			







½

- 08.124.12 12 cm 4¾"  
- 08.125.12 12 cm 4¾"  
- 08.126.12 12 cm 4¾"  
- 08.127.12 12 cm 4¾"  







½

DEAVER

- 08.140.14 14 cm 5½"  
- 08.141.14 14 cm 5½"  













½

- 08.126.13 13 cm 5"  
- 08.127.13 13 cm 5"  



½





KELLY

- 08.540.16 16 cm 6¼"  
- 08.541.16 16 cm 6¼"  
- 08.542.16 16 cm 6¼"   
- 08.543.16 16 cm 6¼"   



½





JOSEPH

- 08.304.14 14 cm 5½"  
- 08.305.14 14 cm 5½"  



½







SANVENERO

- 08.302.14 14 cm 5½"  
- 08.303.14 14 cm 5½"  



½

JOSEPH

- 08.308.14 14 cm 5½"   
- 08.309.14 14 cm 5½"   

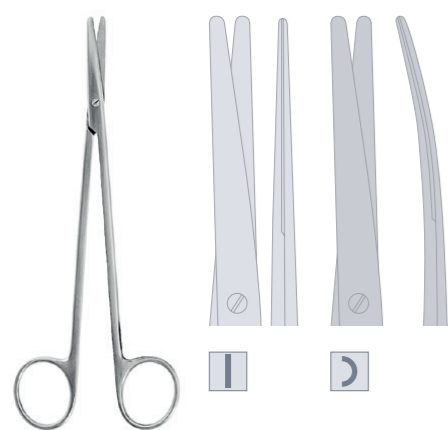

½

½

METZENBAUM

METZENBAUM

08.210.11	11,5 cm 4½"	▮	▲
08.211.11	11,5 cm 4½"	●	▲
08.280.15	14,5 cm 5¾"	▮	▲
08.281.15	14,5 cm 5¾"	●	▲
08.280.18	18 cm 7"	▮	▲
08.281.18	18 cm 7"	●	▲

08.284.11	11,5 cm 4½"	▮	▲	■
08.285.11	11,5 cm 4½"	●	▲	■
08.284.15	14,5 cm 5¾"	▮	▲	■
08.285.15	14,5 cm 5¾"	●	▲	■
08.284.18	18 cm 7"	▮	▲	■
08.285.18	18 cm 7"	●	▲	■



½

½

½

METZENBAUM

LEXER-FINO

DE BAKEY

08.278.14	14,5 cm 5¾"	▮	▲
08.279.14	14,5 cm 5¾"	●	▲
08.288.14	14,5 cm 5¾"	▮	▲
08.289.14	14,5 cm 5¾"	●	▲

08.196.16	16,5 cm 6½"	▮	▲
08.197.16	16,5 cm 6½"	●	▲

08.215.17	17,5 cm 7"	●	▲
-----------	------------	---	---

Arteriotomie-Schere
arteriotomy scissors
ciseaux d'artériotomie
tijeras de arteriotomía
forbici da arteriotomia

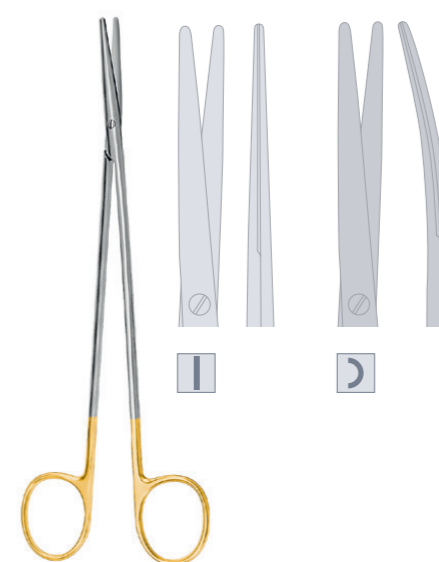
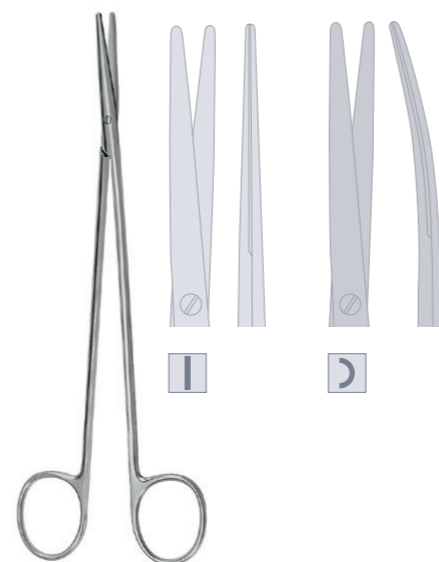

½

½

½

METZENBAUM-FINO

METZENBAUM-FINO

METZENBAUM-FINO

08.282.15	14,5 cm 5¾"	▮	▲
08.283.15	14,5 cm 5¾"	●	▲

08.286.15	14,5 cm 5¾"	▮	▲	■
08.287.15	14,5 cm 5¾"	●	▲	■

08.292.14	14,5 cm 5¾"	▮	▲
-----------	-------------	---	---



½

½

½

METZENBAUM-FINO

METZENBAUM-FINO

METZENBAUM-FINO

08.293.14	14,5 cm 5¾"	●	▲
-----------	-------------	---	---

08.296.14	14,5 cm 5¾"	▮	▲	■
-----------	-------------	---	---	---

08.297.14	14,5 cm 5¾"	●	▲
-----------	-------------	---	---



Nerv-Präparierschere
nerve dissecting scissors
ciseaux à préparation de nerf
tijeras para preparación del nervio
forbici per preparazione del nervo

½
08.582.15 15 cm|6"

½
08.583.15 15 cm|6"

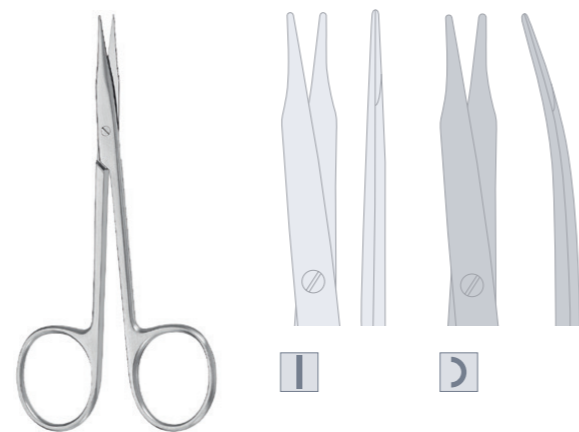

½
JAMESON-WERBER
08.584.13 13 cm|5"

½
JAMESON
08.584.15 15 cm|6"

½
08.306.11 11,5 cm|4½"

08.307.11 11,5 cm|4½"



½
TOENNIS-ADSON
08.609.17 17,5 cm|7"

½
TOENNIS-ADSON
08.609.18 17,5 cm|7"

½
TOENNIS-ADSON
08.613.17 17,5 cm|7"



½
KILNER
08.310.12 12 cm|4¾"

08.310.15 15 cm|6"

½
KILNER
08.314.12 12 cm|4¾"

08.314.15 15 cm|6"

½
REYNOLDS
08.321.15 15 cm|6"

08.321.18 18 cm|7"



IRISSCHEREN
 IRIS SCISSORS
 CISEAUX À IRIDECTOMIE
 TIJERAS PARA IRIDECTOMÍA
 FORBICI PER IRIDECTOMIA



- ½
IRIS
- | | | | |
|-----------|-------------|--|---|
| 08.340.09 | 9 cm 3½" | | ▲ |
| 08.340.10 | 10,5 cm 4¼" | | ▲ |
| 08.340.11 | 11,5 cm 4½" | | ▲ |
| 08.340.12 | 12,5 cm 5" | | ▲ |



- ½
IRIS
- | | | | |
|-----------|-------------|---|---|
| 08.341.09 | 9 cm 3½" | ⌋ | ▲ |
| 08.341.10 | 10,5 cm 4¼" | ⌋ | ▲ |
| 08.341.11 | 11,5 cm 4½" | ⌋ | ▲ |
| 08.341.12 | 12,5 cm 5" | ⌋ | ▲ |



- ½
IRIS
- | | | | | |
|-----------|-------------|--|---|---|
| 08.344.11 | 11,5 cm 4½" | | ■ | ▲ |
|-----------|-------------|--|---|---|



- ½
IRIS
- | | | | | |
|-----------|-------------|---|---|---|
| 08.345.11 | 11,5 cm 4½" | ⌋ | ■ | ▲ |
|-----------|-------------|---|---|---|



- ½
IRIS
- | | | | |
|-----------|-------------|---|---|
| 08.351.11 | 11,5 cm 4½" | ⌋ | ▲ |
|-----------|-------------|---|---|



- ½
IRIS
- | | | | |
|-----------|-------------|---|---|
| 08.353.11 | 11,5 cm 4½" | ⌋ | ▲ |
|-----------|-------------|---|---|

ZAHNFLEISCHSCHEREN
 GUM SCISSORS
 CISEAUX À GENÇIVES
 TIJERAS PARA ENCÍAS
 FORBICI PER GENÇIVES



- ½
DEAN
- | | | | | |
|-----------|-----------|---|---|---|
| 08.317.17 | 17 cm 6¾" | S | ⌋ | ▲ |
|-----------|-----------|---|---|---|



- ½
DEAN
- | | | | | |
|-----------|-----------|---|---|---|
| 08.425.17 | 17 cm 6¾" | S | ▲ | ⌋ |
|-----------|-----------|---|---|---|



- ½
DEAN
- | | | | | |
|-----------|-----------|---|---|---|
| 08.427.17 | 17 cm 6¾" | S | ⌋ | ▲ |
|-----------|-----------|---|---|---|



- ½
LOCKLIN
- | | | | | | |
|-----------|-----------|---|---|---|---|
| 08.315.16 | 16 cm 6¼" | ⌋ | ⌋ | ▲ | I |
|-----------|-----------|---|---|---|---|



- ½
LOCKLIN
- | | | | | | | |
|-----------|-----------|---|---|---|---|---|
| 08.317.16 | 16 cm 6¼" | S | ⌋ | ⌋ | ▲ | I |
|-----------|-----------|---|---|---|---|---|

ZAHNFLEISCHSCHEREN

GUM SCISSORS
CISEAUX À GENCIVES
TIJERAS PARA ENCÍAS
FORBICI PER GENGIVE



½
GOLDMAN-FOX
08.820.13 13 cm5"



½
GOLDMAN-FOX
08.821.13 13 cm5"



½
GOLDMAN-FOX
08.822.13 13 cm5"



½
GOLDMAN-FOX
08.823.13 13 cm5"



½
WAGNER
08.824.12 12 cm4¾"



½
WAGNER
08.825.12 12 cm4¾"

LIGATURSCHEREN
LIGATURE SCISSORS
CISEAUX À LIGATURE
TIJERAS PARA LIGADURA
FORBICI PER LEGATURA



½
SPENCER
08.802.09 9 cm3½"

08.802.11 11 cm4¾"

08.802.12 12 cm4¾"



½
SHORTBENT
08.803.09 9 cm3½"



½
NORTHBENT
08.803.13 13 cm5"



½
LITTAUER
08.804.14 14 cm5½"

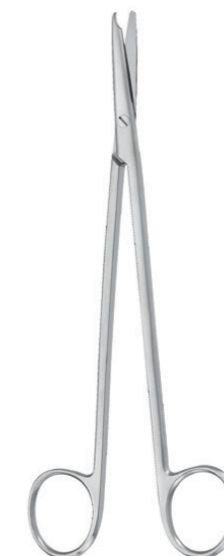

½
BUCK
08.806.14 14,5 cm5¾"



08.806.18 18 cm7"





½
EISELSBERG
08.810.12 12 cm4¾"





1/2
UNIVERSAL
08.831.12 12 cm|4 3/4"  





1/2
UNIVERSAL
08.835.12 12 cm|4 3/4"   





1/2
BEEBEE
08.850.10 10,5 cm|4"  





1/2
BEEBEE
08.851.10 10,5 cm|4"  





1/2
BEEBEE
08.853.10 10,5 cm|4"  









1/2
BEEBEE
08.854.12 12 cm|4 3/4"   



1/2
BEEBEE
08.855.12 12 cm|4 3/4"   





























Rundgriff
round handle
manche rond
mango redondo
manico rotondo
Schneide 10 mm
cutting edge 10 mm
lame 10 mm
hoja 10 mm
lama 10 mm

- | | | |
|-----------|--------------|---|
| 09.710.15 | 15 cm 6" |  |
| 09.711.15 | 15 cm 6" |  |
| 09.720.15 | 15 cm 6" |    |
| 09.721.15 | 15 cm 6" |    |
| 09.710.18 | 18 cm 7" |  |
| 09.711.18 | 18 cm 7" |  |
| 09.720.18 | 18 cm 7" |    |
| 09.721.18 | 18 cm 7" |    |
| 09.710.21 | 21 cm 8 1/4" |  |
| 09.711.21 | 21 cm 8 1/4" |  |
| 09.720.21 | 21 cm 8 1/4" |    |
| 09.721.21 | 21 cm 8 1/4" |    |
| 09.710.23 | 23 cm 9" |  |
| 09.711.23 | 23 cm 9" |  |



Flachgriff
flat handle
manche plat
mango plano
manico piatto
Schneide 10 mm
cutting edge 10 mm
lame 10 mm
hoja 10 mm
lama 10 mm

- | | | |
|-----------|--------------|---|
| 09.712.15 | 15 cm 6" |  |
| 09.713.15 | 15 cm 6" |  |
| 09.722.15 | 15 cm 6" |    |
| 09.723.15 | 15 cm 6" |    |
| 09.712.18 | 18 cm 7" |  |
| 09.713.18 | 18 cm 7" |  |
| 09.722.18 | 18 cm 7" |    |
| 09.723.18 | 18 cm 7" |    |
| 09.712.21 | 21 cm 8 1/4" |  |
| 09.713.21 | 21 cm 8 1/4" |  |
| 09.722.21 | 21 cm 8 1/4" |    |
| 09.723.21 | 21 cm 8 1/4" |    |
| 09.712.23 | 23 cm 9" |  |
| 09.713.23 | 23 cm 9" |  |



1/1

LISTER

08.901.11	11 cm 4 1/4"	
08.901.14	14 cm 5 1/2"	
08.901.16	16 cm 6 1/4"	
08.901.18	18 cm 7"	
08.901.20	20 cm 8"	



1/2

UNIVERSAL

08.950.15	15 cm 6"		
08.950.15B	15 cm 6"		
08.950.15G	15 cm 6"		
08.950.15R	15 cm 6"		
08.950.15Y	15 cm 6"		
08.950.15W	15 cm 6"		
08.950.18	18 cm 7"		
08.950.18B	18 cm 7"		
08.950.18G	18 cm 7"		
08.950.18R	18 cm 7"		
08.950.18Y	18 cm 7"		
08.950.18W	18 cm 7"		

04

PINZETTEN

- FORCEPS
- PINCES
- PINZAS
- PINZE





½
ADSON
10.170.12 12 cm|4¾"



½
ADSON
10.174.12 12 cm|4¾" 0,5



½
ADSON
10.180.12 12 cm|4¾" 1:2



½
ADSON micro
10.176.12 12 cm|4¾" I



½
ADSON micro
10.186.12 12 cm|4¾" 1:2 I



½
ADSON micro
10.173.12 12 cm|4¾" 0,4 1:2 I



½
10.102.13 13 cm|5"
10.102.14 14,5 cm|5¾"



½
10.110.13 13 cm|5" I
10.110.14 14,5 cm|5¾" I



½
10.114.14 14,5 cm|5¾" 0,5 I



½
10.120.13 13 cm|5" 1:2
10.120.14 14,5 cm|5¾" 1:2



½
10.130.13 13 cm|5" 1:2 I
10.130.14 14,5 cm|5¾" 1:2 I



½
CUSHING
10.220.17 17 cm 6¾"



½
CUSHING
10.230.17 17 cm 6¾"  1:2



½
CUSHING
10.224.17 17 cm 6¾" 0,5 



½
SEMKEN
10.260.12 12,5 cm 5"
10.260.15 15,5 cm 6"



½
SEMKEN
10.270.12 12,5 cm 5"
10.270.15 15,5 cm 6"  1:2



½
GILLIES
10.272.15 15,5 cm 6"  1:2



½
TAYLOR
10.274.17 17 cm 6¾"



½
TAYLOR
10.276.17 17,5 cm 7"  1:2



½
BROPHY
10.290.20 20 cm 8"  1:2





½
BROPHY
10.288.20 20 cm 8"



½
GERALD
10.302.18 18 cm 7" 



½
GERALD
10.310.18 18 cm 7"  1:2 

PINZETTEN
DISSECTING AND TISSUE FORCEPS
PINCES À DISSECTION
PINZAS DE DISECCIÓN
PINZE PER DISSEZIONE

Uhrmacherpinzette
watchmaker forcep
pince d'horloger
pinza de relojero
pinze da orologiaio



½
10.330.12 12 cm 4¾"

Nahtpinzetten
suturing forceps
pinces à sutures
pinzas para suturas
pinze per legature



½
10.346.15 15 cm 6"



½
10.348.15 15 cm 6"



½
10.349.15 15 cm 6"

Splitterzangen
splinter forceps
pinces à échardes
pinzas para espinas
pinze per scheggie



½
PEET
10.821.11 11,5 cm 4¼"



½
STIEGLITZ
10.822.13 13,5 cm 5¼"



½
STIEGLITZ
10.823.13 13,5 cm 5¼" 45°
10.823.90 13,5 cm 5¼" 90°



½
VIRTUS (RALK)
10.828.15 15 cm 6"

ATRAUMISCHE PINZETTEN
ATRAUMATIC TISSUE FORCEPS
PINCES ATRAUMATIQUES
PINZAS ATRAUMÁTICAS
PINZE ATRAUMATICHE



½
DE BAKAY
11.304.16 16 cm 6¼" 3
11.304.20 20 cm 8" 3
11.306.16 16 cm 6¼" 1
11.306.20 20 cm 8" 1
11.308.16 16 cm 6¼" 2
11.308.20 20 cm 8" 2
11.334.15 15 cm 6" 4



½
DE BAKAY
11.309.16 16 cm 6¼" 5
11.309.20 20 cm 8" 5

passend für
for
allant avec
para
per

LONDON-COLLEGE

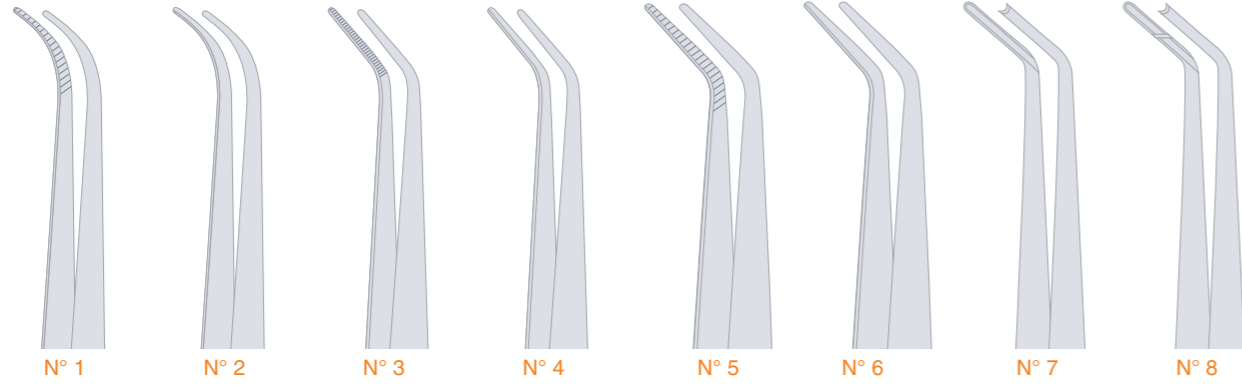

1/1

LONDON-COLLEGE

83.029.01	15 cml6"	N° 1		
83.029.03	15 cml6"	N° 3		
83.029.05	15 cml6"	N° 5		

1/1

LONDON-COLLEGE

83.031.01	15 cml6"	N° 1	
83.031.02	15 cml6"	N° 2	
83.031.03	15 cml6"	N° 3	
83.031.04	15 cml6"	N° 4	
83.031.05	15 cml6"	N° 5	
83.031.06	15 cml6"	N° 6	
83.031.07	15 cml6"	N° 7	
83.031.08	15 cml6"	N° 8	

1/1

LONDON-COLLEGE

83.033.01	15 cml6"	N° 1	
83.033.02	15 cml6"	N° 2	
83.033.03	15 cml6"	N° 3	
83.033.04	15 cml6"	N° 4	
83.033.05	15 cml6"	N° 5	
83.033.06	15 cml6"	N° 6	
83.033.07	15 cml6"	N° 7	
83.033.08	15 cml6"	N° 8	

passend für
for
allant avec
para
per

MERIAM

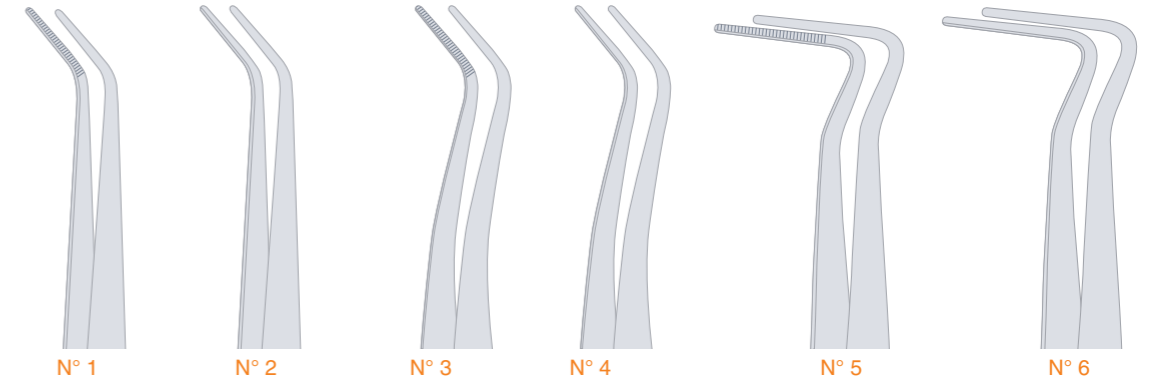

1/1

LONDON-COLLEGE

83.037.01	15 cml6"	N° 1	
83.037.02	15 cml6"	N° 2	
83.037.03	15 cml6"	N° 3	
83.037.04	15 cml6"	N° 4	
83.037.05	15 cml6"	N° 5	
83.037.06	15 cml6"	N° 6	
83.037.07	15 cml6"	N° 7	
83.037.08	15 cml6"	N° 8	

1/1

MERIAM

83.099.01	16 cml6¼"	N° 1	
83.099.03	16 cml6¼"	N° 3	
83.099.05	16 cml6¼"	N° 5	

1/1

MERIAM

83.101.01	16 cml6¼"	N° 1	
83.101.02	16 cml6¼"	N° 2	
83.101.03	16 cml6¼"	N° 3	
83.101.04	16 cml6¼"	N° 4	
83.101.05	16 cml6¼"	N° 5	
83.101.06	16 cml6¼"	N° 6	

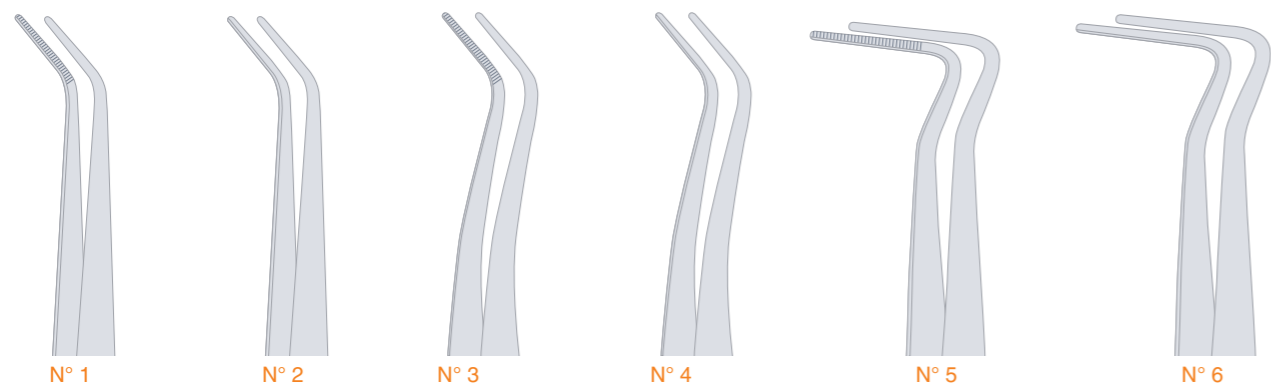

MERIAM

83.103.01	16 cm 6 1/4"	N° 1	Y
83.103.02	16 cm 6 1/4"	N° 2	
83.103.03	16 cm 6 1/4"	N° 3	
83.103.04	16 cm 6 1/4"	N° 4	
83.103.05	16 cm 6 1/4"	N° 5	
83.103.06	16 cm 6 1/4"	N° 6	

FLAGG

83.107.01	16 cm 6 1/4"	N° 1	Y
83.107.02	16 cm 6 1/4"	N° 2	
83.107.03	16 cm 6 1/4"	N° 3	
83.107.04	16 cm 6 1/4"	N° 4	

FLAGG

83.109.01	16 cm 6 1/4"	N° 1	Y
83.109.02	16 cm 6 1/4"	N° 2	
83.109.03	16 cm 6 1/4"	N° 3	
83.109.04	16 cm 6 1/4"	N° 4	



LANDGRAF

83.115.03	15 cm 6"	1	Y
83.115.04	15 cm 6"	2	

PERRY

83.120.12	12,5 cm 5"		
-----------	------------	--	--

PERRY

83.121.12	12,5 cm 5"		C
-----------	------------	--	---



ZAHNPINZETTEN
DENTAL TWEEZERS
PRÉCELLES POUR COTON
PINZAS DENTAL
PINZE DENTALE



1/1
MERIAM USA
83.133.17 17 cm 6 3/4"



1/1
LONDON-COLLEGE modified
83.141.15 15 cm 6"



1/1
CRANE-KAPLAN
83.343.01 15 cm 6" 1
83.343.02 15 cm 6" 2

Markierpinzetten
pocket markers
pinces pour marquer
pinzas para marcar
pinze per marcare

05

ARTERIENKLEMMEN
HEMOSTATIC FORCEPS
PINCES HÉMOSTATIQUES
PINZAS HEMOSTÁTICAS
PINZE EMOSTATICHE

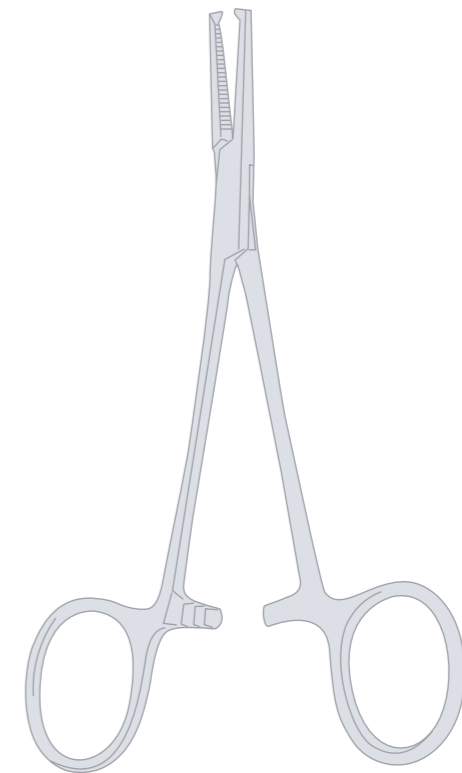



½
HALSTED-MOSQUITO
12.220.12 12,5 cm5" 





½
HALSTED-MOSQUITO
12.221.12 12,5 cm5" 



½
HALSTED-MOSQUITO
12.230.12 12,5 cm5"   1:2



½
HALSTED-MOSQUITO
12.231.12 12,5 cm5"   1:2



½
KELLY
12.240.14 14 cm5½" 



½
KELLY
12.241.14 14 cm5½" 



½
KELLY-RANKIN
12.242.16 16 cm6¼" 



½
KELLY-RANKIN
12.243.16 16 cm6¼" 



½
CRILE
12.250.14 14 cm5½" 



½
CRILE
12.251.14 14 cm5½" 





½
PROVIDENCE-HOSPITAL
12.270.14 14 cm|5½"



½
PROVIDENCE-HOSPITAL
12.271.14 14 cm|5½"



½
PEAN
12.368.14 14 cm|5½"



½
ROCHESTER-OGHSNER
12.320.14 14 cm|5½" 1:2



½
ROCHESTER-OGHSNER
12.321.14 14 cm|5½" 1:2



½
ROCHESTER-PEAN
12.310.14 14 cm|5½"



½
ROCHESTER-PEAN
12.311.14 14 cm|5½"

Tuchklemmen
towel clamps
pinces à champs
pinzas de campo
pinze di campo



½
SCHAEDEL
14.101.09 9 cm|3½"



½
BACKHAUS
14.111.09 9 cm|3½"
14.111.11 11 cm|4¼"



½
14.123.11 11 cm|4¼"
14.123.13 13 cm|5"
14.123.14 14 cm|5½"



GEWEBEFASSZANGEN
TISSUE GRASPING FORCEPS
PINCES À TISSUS
PINZAS PARA TEJIDOS
PINZE PER TESSUTI

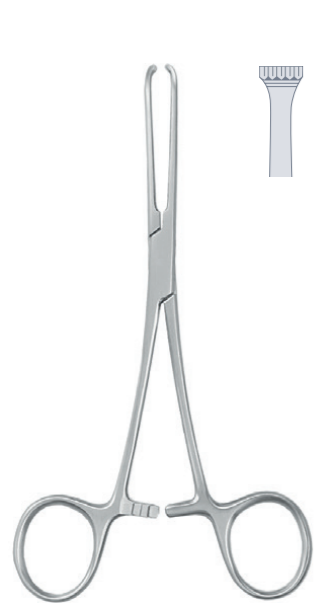

½

ALLIS-BABY

64.102.14 14 cm 5½"



4:5



½

ALLIS

64.110.15 15 cm 6"



4:5

64.120.15 15 cm 6"



5:6

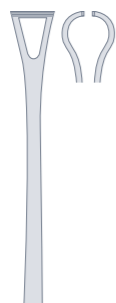

½

BABCOCK

64.160.16 16 cm 6¼"



½

BABCOCK

64.164.16 16 cm 6¼"

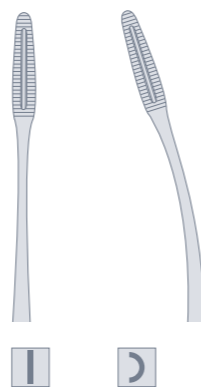

½

GROSS-MAIER

16.110.20 20 cm 8"



16.111.20 20 cm 8"



06

WUNDHAKEN
RETRACTORS
ÉCARTEURS
SEPARADORES
DIVARICATORI



N° 1 = 26 x 10 mm
N° 2 = 30 x 10 mm

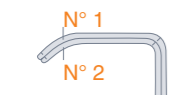

N° 1 = 30 x 13 mm
N° 2 = 34 x 13 mm



½

FARABEUF

18.102.12 12 cm | 5 ¾"

½

ROUX

18.120.00 set N° 1-3

18.120.14 14 cm | 5 ½" 24 x 20 mm | 30 x 28 mm N° 1

18.120.15 15 cm | 6" 29 x 26 mm | 36 x 36 mm N° 2

18.120.17 17 cm | 6 ¾" 33 x 29 mm | 38 x 43 mm N° 3

18.120.18 18 cm | 7" 29 x 24 mm | 45 x 28 mm N° 4

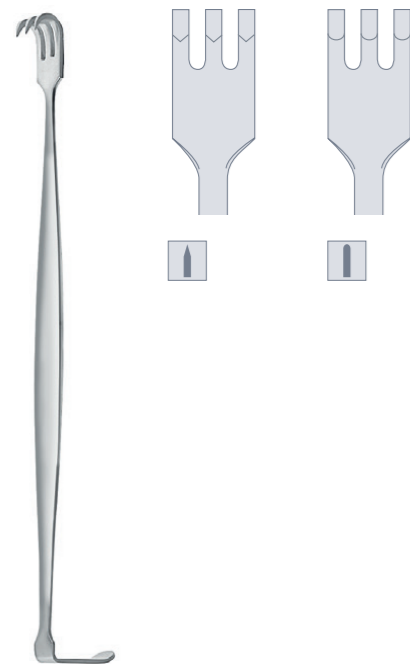

½

SENN

18.160.17 17 cm | 6 ¾"

18.161.17 17 cm | 6 ¾"

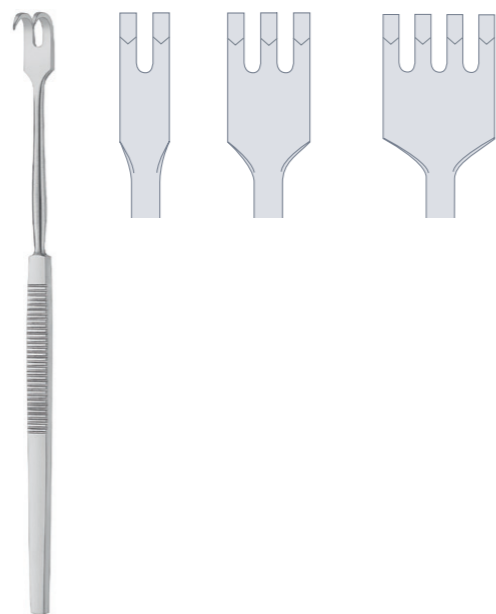

½

18.220.02 16 cm | 6 ¼"

18.220.03 16 cm | 6 ¼"

18.220.04 16 cm | 6 ¼"

Nasenflügelhäkchen
alar hooklet
crochet pour ailes de nez
ganchito para alas de nariz
uncino per le pinne nasali

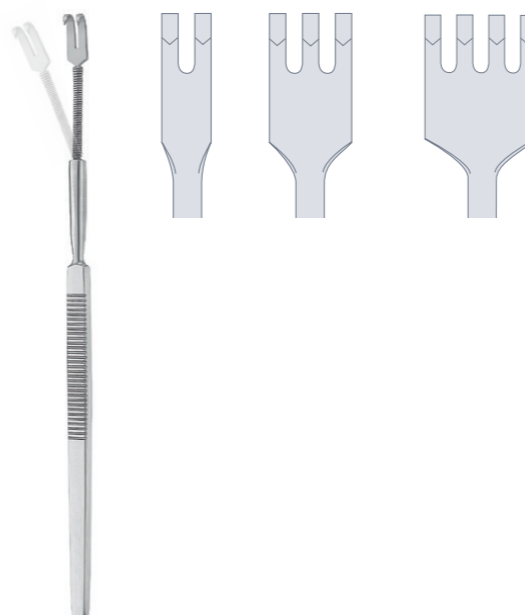

½

18.226.02 16 cm | 6 ¼"

18.226.03 16 cm | 6 ¼"

18.226.04 16 cm | 6 ¼"



½

GILLIES

46.560.18 18 cm | 7"



½

GILLIES

46.562.18 18 cm | 7"

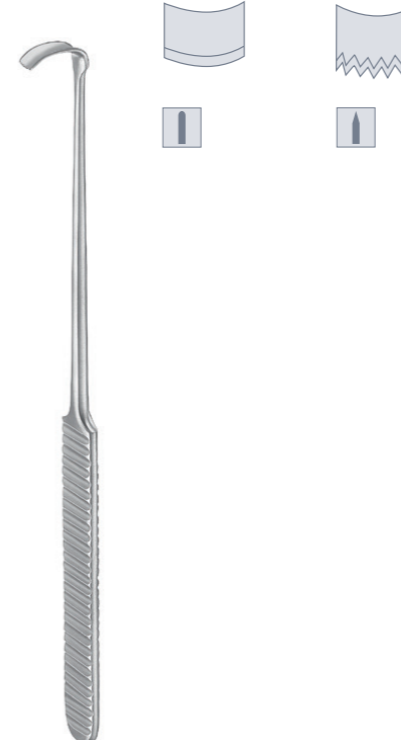

½

STRANDELL-STILLE

18.228.08 19 cm | 7 ½"

18.228.09 19 cm | 7 ½"



½

VOLKMANN

18.281.03 21,5 cm | 8 ½"



½

VOLKMANN

18.281.04 21,5 cm | 8 ½"

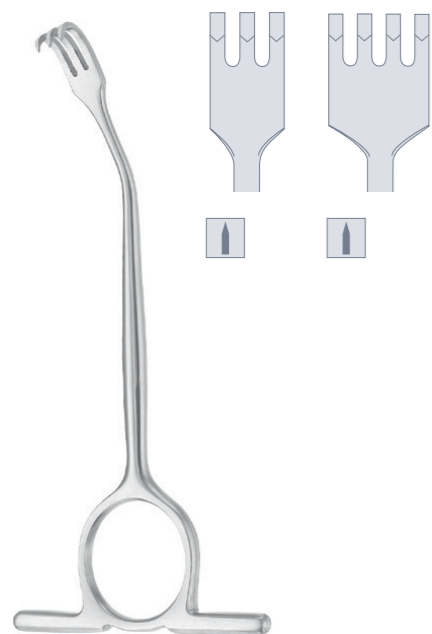

½

WILLIGER

18.250.03 12,5 cm 5"

18.250.04 12,5 cm 5"

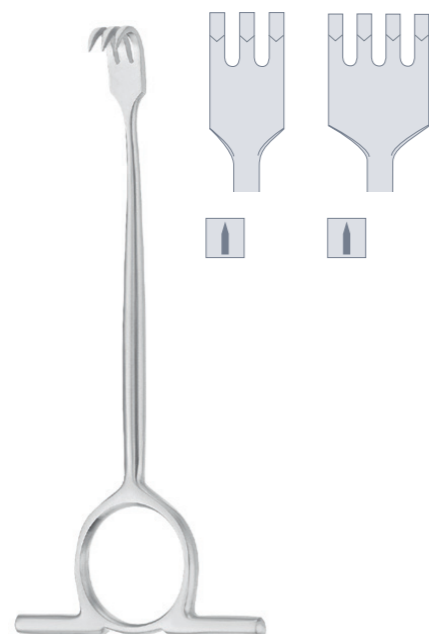

½

WILLIGER

18.252.03 12,5 cm 5"

18.252.04 12,5 cm 5"

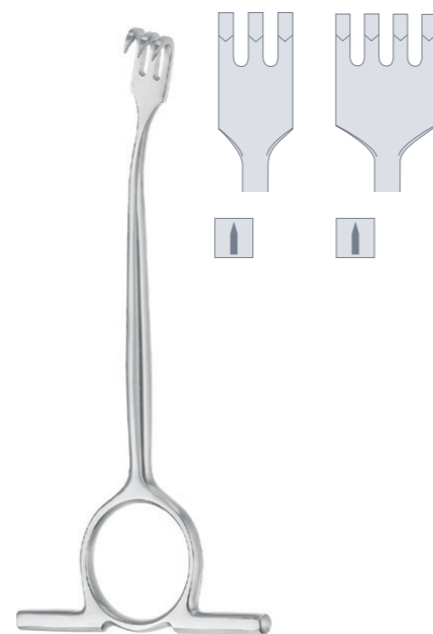

½

WILLIGER

18.254.03 12,5 cm 5"

18.254.04 12,5 cm 5"



½

LANGENBECK

18.310.01 22 cm 8¾" 30 x 11 mm N° 1

18.310.02 22 cm 8¾" 30 x 14 mm N° 2

18.310.03 22 cm 8¾" 30 x 16 mm N° 3

18.310.04 22 cm 8¾" 40 x 11 mm N° 4

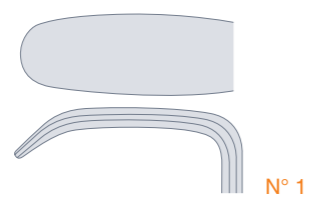

N° 1

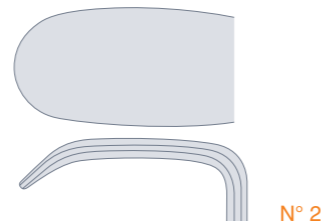

N° 2

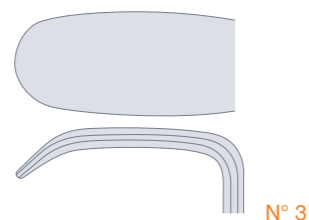

N° 3

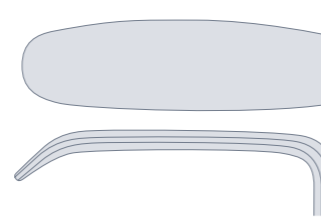

N° 4



½

KOCHER-LANGENBECK

18.342.05 22 cm 8¾" 40 x 11 mm N° 1

18.342.06 22 cm 8¾" 55 x 11 mm N° 2

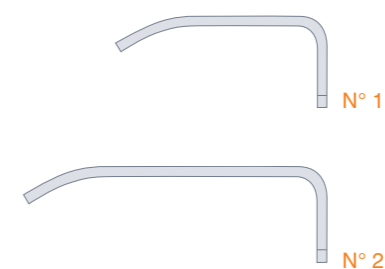

N° 1

N° 2



½

GREEN

18.348.22 22,5 cm 8¾" 22 x 22 mm



½

KOCHER-LANGENBECK

18.354.21 21 cm 8¼" 23 x 8 mm



½

MIDDELDORFF

18.344.14 21,5 cm 8½" 14 x 17 mm N° 1

18.344.20 22 cm 8¾" 20 x 22 mm N° 2

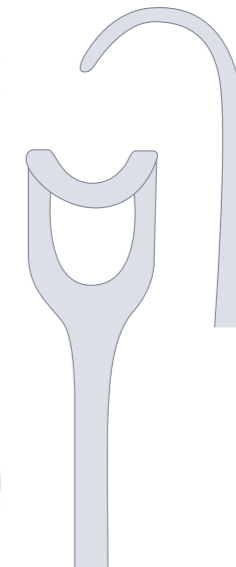

N° 1

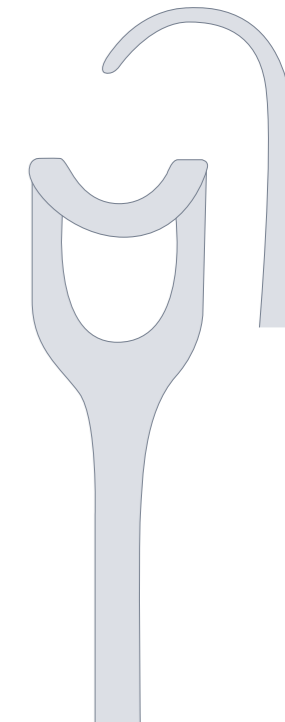

N° 2



Kinnhalter
chin retractor
écarteur pour menton
separador para mentón
divaricatore per il mento

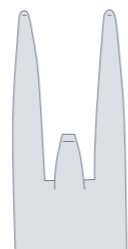

- ½
OBWEGESER
- 48.599.30 30 x 912 mm
 - 48.599.45 45 x 912 mm
 - 48.599.60 60 x 912 mm

- ½
OBWEGESER
- 48.601.16 16 cml6¼"

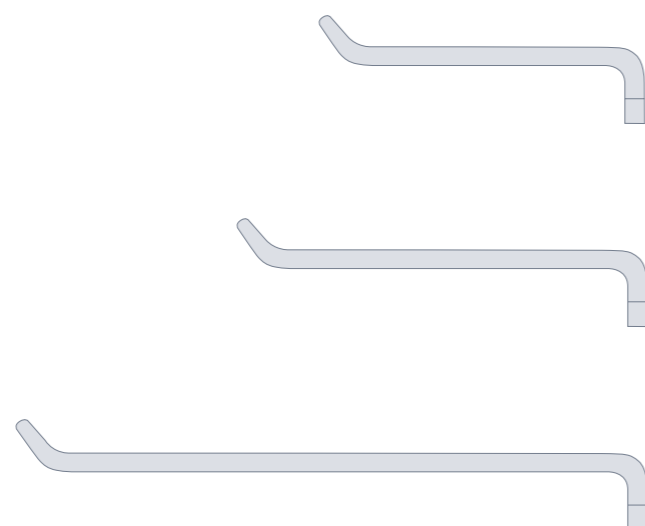
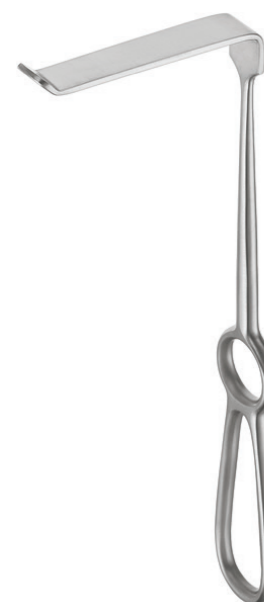

- ½
OBWEGESER
- 48.593.40 11 x 40 mm
 - 48.593.55 11 x 55 mm
 - 48.593.80 16 x 80 mm



- ½
WARD
- 48.590.15 15,5 cml6"



- ½
BOWDLER-HENRY
- 48.590.70 16 cml6¼"



- ½
KAY (AUSTIN)
- 48.590.73 80 mm

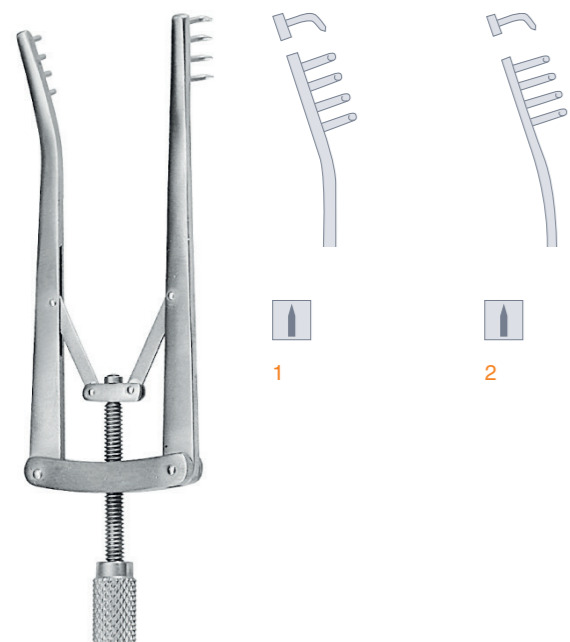

½

ALM

18.620.07	7 cm 2¾"	1	
18.620.10	10 cm 4"	2	

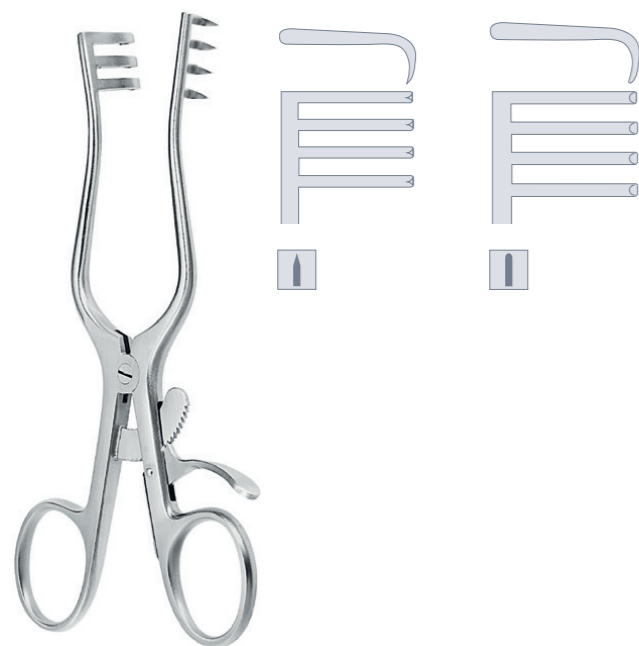

½

WEITLANER

18.670.14	13 cm 5"		
18.671.14	13 cm 5"		

07

■ NADELHALTER
 NEEDLE HOLDERS
 PORTE-AIGUILLES
 PORTA-AGUJAS
 PORT'AGHI

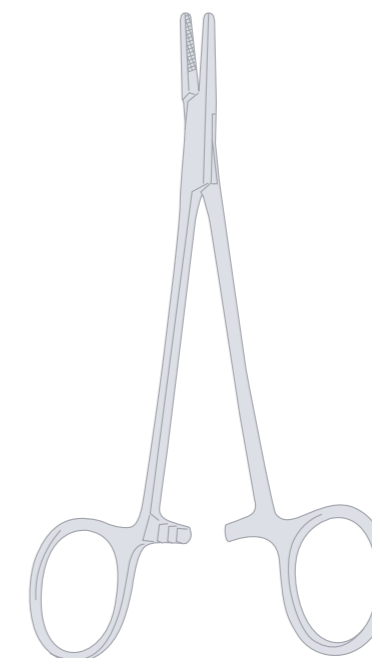



½
HALSEY
24.130.13 13 cm|5" 1
24.140.13 13 cm|5" 2

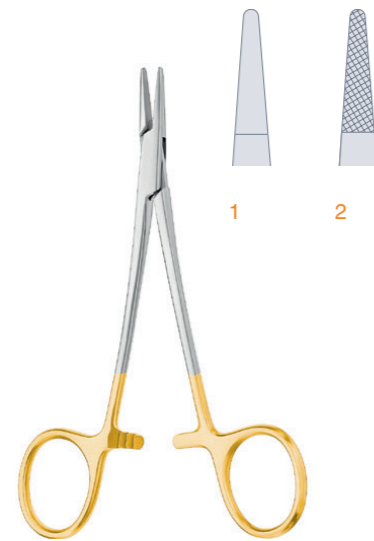

½
HALSEY
24.134.13 13 cm|5" 1 0,4
24.144.13 13 cm|5" 2 0,4



½
BAUMGARTNER
24.150.12 12,5 cm|5"
24.150.14 14 cm|5½"



½
BAUMGARTNER
24.154.12 12,5 cm|5" 0,5
24.154.14 14 cm|5½" 0,5



½
CRILE-WOOD
24.160.15 15 cm|6"



½
CRILE-WOOD
24.164.15 15 cm|6" 0,4



½
CRILE-MURRAY
24.170.15 15 cm|6" I



½
CRILE-MURRAY
24.174.15 15 cm|6" 0,4
I



½
MAYO-HEGAR
24.180.16 16 cm|6¼"
24.180.18 18 cm|7"



½
MAYO-HEGAR
24.184.16 16 cm|6¼" 0,5
24.184.18 18 cm|7" 0,5



½
MAYO-HEGAR
24.194.18 18 cm|7" 0,4
I



½
DE BAKEY
24.214.18 18 cm|7" 0,4





½

RYDER

24.224.15 15 cm|6" 0,4

24.224.18 18 cm|7" 0,4



½

RYDER Vascular

24.226.15 15,5 cm|6" 0,3

24.226.18 18 cm|7" 0,3



½

24.280.14 14 cm|5½" 0,3

24.280.18 18 cm|7" 0,3



½

TOENNIS

24.360.18 18 cm|7"



½

TOENNIS

24.364.18 18 cm|7" 0,5



½

MATHIEU

24.386.20 20 cm|8" 0,5



½

MATHIEU

24.370.14 14 cm|5½"

24.370.17 17 cm|6¾"



½

MATHIEU

24.374.14 14 cm|5½" 0,5

24.374.17 17 cm|6¾" 0,5



½

MATHIEU

24.390.14 14 cm|5½" I

24.390.17 17 cm|6¾" I



½

MATHIEU

24.394.14 14 cm|5½" 0,5

24.394.17 17 cm|6¾" 0,5



½

OLSEN-HEGAR

24.410.14 14 cm|5½"

24.410.18 18 cm|7"



½

OLSEN-HEGAR

24.414.14 14 cm|5½" 0,5

24.414.18 18 cm|7" 0,5

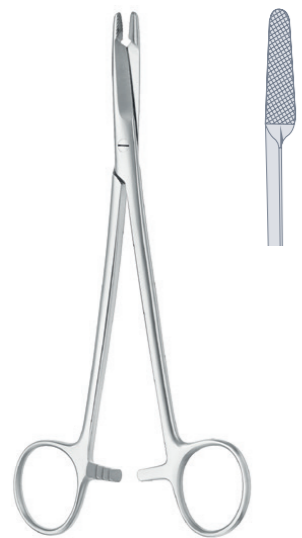

1/2
OLSEN-HEGAR
24.420.17 17 cm 6 3/4"



1/2
OLSEN-HEGAR
24.424.17 17 cm 6 3/4" 0,5



1/2
STEVENS
24.612.13 13 cm 5"
24.612.15 15 cm 6"



1/2
GILLES
24.430.16 16 cm 6 1/4"



1/2
GILLES
24.434.16 16 cm 6 1/4" 0,5



1/2
ARRUGA
24.620.16 16 cm 6 1/4"



1/2
ARRUGA
24.624.16 16 cm 6 1/4" 0,4



1/4
CASTROVIEJO
24.670.14 14 cm 5 1/2"

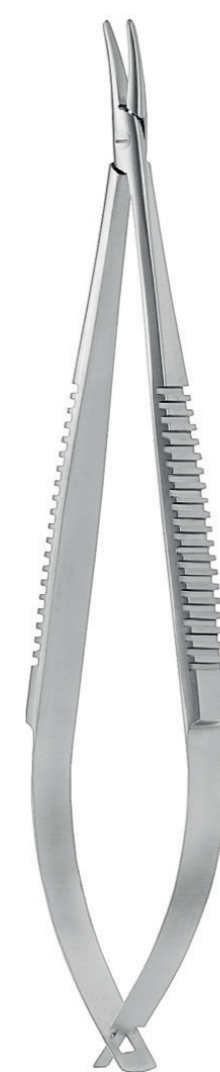

1/4
CASTROVIEJO
24.677.14 14 cm 5 1/2"









1/4
CASTROVIEJO
24.679.14 17 cm 6 3/4" 0,3



MIKRO-NADELHALTER
 MICRO NEEDLE HOLDERS
 PORTE-AIGUILLES, MICRO
 PORTA-AGUJAS, MICRO
 PORT'AGHI, MICRO



1/1
 24.778.14 14 cm 5 1/2" 0,3  

1/1
 24.920.15 15 cm 6"    

08

ORTHOPÄDIE
 ORTHOPAEDICS
 ORTHOPÉDIE
 ORTOPEDIA
 ORTOPEDIA

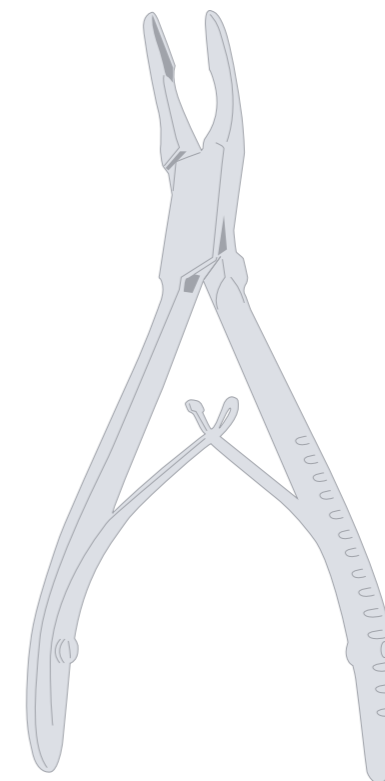



½
FRIEDMAN-MINI
32.101.12 12 cm 4¾"



½
FRIEDMAN
32.101.14 14 cm 5½"



½
FRIEDMAN
32.102.14 14 cm 5½"



½
FRIEDMAN
32.102.15 15 cm 6"



½
CLEVELAND
32.103.14 14 cm 5½"



½
CLEVELAND
32.105.17 17 cm 6¾"



½
CLEVELAND
32.106.15 15 cm 6"



½
MEAD
32.107.16 16 cm 6¼"



½
MEAD
32.109.16 16,5 cm 6½"

Knochensplitterzange
bone cutting forcep
pince coupante à os
pinzas cortante para hueso
cesoie per ossa



½
BLUMENTHAL
32.115.15 15,5 cm 6" 30° 1
32.117.15 15,5 cm 6" 45° 2
32.119.15 15,5 cm 6" 90° 3



½
LUER
32.131.15 15 cm 6" 1
32.133.15 15 cm 6" 2



½

BEYER

32.201.18 18 cm 7"



½

BOEHLER

32.210.15	15 cm 6"	1
32.213.15	15 cm 6"	2

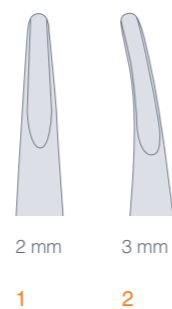

½

RUSKIN

32.216.18	18 cm 7"	1
32.217.18	18 cm 7"	2

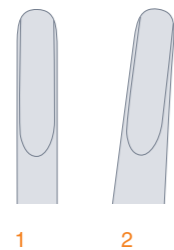

½

32.386.20 20 cm 8"



½

DINGMANN

32.407.19 19 cm 7½"



½

32.409.13 13,5 cm 5¼"



lange Sperre
long ratchet
cremaillère longue
cremallera larga
cremagliera lunga



½

ADSON

33.391.15 15 cm 6"



mit Bohrführung
with drill guide
avec guide de perçage
guía para perforación
con guida per trapano

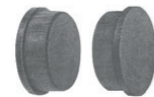

1/2

MEAD

32.696.32 17 cm 6 3/4" ø 27 mm 320 g

32.697.02

Ersatzbacken-Paar aus Kunststoff
 plastic replacement discs
 plaques de rechange en plastique
 tapas de repuesto de plástico
 disco di ricambio plastico

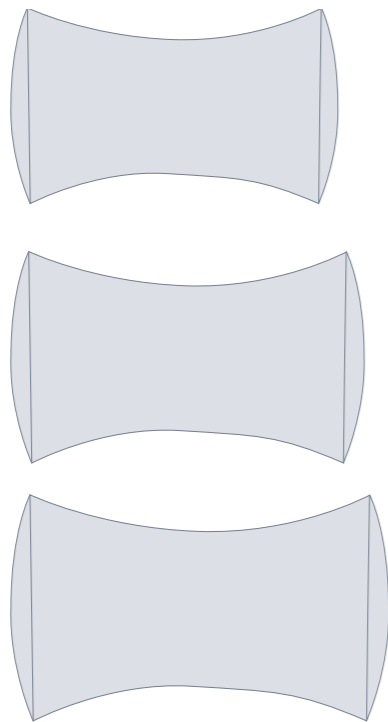

WILLIGER

32.694.30 24 cm 9 1/2" ø 26 mm 300 g

32.694.34 24 cm 9 1/2" ø 28 mm 340 g

32.694.40 24 cm 9 1/2" ø 30 mm 400 g

bleigefüllt
 lead filled
 rempli de plomb
 relleno de plomo
 ripieno di piombo



Nietherhammer mit breiter Pinne
 riveting hammer wide edge
 marteau à rivets avec large panne
 martillo para remachar con peña ancha
 martello per ribadire a bordo largo

Hornhammer
 horn mallet
 marteau à corne
 martillo córneo
 martello a corno



1/2

87.102.21 21,5 cm 8 1/2"



1/2

87.110.24 25 cm 10"



1/2

87.114.21 21,5 cm 8 1/2"



N° 0



N° 1



N° 2



N° 3



N° 5

½

VOLKMANN

32.470.00	17 cm 6¾"	N° 0	oval, mit Hohlheft
32.470.01	17 cm 6¾"	N° 1	oval, with hollow handle
32.470.02	17 cm 6¾"	N° 2	ovale, avec manche creux
32.470.03	17 cm 6¾"	N° 3	ovalada, con mango hueco
32.470.05	17 cm 6¾"	N° 5	ovale, con manico vuoto



N° 0010



N° 011



N° 112

½

WILLIGER

32.496.00	13,5 cm 5¼"	N° 0010
32.496.01	13,5 cm 5¼"	N° 011
32.496.12	13,5 cm 5¼"	N° 112



N° 0010



N° 011



N° 112

½

MARTINI

32.498.00	13,5 cm 5¼"	N° 0010
32.498.01	13,5 cm 5¼"	N° 011
32.498.12	13,5 cm 5¼"	N° 112



N° 00



N° 0



N° 1



N° 2



N° 00



N° 0



N° 1



N° 2



¼

WILLIGER

82.820.20	16,5 cm 6½"	N° 00
82.820.10	16,5 cm 6½"	N° 0
82.821.01	16,5 cm 6½"	N° 1
82.821.02	16,5 cm 6½"	N° 2



¼

WILLIGER

82.826.20	16,5 cm 6½"	N° 00
82.826.10	16,5 cm 6½"	N° 0
82.827.01	16,5 cm 6½"	N° 1
82.827.02	16,5 cm 6½"	N° 2



¼

WILLIGER

82.822.20	16,5 cm 6½"	N° 00
82.822.10	16,5 cm 6½"	N° 0
82.823.01	16,5 cm 6½"	N° 1
82.823.02	16,5 cm 6½"	N° 2



¼

WILLIGER

82.828.20	16,5 cm 6½"	N° 00
82.828.10	16,5 cm 6½"	N° 0
82.829.01	16,5 cm 6½"	N° 1
82.829.02	16,5 cm 6½"	N° 2



N° 0010 N° 010 N° 111



N° 0010 N° 010 N° 111



1/1

CHOMPRET

82.851.01 15 cm 6"



1/1

WILLIGER

82.859.00 16 cm 6 1/4" N° 0010
82.859.10 16 cm 6 1/4" N° 010
82.859.11 16 cm 6 1/4" N° 111



1/1

MARTINI

82.863.00 16 cm 6 1/4" N° 0010
82.863.10 16 cm 6 1/4" N° 010
82.863.11 16 cm 6 1/4" N° 111



1/1

HEMINGWAY

82.871.11 18 cm 7" N° 1R1L
82.871.22 18 cm 7" N° 2R1L
82.871.33 18 cm 7" N° 3R1L

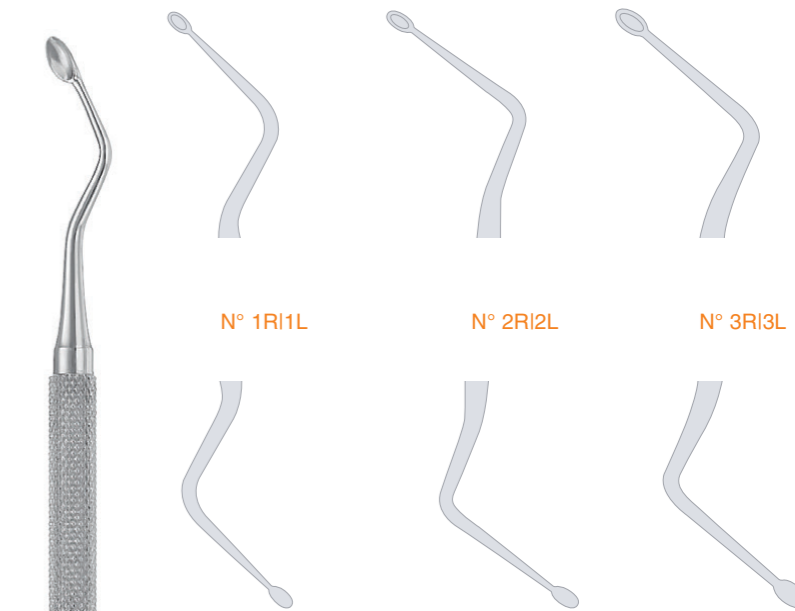

N° 1R1L

N° 2R1L

N° 3R1L

1/1

HEMINGWAY

82.871.11R 18 cm 7" N° 1R1L
82.871.22R 18 cm 7" N° 2R1L
82.871.33R 18 cm 7" N° 3R1L

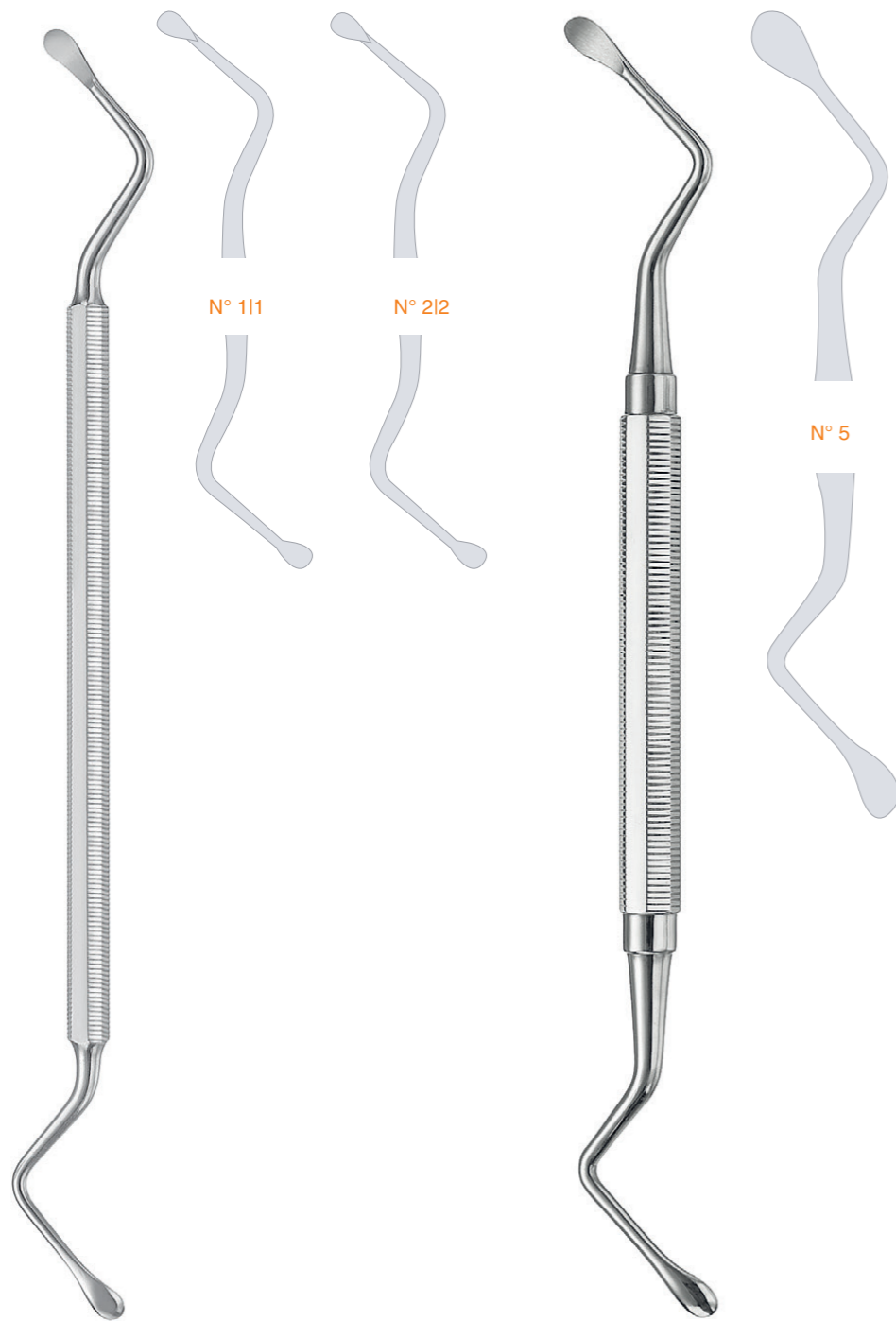

1/1
LUCAS
82.889.11 17 cm 6 3/4" N° 111
82.889.22 17 cm 6 3/4" N° 212

MEAD
82.890.05 17 cm 6 3/4" N° 5

MOLT
82.909.01 16 cm 6 1/4"



abwärts schneidend
downwards cutting
tranchant en bas
corte abajo
tagliente in basso

1/1
MILLER-COLBURN
82.895.01 18 cm 7" N° 1

1/1
MILLER-COLBURN
82.895.02 18 cm 7" N° 2

1/1
MILLER-COLBURN
82.895.03 18 cm 7" N° 3



abwärts schneidend
downwards cutting
tranchant en bas
corte abajo
tagliente in basso



1/1
MILLER-COLBURN
82.895.04 18 cm 7" N° 4



1/1
MILLER-COLBURN
82.895.05 18 cm 7" N° 5



1/1
MILLER-COLBURN
82.896.01 18 cm 7" N° 1

Kreuzhieb
cross cut
coupe transversale
corte en cruz
tagliente a croce



1/1
SELDIN
82.906.12 18 cm 7" N° 12



1/1
WILLIGER
82.898.17 17 cm 6 3/4"



1/1
WILLIGER
82.899.16 16 cm 6 1/4"



1/1
FREER
46.415.18 18,5 cm 7 1/4"



1/1
FREER
46.419.19 19 cm 7 1/2"



1/1
SELDIN
 82.905.22 19 cm 7 1/2" N° 22



1/1
SELDIN
 82.905.23 19 cm 7 1/2" N° 23



1/1
OHL
 82.902.18 18 cm 7"



1/1
GOLDMAN-FOX
 82.921.14 18 cm 7"



1/1
WILLIGER
 32.713.13 13 cm 5"



1/1
WILLIGER
 32.713.16 16 cm 6 1/4"





1/4

MOLT

82.909.24 19 cm 7 1/2" N° 214



1/4

MOLT

82.910.09 19 cm 7 1/2" N° 9



1/4

WAKEFILED

82.931.01 17 cm 6 3/4" N° 1W

4 mm



1/4

FREER

46.450.04 16 cm 6 1/4"

4 mm



1/4

FREER

46.451.04 16 cm 6 1/4"

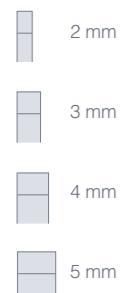
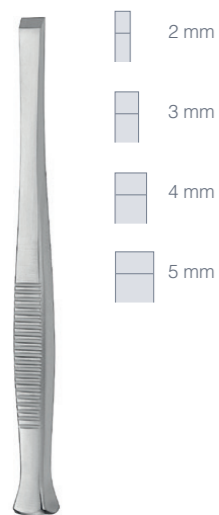

1/2

PARTSCH

32.620.02	13,5 cm 5 1/4"	2 mm
32.620.03	13,5 cm 5 1/4"	3 mm
32.620.04	13,5 cm 5 1/4"	4 mm
32.620.05	13,5 cm 5 1/4"	5 mm

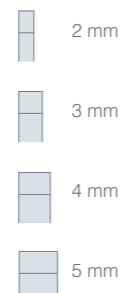

1/2

PARTSCH

32.622.02	17 cm 6 3/4"	2 mm
32.622.03	17 cm 6 3/4"	3 mm
32.622.04	17 cm 6 3/4"	4 mm
32.622.05	17 cm 6 3/4"	5 mm

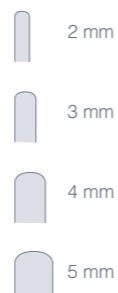

1/2

PARTSCH

32.623.02	13,5 cm 5 1/4"	2 mm
32.623.03	13,5 cm 5 1/4"	3 mm
32.623.04	13,5 cm 5 1/4"	4 mm
32.623.05	13,5 cm 5 1/4"	5 mm

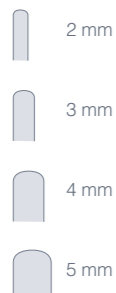

1/2

PARTSCH

32.625.02	17 cm 6 3/4"	2 mm
32.625.03	17 cm 6 3/4"	3 mm
32.625.04	17 cm 6 3/4"	4 mm
32.625.05	17 cm 6 3/4"	5 mm

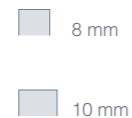

1/2

LEXER-MINI

32.664.08	18 cm 7"	8 mm
32.664.10	18 cm 7"	10 mm

09

■ **KNOPFSONDEN**

PROBES

SONDES BOUTONNÉES

SONDAS ABOTONADAS

SONDE A BOTTONE





½

20.104.11	11,5 cm 4½"	ø 1 mm
20.104.13	13 cm 5"	ø 1 mm
20.104.14	14,5 cm 5¾"	ø 1 mm

N°	00	0	1	2	3	4	5	6	7	8
ø mm	0,7	0,8	0,9	1,1	1,3	1,4	1,5	1,6	1,8	1,9



½

BOWMAN

42.616.00	13 cm 5"	N° 0010	Neusilber
42.616.01	13 cm 5"	N° 011	nickel silver
42.616.12	13 cm 5"	N° 112	maillechort
42.616.23	13 cm 5"	N° 213	alpaca
42.616.34	13 cm 5"	N° 314	argentone
42.616.45	13 cm 5"	N° 415	
42.616.56	13 cm 5"	N° 516	
42.616.67	13 cm 5"	N° 617	
42.616.78	13 cm 5"	N° 718	



½

BOWMAN

42.614.00	13 cm 5"	N° 0010	Neusilber
42.614.01	13 cm 5"	N° 011	nickel silver
42.614.12	13 cm 5"	N° 112	maillechort
42.614.23	13 cm 5"	N° 213	alpaca
42.614.34	13 cm 5"	N° 314	argentone
42.614.45	13 cm 5"	N° 415	
42.614.56	13 cm 5"	N° 516	
42.614.67	13 cm 5"	N° 617	
42.614.78	13 cm 5"	N° 718	

10

■ MUND UND ZUNGE
 MOUTH AND TONGUE
 BOUCHE ET LANGUE
 BOCA Y LENGUA
 BOCCA E LINGUA





Holz, Packung 100 Stück
wood, package 100 pieces
bois, boîte 100 pièces
madera, paquete 100 piezas
legno, confezione 100 pezzi

½

48.102.16 16 cm 6¼"



½

FRENZEL

48.105.16 16,5 cm 6½"



½

BRUENINGS

48.107.19 19 cm 7½"



½

BUCHWALD

48.109.19 19 cm 7½"



½

HARTMANN

48.111.15 15 cm 6"



½

WIEDER

48.115.01 14 cm 5½" 36 mm
48.115.02 15 cm 6" 43 mm

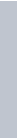

½

TOBOLD

48.119.14 14,5 cm 5¾"



½

TOBOLD

48.119.15 15 cm 6"



½

DOYEN

48.112.13 13,5 cm 5¼"
48.112.16 16 cm 6¼"



24 | 30 mm



30 | 34 mm



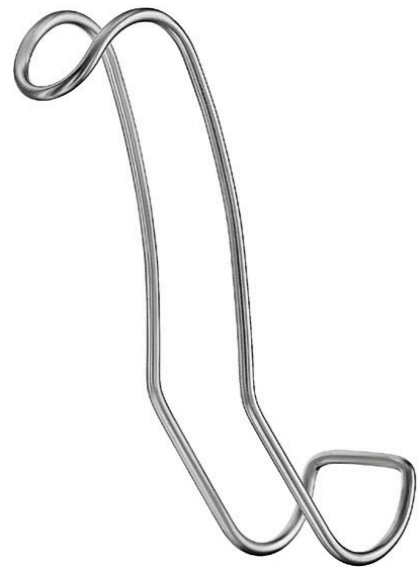

½
STERNBERG
 48.229.14 14 cml5½"



½
SIMPLEX
 48.230.11 11 cml4¼"



½
CAWOOD-MINNESOTA
 48.233.15 15 cml6"



½
CAWOOD-MINNESOTA
 48.233.14KL 14 cml5½"



½
DOYEN-JANSEN (MOLT)
 48.265.12 12 cml4¾"
 48.265.14 14 cml5½"



½
DENHARDT
 48.267.12 12 cml4¾"



½
ROSER-KOENIG
 48.270.16 16 cml6¼"
 48.270.19 19 cml7½"



½
HEISTER
 48.272.13 13 cml5"



½
JENNINGS
 48.274.09 9 cml3½"
 48.274.11 11 cml4¼"
 48.274.13 13 cml5"
 48.274.15 15 cml6"

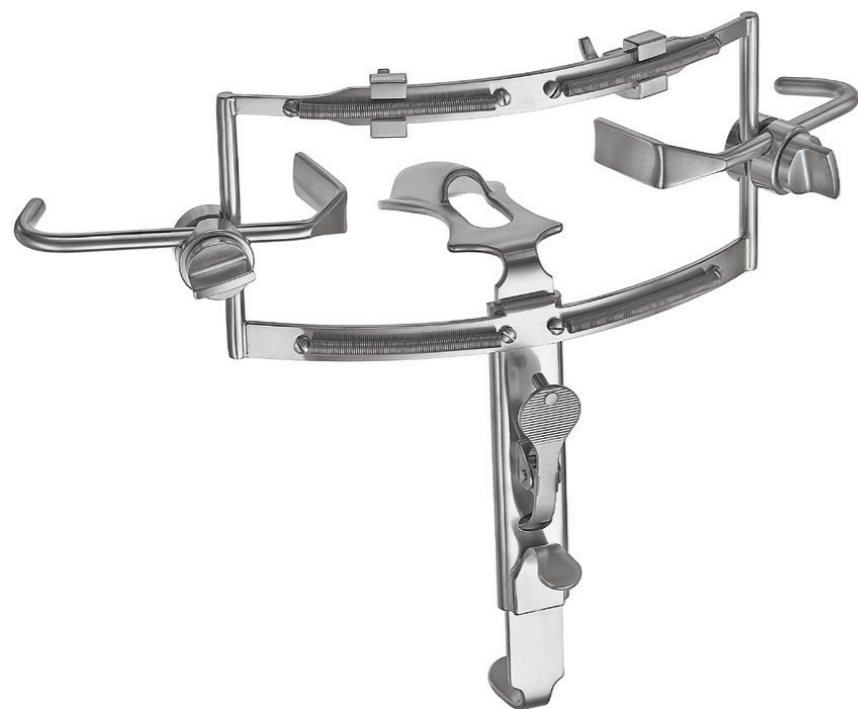

½

DINGMANN

48.330.00 14,5 cm | 5¾"

komplett mit Rahmen, 3 Zungendrucker, 2 Seitenvalven und 2 Zahnplatten
complete with frame, 3 tongue depressors, 2 lateral blades and 2 tooth plates
complet avec cadre, 3 abaisse-langue, 2 valves latérales et 2 plaques dentaires
completo con bastidor, 3 abajalengua, 2 valvas laterales y 2 placas dentales
completo con telaio, 3 abassalingua, 2 valve laterali e 2 placche per denti

48.330.09 14,5 cm | 5¾"

nur Rahmen
only frame
seulement cadre
sólo bastidor
solo telaio



½

48.330.01 13,5 cm | 5¼" 65 x 25 mm



½

48.330.02 13,5 cm | 5¼" 70 x 29 mm



½

48.330.03 13,5 cm | 5¼" 80 x 32 mm

Zungendrucker, gefenestertes Blatt für Absaugung
tongue depressor, fenestrated blade for suction
abaisse-langue, lame fenêtrée pour aspiration
abajalengua, hoja fenestrada para succión
abassalingua, lama con finestra per aspirazione



Bruststütze
chest support
support de poitrine
soporte de pecho
supporto per petto

½

KILNER-DOUGHTY

48.314.00 Höhe verstellbar
adjustable height
hauteur réglable
altura ajustable
altezza regolabile



½

COLLIN

48.250.16 16 cm | 6¼"
48.250.18 18 cm | 7"



½

YOUNG

48.255.16 16 cm | 6¼"
48.255.99 Gummipolster (Paar)
rubber inserts (pair)
rembourrage en caoutchouc (paire)
bocas de goma (par)
cuscino di gomma (paio)

Zungenzangen
tongue holding forceps
pinces tire-langues
pinzas tira-lengua
pinze per lingua

Fingerschutz
finger protector
doigtiers
dedal
ditale



LANGENBECK

48.371.01 ø 17 - 21 mm

Serviettenhalter
napkin holder
porte-serviette
servilletero
portatovaglioli



ADAMS

48.367.00

Tamponstopfer
gauze packer
porte-tampon
taponeador
tamponatori



LUNIATSCHEK

50.151.19 19 cm 7½"

11

ZAHNZANGEN

EXTRACTING FORCEPS
DAVIERS
PINZAS DE EXTRACCIÓN
PINZE PER ESTRAZIONE

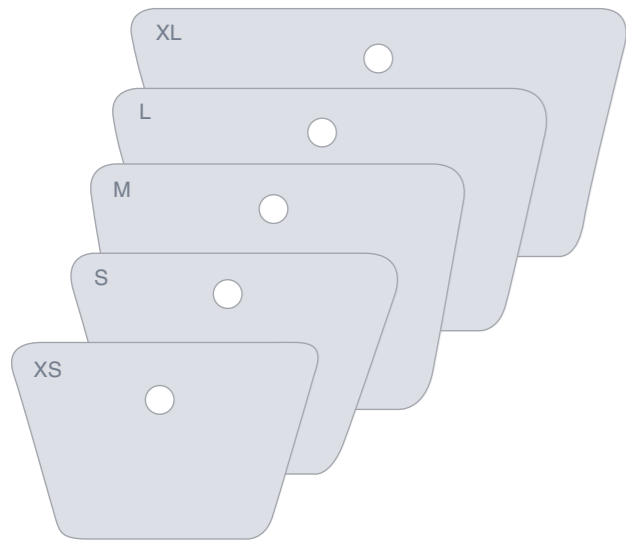
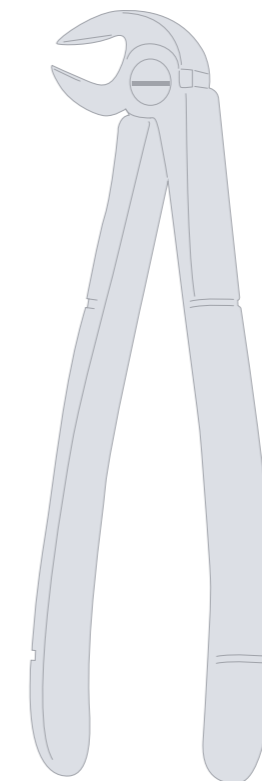

- XL extra groß, für Zahnlose
extra large, for edentulous
très grand, pour édentées
muy grande, para desdentados
molto grande, per sdentati
- L groß, für Erwachsene
large, for adults
grand, pour adultes
grande, para adultos
grande, per adulti
- M normal, für Erwachsene
regular, for adults
regulier, pour adultes
regular, para adultos
regolare, per adulti
- S klein, für Kinder
small, for children
petit, pour enfants
pequeño, para niños
piccolo, per bambini
- XS klein, für Kleinkinder
small, for babies
petit, pour bébés
pequeño, para bebés
piccolo, per neonati



MCKESSON

48.362.58	XS	kunststoffbeschichteter Metallrahmen ohne Kette
48.362.56	S	plastic coated metal frame without chain
48.362.54	M	cadre métallique avec revêtement synthétique sans chaîne
48.362.52	L	cuadro metálico, cubierto de plástico sin cadena
48.362.50	XL	telaio metallico, ricoperto in plastica senza catena



ZAHNZANGEN, ENGLISCHE FORM
 EXTRACTING FORCEPS, ENGLISH PATTERN
 DAVIERS, FORME ANGLAISE
 PINZAS DE EXTRACCIÓN, FORMA INGLESA
 PINZE PER ESTRAZIONE, FORMA INGLESE

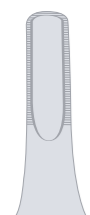

80.001.00 N° 1

80.002.00 N° 2

80.004.00 N° 4

ZAHNZANGEN, ENGLISCHE FORM
 EXTRACTING FORCEPS, ENGLISH PATTERN
 DAVIERS, FORME ANGLAISE
 PINZAS DE EXTRACCIÓN, FORMA INGLESA
 PINZE PER ESTRAZIONE, FORMA INGLESE

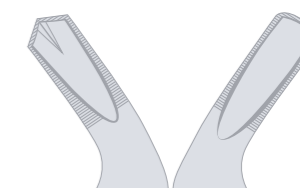
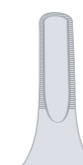

80.007.00 N° 7

80.013.00 N° 13

80.017.00 N° 17



ZAHNZANGEN, ENGLISCHE FORM
 EXTRACTING FORCEPS, ENGLISH PATTERN
 DAVIERS, FORME ANGLAISE
 PINZAS DE EXTRACCIÓN, FORMA INGLESA
 PINZE PER ESTRAZIONE, FORMA INGLESE

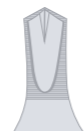
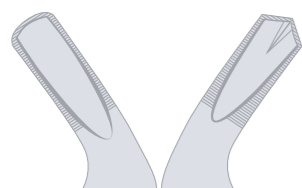

80.018.00 N° 18



80.018.01 N° 18A



80.022.00 N° 22

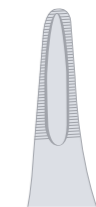
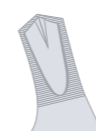

80.023.00 N° 23



80.024.00 N° 24



80.029.00 N° 29

ZAHNZANGEN, ENGLISCHE FORM
 EXTRACTING FORCEPS, ENGLISH PATTERN
 DAVIERS, FORME ANGLAISE
 PINZAS DE EXTRACCIÓN, FORMA INGLESA
 PINZE PER ESTRAZIONE, FORMA INGLESE





ZAHNZANGEN, ENGLISCHE FORM
 EXTRACTING FORCEPS, ENGLISH PATTERN
 DAVIERS, FORME ANGLAISE
 PINZAS DE EXTRACCIÓN, FORMA INGLESA
 PINZE PER ESTRAZIONE, FORMA INGLESE

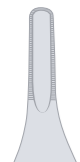

80.033.00 N° 33

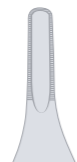

80.033.01 N° 33A



80.033.03 N° 33C

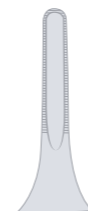

80.033.06 N° 33M

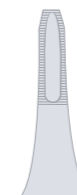

80.034.00 N° 34

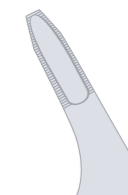

80.035.00 N° 35

tiefgreifend
 deep-gripping
 profond
 profundo

tiefgreifend
 deep-gripping
 profond
 profundo

ZAHNZANGEN, ENGLISCHE FORM
 EXTRACTING FORCEPS, ENGLISH PATTERN
 DAVIERS, FORME ANGLAISE
 PINZAS DE EXTRACCIÓN, FORMA INGLESA
 PINZE PER ESTRAZIONE, FORMA INGLESE





ZAHNZANGEN, ENGLISCHE FORM
 EXTRACTING FORCEPS, ENGLISH PATTERN
 DAVIERS, FORME ANGLAISE
 PINZAS DE EXTRACCIÓN, FORMA INGLESA
 PINZE PER ESTRAZIONE, FORMA INGLESE

tiefgreifend
 deep-gripping
 profond
 profundo
 profundo

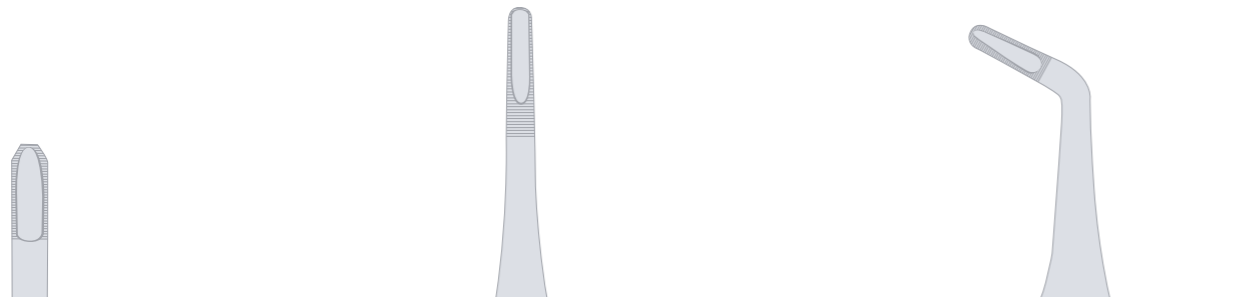

80.036.02 N° 36



80.041.00 N° 41



80.045.00 N° 45

tiefgreifend
 deep-gripping
 profond
 profundo
 profundo

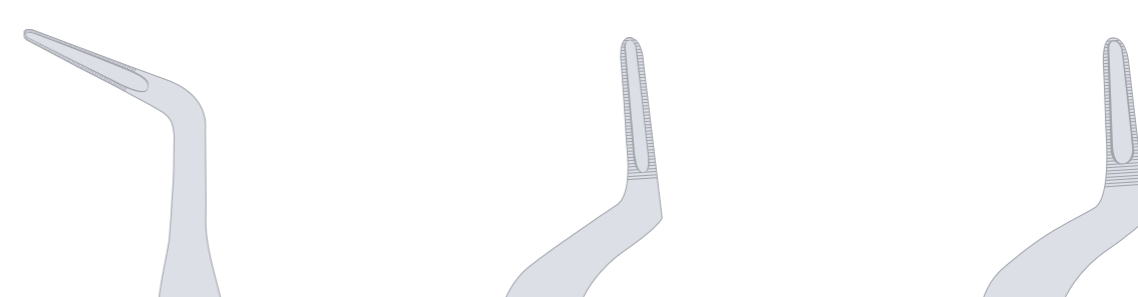

80.046.12 N° 46L



80.051.00 N° 51



80.051.01 N° 51A



ZAHNZANGEN, ENGLISCHE FORM
 EXTRACTING FORCEPS, ENGLISH PATTERN
 DAVIERS, FORME ANGLAISE
 PINZAS DE EXTRACCIÓN, FORMA INGLESA
 PINZE PER ESTRAZIONE, FORMA INGLESE



ZAHNZANGEN, ENGLISCHE FORM
 EXTRACTING FORCEPS, ENGLISH PATTERN
 DAVIERS, FORME ANGLAISE
 PINZAS DE EXTRACCIÓN, FORMA INGLESA
 PINZE PER ESTRAZIONE, FORMA INGLESE

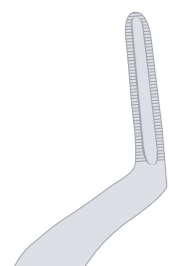

80.051.03 N° 51C



80.053.00 N° 53



80.055.00 N° 55



80.067.00 N° 67



80.073.00 N° 73



80.074.00 N° 74

ZAHNZANGEN, ENGLISCHE FORM
 EXTRACTING FORCEPS, ENGLISH PATTERN
 DAVIERS, FORME ANGLAISE
 PINZAS DE EXTRACCIÓN, FORMA INGLESA
 PINZE PER ESTRAZIONE, FORMA INGLESE





ZAHNZANGEN, ENGLISCHE FORM
 EXTRACTING FORCEPS, ENGLISH PATTERN
 DAVIERS, FORME ANGLAISE
 PINZAS DE EXTRACCIÓN, FORMA INGLESA
 PINZE PER ESTRAZIONE, FORMA INGLESE

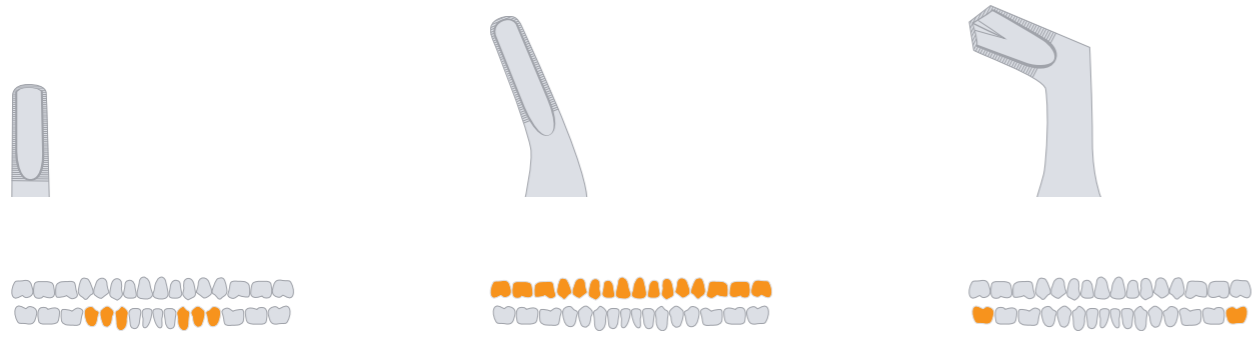

80.075.00 N° 75



80.076.00 N° 76



80.079.00 N° 79

ZAHNZANGEN, ENGLISCHE FORM
 EXTRACTING FORCEPS, ENGLISH PATTERN
 DAVIERS, FORME ANGLAISE
 PINZAS DE EXTRACCIÓN, FORMA INGLESA
 PINZE PER ESTRAZIONE, FORMA INGLESE



für abgebrochenen Kronen
 for broken crowns
 pour couronnes cassées
 para coronas dañadas
 per corone spezzate

für abgebrochenen Kronen
 for broken crowns
 pour couronnes cassées
 para coronas dañadas
 per corone spezzate



80.086.01 N° 86A



80.087.00 N° 87



80.089.00 N° 89



ZAHNZANGEN, ENGLISCHE FORM
 EXTRACTING FORCEPS, ENGLISH PATTERN
 DAVIERS, FORME ANGLAISE
 PINZAS DE EXTRACCIÓN, FORMA INGLESA
 PINZE PER ESTRAZIONE, FORMA INGLESE

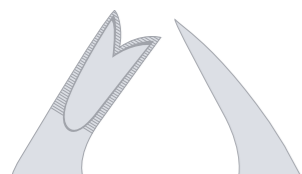

80.090.00 N° 90

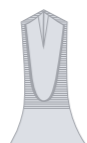

WOOD
 80.099.00 N° 99



80.333.09 N° 333S



80.233.00 N° 233



80.235.00 N° 235

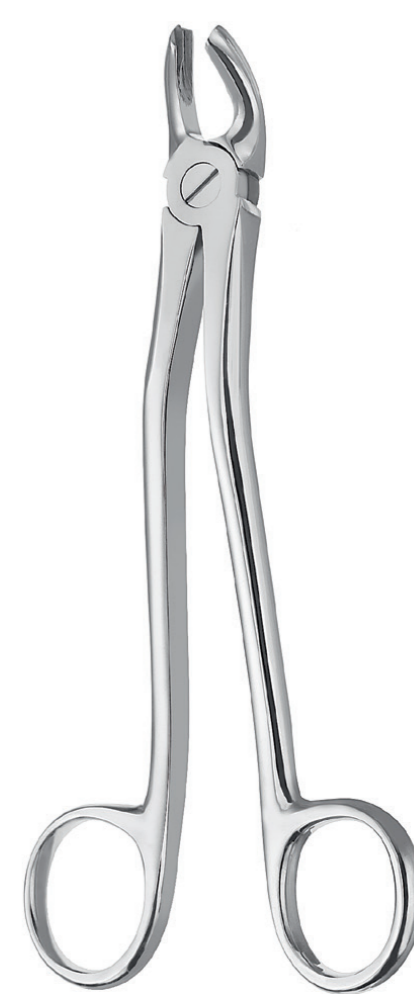

KÖHLERT-WHITE
 80.198.00 N° 198

ZAHNZANGEN, ENGLISCHE FORM
 EXTRACTING FORCEPS, ENGLISH PATTERN
 DAVIERS, FORME ANGLAISE
 PINZAS DE EXTRACCIÓN, FORMA INGLESA
 PINZE PER ESTRAZIONE, FORMA INGLESE





ZAHNZANGEN, ENGLISCHE FORM
 EXTRACTING FORCEPS, ENGLISH PATTERN
 DAVIERS, FORME ANGLAISE
 PINZAS DE EXTRACCIÓN, FORMA INGLESA
 PINZE PER ESTRAZIONE, FORMA INGLESE

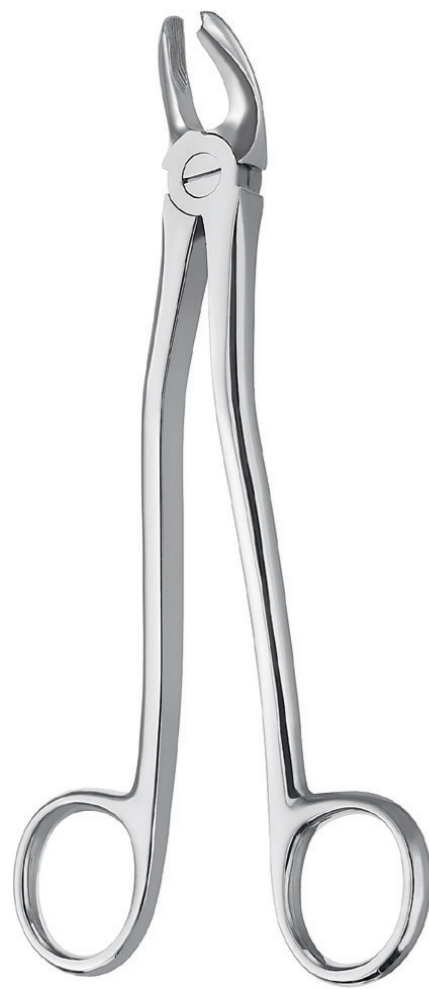
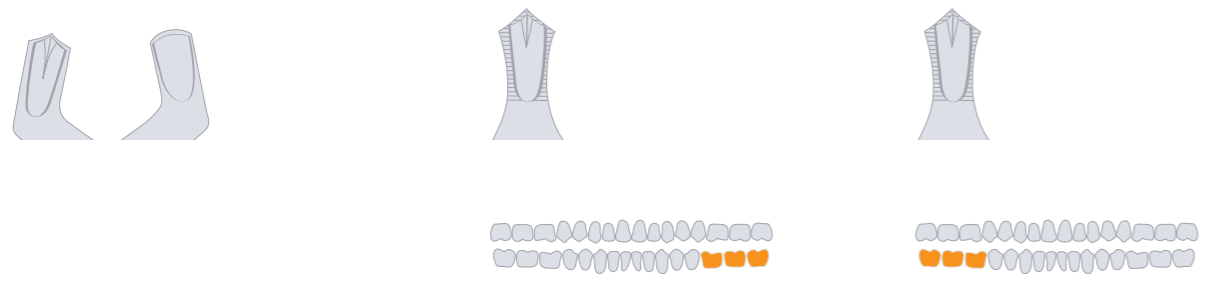

KÖHLERT-WHITE
 80.199.00 N° 199



ROUTURIER
 80.422.05



ROUTURIER
 80.422.08

WURZELSPLITTERZANGEN
 ROOT SPLITTER FORCEPS
 DAVIERS À FRAGMENTS POUR RACINES DENTAIRES
 PINZAS PARA FRAGMENTOS DE RACÍCES
 PINZE PER FRAGMENTI DE RADICI



81.300.00 N° 300



81.301.00 N° 301



ZAHNZANGEN, AMERIKANISCHE FORM
 EXTRACTING FORCEPS, AMERICAN PATTERN
 DAVIERS, FORME AMÉRICAINNE
 PINZAS DE EXTRACCIÓN, FORMA AMERICANA
 PINZE PER ESTRAZIONE, FORMA AMERICANA

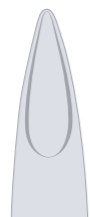
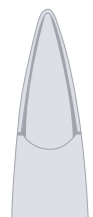

81.001.00 N° 1



HENAHAN
 81.001.01 N° 1A



81.001.02 N° 1B



MILWAUKEE
 81.003.00 N° 3



WOOD-WARD
 81.003.04 N° 3FH



WOOD-WARD
 81.003.09 N° 3FS



ZAHNZANGEN, AMERIKANISCHE FORM
 EXTRACTING FORCEPS, AMERICAN PATTERN
 DAVIERS, FORME AMÉRICAINNE
 PINZAS DE EXTRACCIÓN, FORMA AMERICANA
 PINZE PER ESTRAZIONE, FORMA AMERICANA

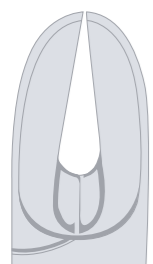

Spaltzange
 splitting forceps
 daviers pour séparer les racines
 pinzas para separar raíces
 tenaglie per scindere le radici

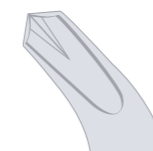

PHYSICK
 81.005.00 N° 5

81.006.00 N° 6

81.010.04 N° 10H

81.010.09 N° 10S

HARRIS
 81.015.00 N° 15

HARRIS
 81.016.00 N° 16



81.016.09 N° 16S

81.017.00 N° 17

HARRIS
 81.018.05 N° 18L



HARRIS
 81.018.08 N° 18R

81.023.00 N° 23

HARRIS
 81.024.00 N° 24



ZAHNZANGEN, AMERIKANISCHE FORM
 EXTRACTING FORCEPS, AMERICAN PATTERN
 DAVIERS, FORME AMÉRICAINNE
 PINZAS DE EXTRACCIÓN, FORMA AMERICANA
 PINZE PER ESTRAZIONE, FORMA AMERICANA

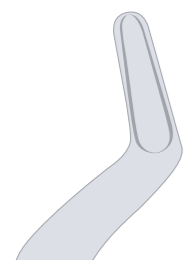

81.032.00 N° 32

81.032.01 N° 32A

81.053.05 N° 53L

ZAHNZANGEN, AMERIKANISCHE FORM
 EXTRACTING FORCEPS, AMERICAN PATTERN
 DAVIERS, FORME AMÉRICAINNE
 PINZAS DE EXTRACCIÓN, FORMA AMERICANA
 PINZE PER ESTRAZIONE, FORMA AMERICANA

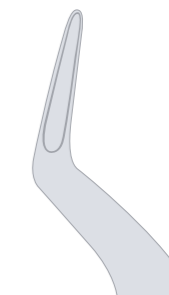

81.053.08 N° 53R

81.062.00 N° 62

81.065.00 N° 65



ZAHNZANGEN, AMERIKANISCHE FORM
 EXTRACTING FORCEPS, AMERICAN PATTERN
 DAVIERS, FORME AMÉRICAINNE
 PINZAS DE EXTRACCIÓN, FORMA AMERICANA
 PINZE PER ESTRAZIONE, FORMA AMERICANA

Wurzelsplitter und kleine Wurzeln
 root fragments and small roots
 fragments de racines et racines fines
 fragmentos de raíces y raíces muy delgadas
 frammenti di radici e radici piccole



81.069.00 N° 69

THOMAS
 81.085.00 N° 85

THOMAS
 81.085.01 N° 85A

ZAHNZANGEN, AMERIKANISCHE FORM
 EXTRACTING FORCEPS, AMERICAN PATTERN
 DAVIERS, FORME AMÉRICAINNE
 PINZAS DE EXTRACCIÓN, FORMA AMERICANA
 PINZE PER ESTRAZIONE, FORMA AMERICANA

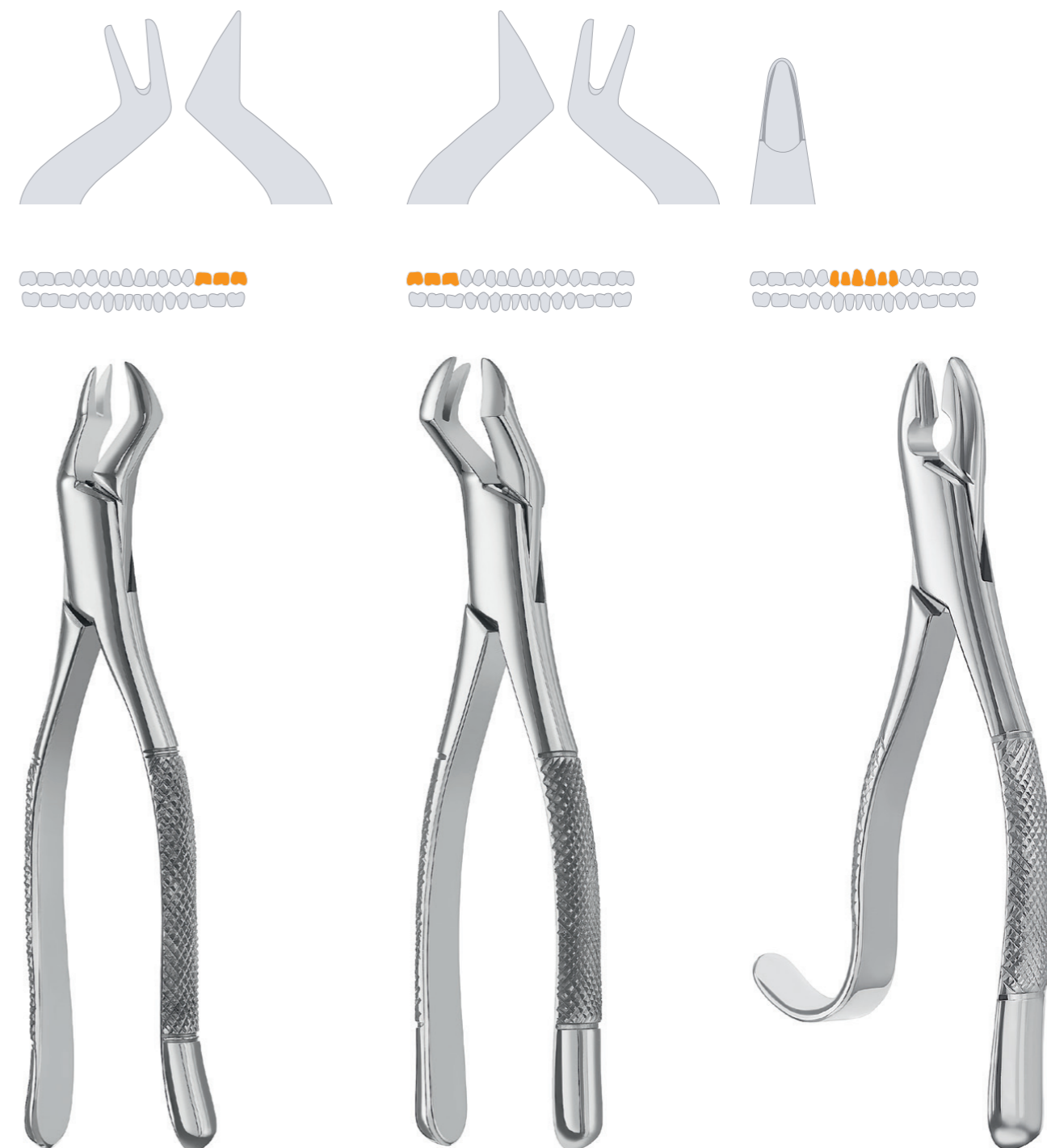

NEVIUS
 81.088.05 N° 88L

NEVIUS
 81.088.08 N° 88R

KELLS
 81.099.01 N° 99A



ZAHNZANGEN, AMERIKANISCHE FORM
 EXTRACTING FORCEPS, AMERICAN PATTERN
 DAVIERS, FORME AMÉRICAINNE
 PINZAS DE EXTRACCIÓN, FORMA AMERICANA
 PINZE PER ESTRAZIONE, FORMA AMERICANA

ZAHNZANGEN, AMERIKANISCHE FORM
 EXTRACTING FORCEPS, AMERICAN PATTERN
 DAVIERS, FORME AMÉRICAINNE
 PINZAS DE EXTRACCIÓN, FORMA AMERICANA
 PINZE PER ESTRAZIONE, FORMA AMERICANA

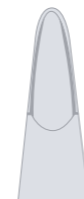
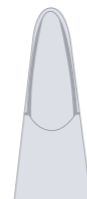
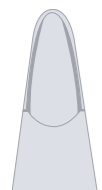

KELLS
 81.099.03 N° 99C

HULL
 81.101.00 N° 101

81.110.04 N° 10H

81.110.09 N° 10S

CRYER
 81.150.00 N° 150

CRYER
 81.150.01 N° 150A



ZAHNZANGEN, AMERIKANISCHE FORM
 EXTRACTING FORCEPS, AMERICAN PATTERN
 DAVIERS, FORME AMÉRICAINNE
 PINZAS DE EXTRACCIÓN, FORMA AMERICANA
 PINZE PER ESTRAZIONE, FORMA AMERICANA

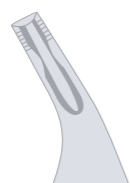
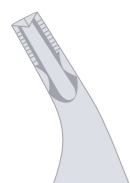

CRYER
 81.150.02 N° 150X

CRYER
 81.150.03 N° 150AB

CRYER
 81.151.00 N° 151

ZAHNZANGEN, AMERIKANISCHE FORM
 EXTRACTING FORCEPS, AMERICAN PATTERN
 DAVIERS, FORME AMÉRICAINNE
 PINZAS DE EXTRACCIÓN, FORMA AMERICANA
 PINZE PER ESTRAZIONE, FORMA AMERICANA



CRYER
 81.151.01 N° 151A

CRYER
 81.151.02 N° 151X

CRYER
 81.151.03 N° 151AB



ZAHNZANGEN, AMERIKANISCHE FORM
 EXTRACTING FORCEPS, AMERICAN PATTERN
 DAVIERS, FORME AMÉRICAINNE
 PINZAS DE EXTRACCIÓN, FORMA AMERICANA
 PINZE PER ESTRAZIONE, FORMA AMERICANA



CRYER
 81.151.08 N° 151AS



81.201.00 N° 201



81.203.00 N° 203



81.210.04 N° 210H



81.210.09 N° 210S

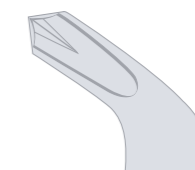

81.217.00 N° 217

ZAHNZANGEN, AMERIKANISCHE FORM
 EXTRACTING FORCEPS, AMERICAN PATTERN
 DAVIERS, FORME AMÉRICAINNE
 PINZAS DE EXTRACCIÓN, FORMA AMERICANA
 PINZE PER ESTRAZIONE, FORMA AMERICANA



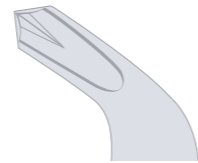
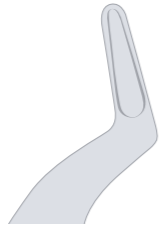
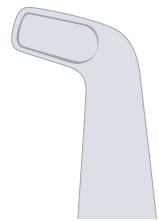

81.222.00 N° 222

81.286.00 N° 286

81.287.00 N° 287

81.288.00 N° 288

▶ Wenn Sie Interesse an Zahnzangen Haftprofil haben, kontaktieren Sie uns gerne.
 In case you are interested in non-slip extracting forceps, please do not hesitate to contact us.
 Si vous vous intéressez aux daviers rententifs, n'hésitez pas à nous contacter.
 En caso de que se interesen por forceps con perfil ret, no tardarían en contactarnos.
 Se avete interesse a pinze dentali profilo adesione, non esitate a contattarci.



WURZELSCHRAUBEN
 ROOT SCREWS
 VIS À RACINES
 TORNILLOS PARA RAÍCES
 VITI PER RADICI



MORRISON

- 81.820.00 N° 0
- 81.820.01 N° 1
- 81.820.02 N° 2
- 81.820.03 N° 3

12

KINDERZAHNZANGEN

EXTRACTING FORCEPS FOR CHILDREN
 DAVIERS POUR ENFANTS
 PINZAS DE EXTRACCIÓN PARA NIÑOS
 PINZE PER ESTRAZIONE PER BAMBINI

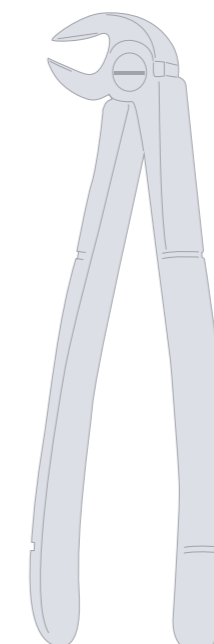



KINDERZAHNZANGEN, ENGLISCHE FORM
 EXTRACTING FORCEPS FOR CHILDREN, ENGLISH PATTERN
 DAVIERS POUR ENFANTS, FORME ANGLAISE
 FÓRCEPS DENTALES PARA NIÑOS, FORMA INGLESA
 PINZE PER ESTRAZIONE PER BAMBINI, FORMA INGLESE



KLEIN
 80.703.00 N° 3



KLEIN
 80.705.00 N° 5



KLEIN
 80.706.00 N° 6



KLEIN
 80.707.00 N° 7



80.613.09 N° 13S



80.622.09 N° 22S

KINDERZAHNZANGEN, ENGLISCHE FORM
 EXTRACTING FORCEPS FOR CHILDREN, ENGLISH PATTERN
 DAVIERS POUR ENFANTS, FORME ANGLAISE
 FÓRCEPS DENTALES PARA NIÑOS, FORMA INGLESA
 PINZE PER ESTRAZIONE PER BAMBINI, FORMA INGLESE





KINDERZAHNZANGEN, ENGLISCHE FORM
 EXTRACTING FORCEPS FOR CHILDREN, ENGLISH PATTERN
 DAVIERS POUR ENFANTS, FORME ANGLAISE
 FÓRCEPS DENTALES PARA NIÑOS, FORMA INGLESA
 PINZE PER ESTRAZIONE PER BAMBINI, FORMA INGLESE



80.629.09 N° 29S

80.630.09 N° 30S

80.633.09 N° 33S

KINDERZAHNZANGEN, ENGLISCHE FORM
 EXTRACTING FORCEPS FOR CHILDREN, ENGLISH PATTERN
 DAVIERS POUR ENFANTS, FORME ANGLAISE
 FÓRCEPS DENTALES PARA NIÑOS, FORMA INGLESA
 PINZE PER ESTRAZIONE PER BAMBINI, FORMA INGLESE



80.637.00 N° 37

80.638.00 N° 38

80.639.00 N° 39



KINDERZAHNZANGEN, ENGLISCHE FORM
 EXTRACTING FORCEPS FOR CHILDREN, ENGLISH PATTERN
 DAVIERS POUR ENFANTS, FORME ANGLAISE
 FÓRCEPS DENTALES PARA NIÑOS, FORMA INGLESA
 PINZE PER ESTRAZIONE PER BAMBINI, FORMA INGLESE

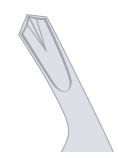

80.639.01 N° 39A

80.639.05 N° 39L

80.639.08 N° 39R



80.640.00 N° 40

80.651.09 N° 51S

KLEIN
 80.751.09 N° 51S

KINDERZAHNZANGEN, ENGLISCHE FORM
 EXTRACTING FORCEPS FOR CHILDREN, ENGLISH PATTERN
 DAVIERS POUR ENFANTS, FORME ANGLAISE
 FÓRCEPS DENTALES PARA NIÑOS, FORMA INGLESA
 PINZE PER ESTRAZIONE PER BAMBINI, FORMA INGLESE





KINDERZAHNZANGEN, ENGLISCHE FORM
 EXTRACTING FORCEPS FOR CHILDREN, ENGLISH PATTERN
 DAVIERS POUR ENFANTS, FORME ANGLAISE
 FÓRCEPS DENTALES PARA NIÑOS, FORMA INGLESA
 PINZE PER ESTRAZIONE PER BAMBINI, FORMA INGLESE



LAWRENCE-READ
 80.676.09 N° 76S



KLEIN
 80.737.00 N° 137



KLEIN
 80.739.00 N° 139

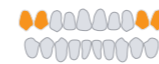

80.817.09 N° 17SK



80.823.09 N° 23SK



81.150.08 N° 150AS

KINDERZAHNZANGEN, AMERIKANISCHE FORM
 EXTRACTING FORCEPS FOR CHILDREN, AMERICAN PATTERN
 DAVIERS POUR ENFANTS, FORME AMÉRICAINNE
 FÓRCEPS DENTALES PARA NIÑOS, FORMA AMERICANA
 PINZE PER ESTRAZIONE PER BAMBINI, FORMA AMERICANA





KINDERZAHNZANGEN, AMERIKANISCHE FORM
 EXTRACTING FORCEPS FOR CHILDREN, AMERICAN PATTERN
 DAVIERS POUR ENFANTS, FORME AMÉRICAINNE
 FÓRCEPS DENTALES PARA NIÑOS, FORMA AMERICANA
 PINZE PER ESTRAZIONE PER BAMBINI, FORMA AMERICANA

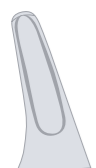

CRYER
 81.150.09 N° 150S



80.850.09 N° 150SK



CRYER
 81.151.09 N° 151 S



80.851.09 N° 151SK

KINDERZAHNZANGEN, AMERIKANISCHE FORM
 EXTRACTING FORCEPS FOR CHILDREN, AMERICAN PATTERN
 DAVIERS POUR ENFANTS, FORME AMÉRICAINNE
 FÓRCEPS DENTALES PARA NIÑOS, FORMA AMERICANA
 PINZE PER ESTRAZIONE PER BAMBINI, FORMA AMERICANA





MILCHZAHNPINZETTEN
 FORCEPS FOR DECIDUOUS TEETH
 PINCES À DENTS DE LAIT
 PINZAS PARA DIENTES DE LECHE
 PINZE PER DENTI DI LATTE



1/2

ALBRECHT

81.811.16 16 cm 6 1/4"



1/2

ALBRECHT

81.812.16 16 cm 6 1/4"

13

WURZELHEBER
 ROOT ELEVATORS
 ELÉVATEURS DE RACINES
 ELEVADORES PARA RAÍCES
 LEVE PER RADICI

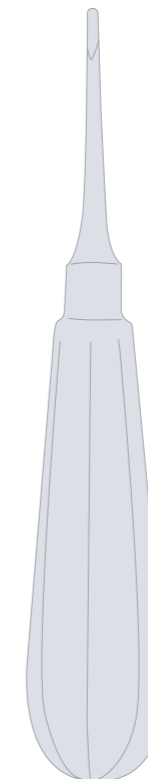

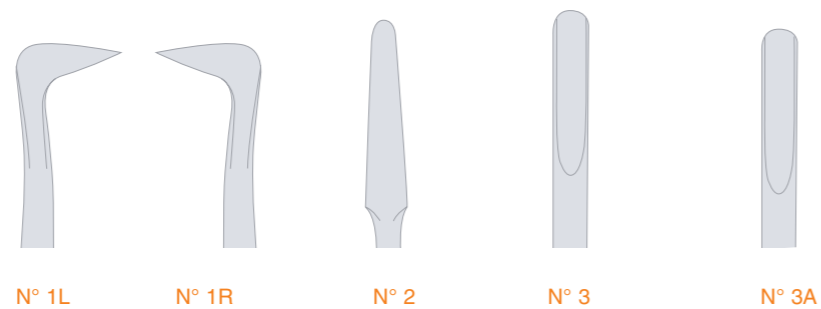

N° 1L N° 1R N° 2 N° 3 N° 3A

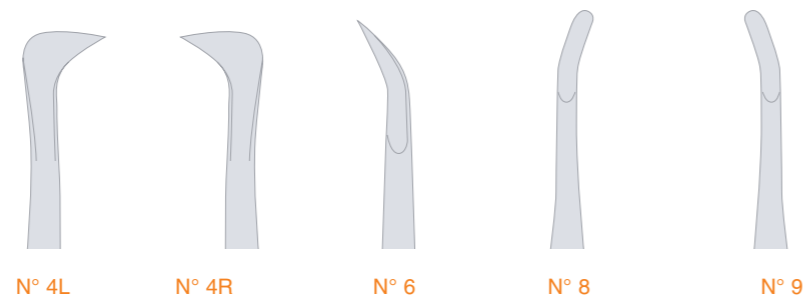

N° 4L N° 4R N° 6 N° 8 N° 9

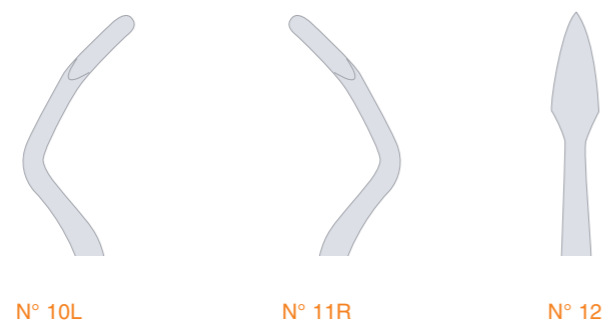

N° 10L N° 11R N° 12

1/4

82.001.05	N° 1L	SELDIN
82.001.08	N° 1R	SELDIN
82.002.00	N° 2	SELDIN
82.003.00	N° 3	SELDIN
82.003.01	N° 3A	CRYER
82.004.05	N° 4L	SELDIN
82.004.08	N° 4R	SELDIN
82.006.00	N° 6	CRANE-COGSWELL
82.008.00	N° 8	MILLER
82.009.00	N° 9	MILLER
82.010.00	N° 10L	MILLER-APEXO
82.011.00	N° 11R	MILLER-APEXO
82.012.00	N° 12	CRYER

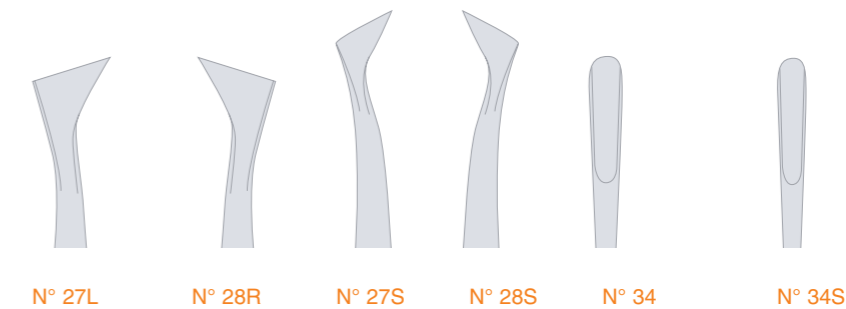

N° 27L N° 28R N° 27S N° 28S N° 34 N° 34S

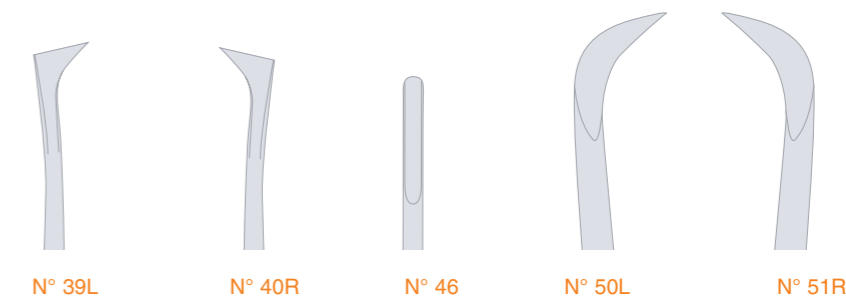

N° 39L N° 40R N° 46 N° 50L N° 51R

1/4

82.027.00	N° 27L	CRYER
82.028.00	N° 28R	CRYER
82.027.01	N° 27S	CRYER
82.028.01	N° 28S	CRYER
82.034.00	N° 34	SELDIN
82.034.09	N° 34S	SELDIN
82.039.00	N° 39L	CRYER
82.040.00	N° 40R	CRYER
82.046.00	N° 46	FLOHR
82.050.00	N° 50L	W.F-BARRY
82.051.00	N° 51R	W.F-BARRY

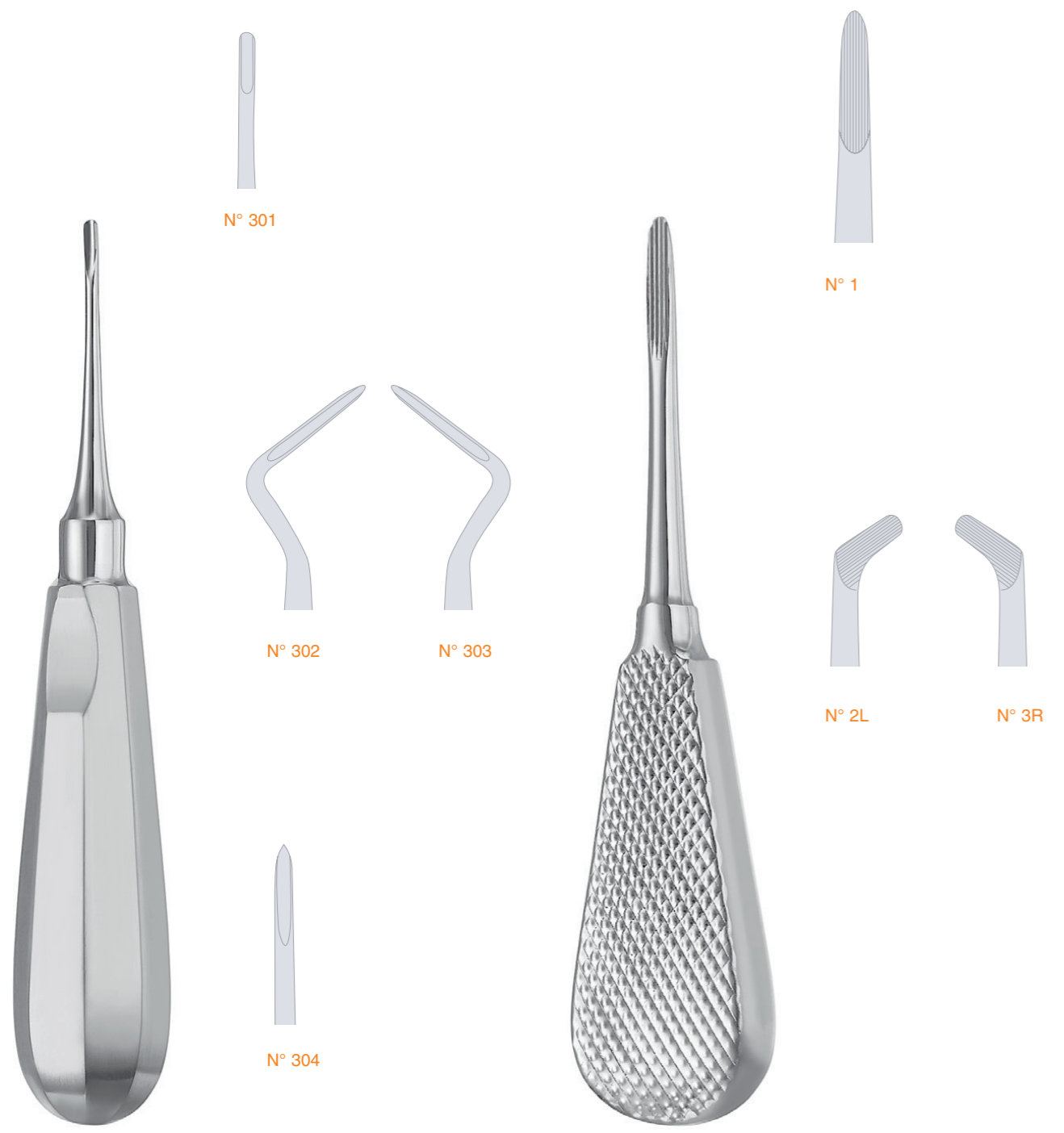

$\frac{1}{4}$			$\frac{1}{4}$		
82.301.00	N° 301	APICAL	COLEMANN	82.405.01	N° 1
82.302.00	N° 302	APICAL-FLOHR		82.405.02	N° 2L
82.303.00	N° 303	APICAL-FLOHR		82.405.03	N° 3R
82.304.00	N° 304	APICAL			



$\frac{1}{4}$			$\frac{1}{4}$		
WARWICK-JAMES			KOPP		
82.410.01	N° 1		82.414.01	N° 1	
82.410.02	N° 2L		82.414.02	N° 2	
82.410.03	N° 3R		82.414.03	N° 3	
			82.414.04	N° 4	



N° 1



N° 1



N° 2L



N° 3R



N° 2L



N° 3R



1/4

FLOHR

- 82.501.01 N° 1
- 82.501.02 N° 2L
- 82.501.03 N° 3R

1/4

FRIEDMANN

- 82.505.01 N° 1
- 82.505.02 N° 2L
- 82.505.03 N° 3R



N° 1



N° 2



N° 3L



N° 4R



1/4

HYLIN

- 82.508.01 N° 1
- 82.508.02 N° 2
- 82.508.03 N° 3L
- 82.508.04 N° 4R

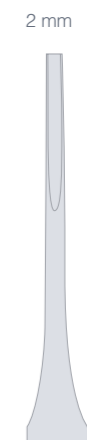

1

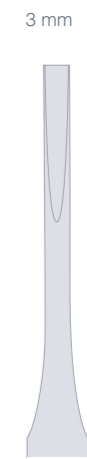

3

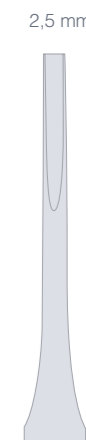

2



1/4

COUPLAND

- 82.540.20 1
- 82.540.25 2
- 82.540.30 3

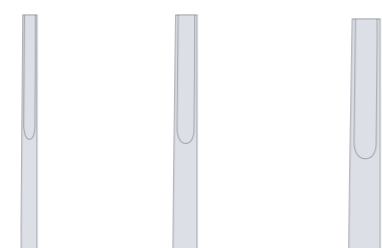

N° 0 N° 1 N° 2

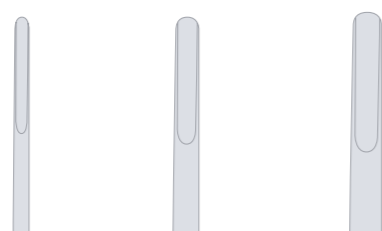

N° 0 N° 1 N° 2

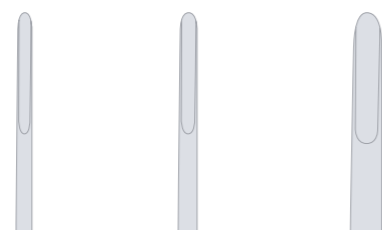

N° 0 N° 1 N° 2

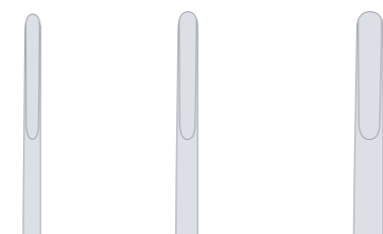

N° 0A N° 1A N° 2A

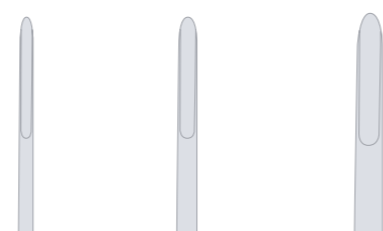

N° 0A N° 1A N° 2A



1/4

BEIN

82.511.00	N° 0	
82.511.01	N° 1	
82.511.02	N° 2	

82.512.00	N° 0	
82.512.01	N° 1	
82.512.02	N° 2	

82.513.00	N° 0	
82.513.01	N° 1	
82.513.02	N° 2	

82.514.00	N° 0A		
82.514.01	N° 1A		
82.514.02	N° 2A		

82.515.00	N° 0A		
82.515.01	N° 1A		
82.515.02	N° 2A		

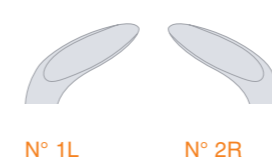

N° 1L N° 2R

1/4

LOOS

82.525.01	N° 1L
82.525.02	N° 2R



N° 1L N° 2R

1/4

KRALLENHEBER

82.571.01	N° 1L
82.571.02	N° 2R

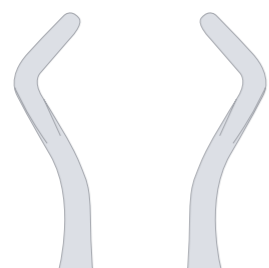

N° 1L N° 2R



N° 1

1/4
 POTT

- 82.567.01 N° 1L
- 82.567.02 N° 2R

1/4
 LECLUSE

- 82.561.01 N° 1



N° 320L N° 320R



N° 322L N° 322R



N° 370L N° 370R

1/4
 W. F. BARRY

- 82.533.20 N° 320L
- 82.533.21 N° 320R
- 82.533.22 N° 322L
- 82.533.23 N° 322R
- 82.533.70 N° 370L
- 82.533.71 N° 370R

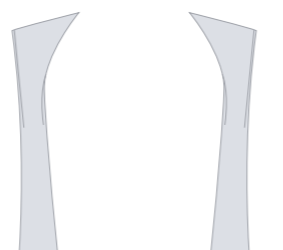

N° 11L



N° 11R

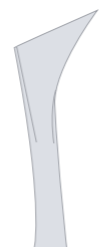

N° 13L



N° 13R



N° 14L



N° 14R



1/4

WINTER

82.551.05	N° 11L
82.551.08	N° 11R
82.553.05	N° 13L
82.553.08	N° 13R
82.554.05	N° 14L
82.554.08	N° 14R



1/4

HEIDBRINK

82.582.01	N° 1
82.582.02	N° 2L
82.582.03	N° 3R



N° 1



N° 2L



N° 3R



1/4

WEST-APIVCAL

82.583.09	N° 1
-----------	------



1/4

WEST HEIDBRINK-APIVCAL

82.587.01	N° 1
-----------	------

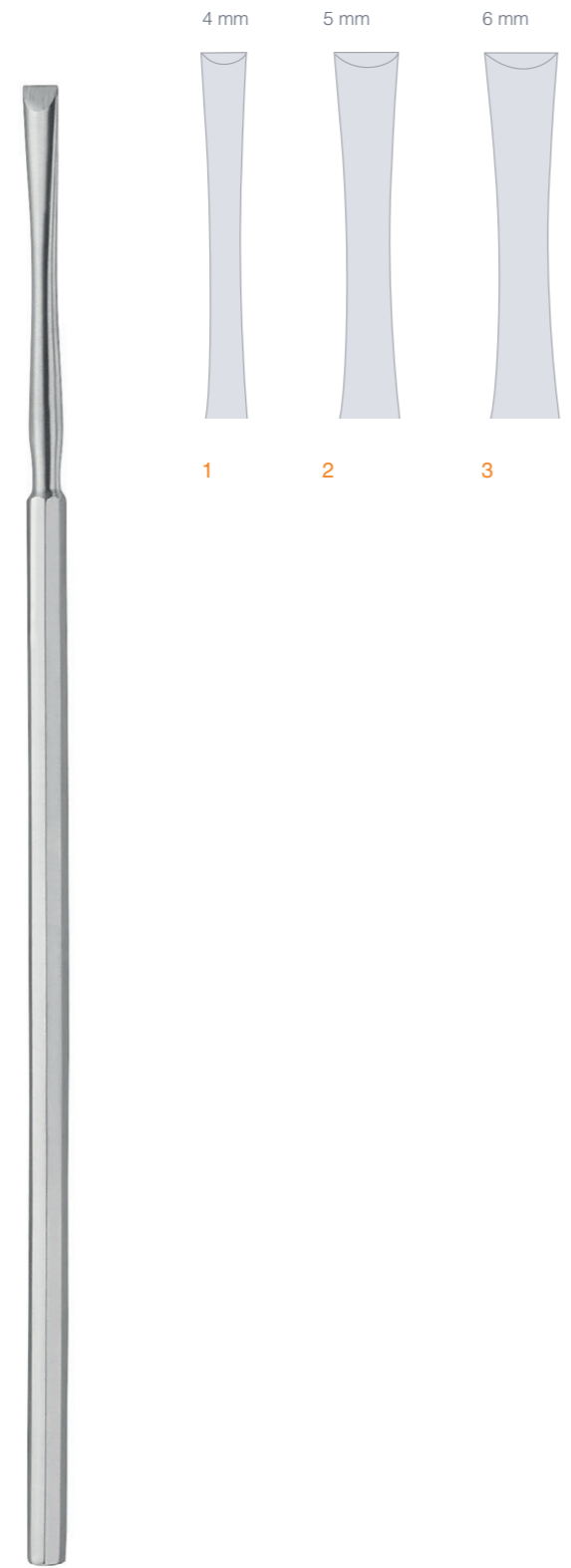
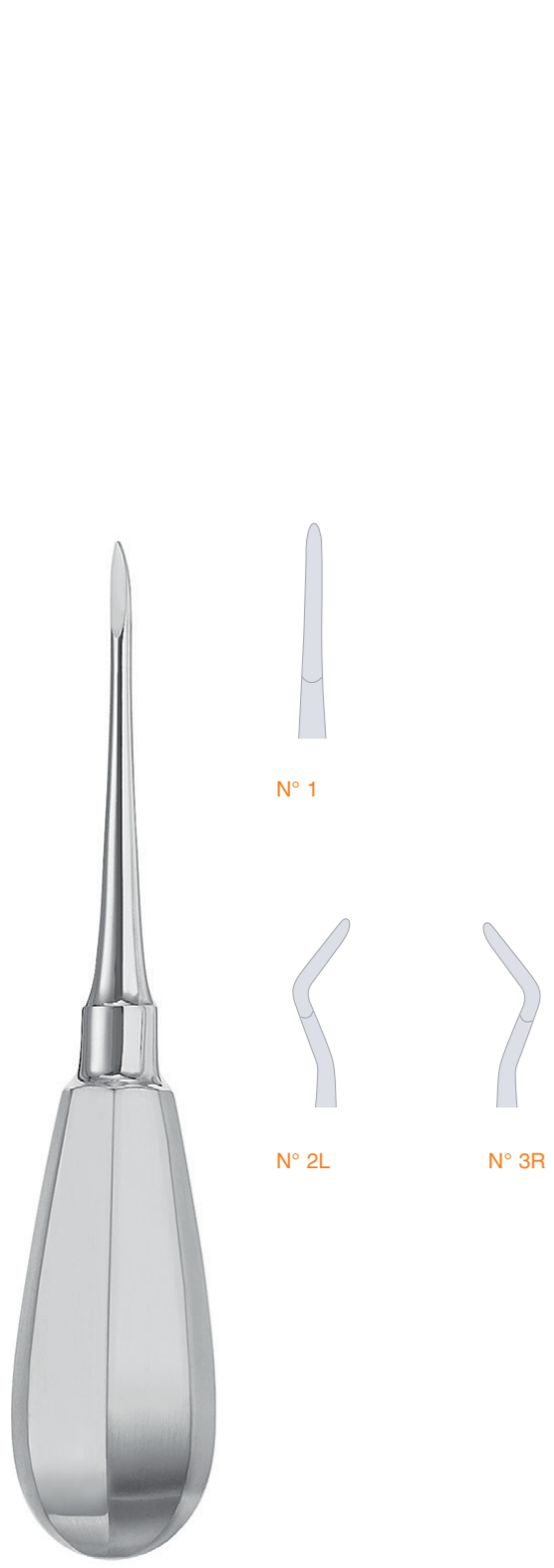

1/4
WINTER
 82.585.01 N° 1
 82.585.02 N° 2L
 82.585.03 N° 3R

1/4
BARRY
 82.590.04 1
 82.590.05 2
 82.590.06 3

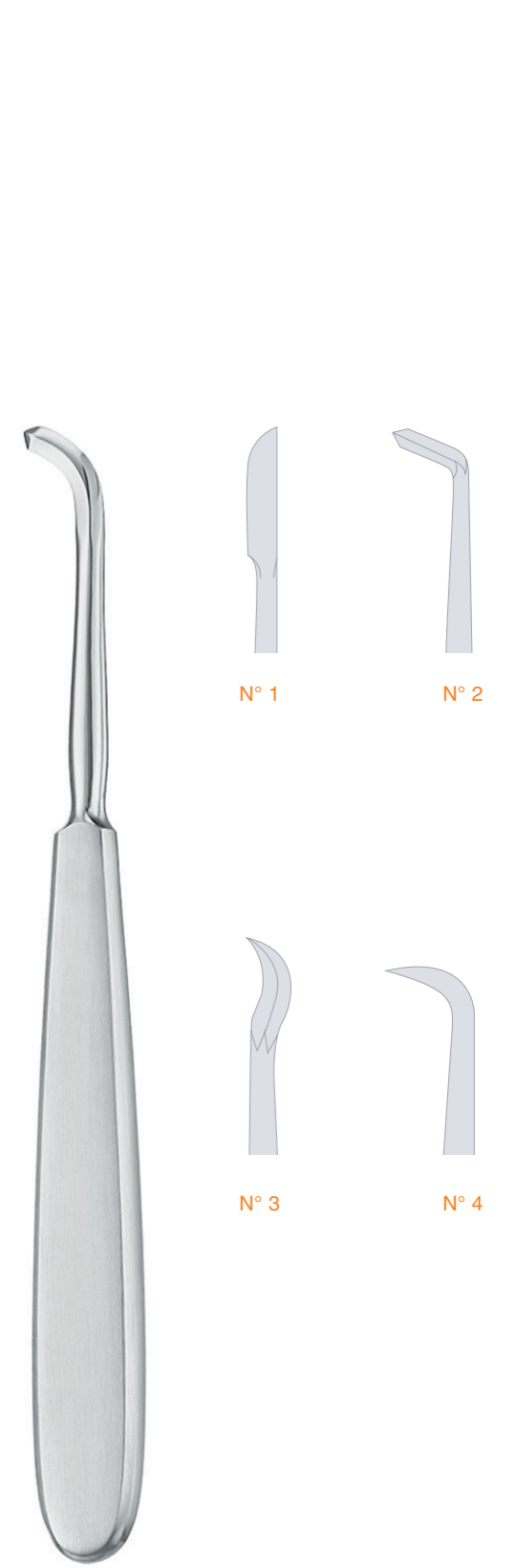
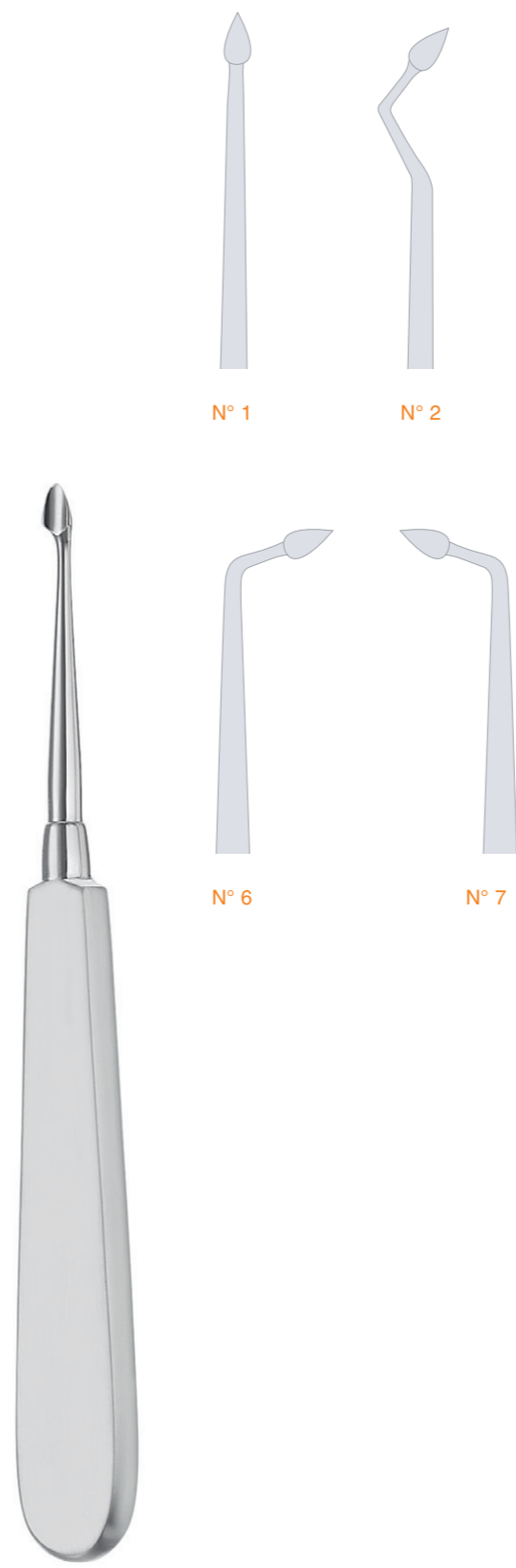

1/4
BERNARD
 82.581.01 N° 1
 82.581.02 N° 2
 82.581.06 N° 6
 82.581.07 N° 7

1/4
CHOMPRET
 82.577.01 N° 1
 82.577.02 N° 2
 82.577.03 N° 3
 82.577.04 N° 4



SYNDESMOTOME
SYNDESMOTOMES
SYNDESMOTOMES
SINDESMÓTOMOS
SINDESMOTOMI

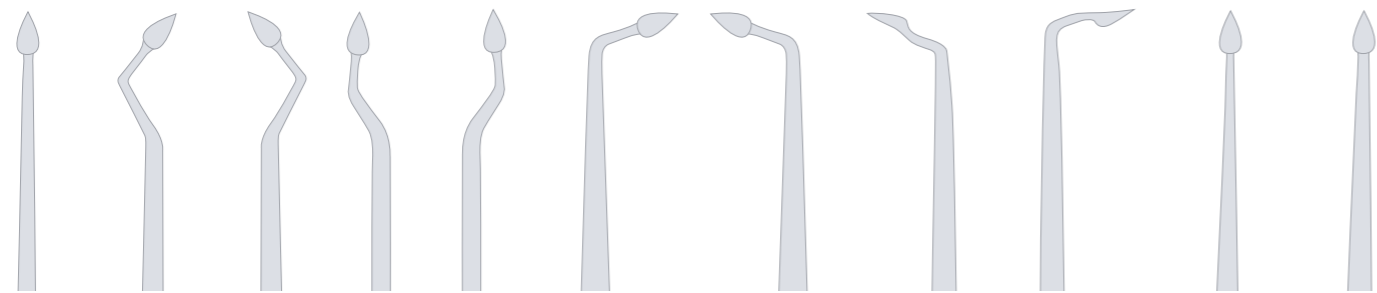

N° 1 N° 2L N° 3R N° 4L N° 5R N° 6L N° 7R N° 8 N° 9 N° 10 N° 11

82.580.01	N° 1	82.580.08	N° 8
82.580.02	N° 2L	82.580.09	N° 9
82.580.03	N° 3R	82.580.10	N° 10
82.580.04	N° 4L	82.580.11	N° 11
82.580.05	N° 5R		
82.580.06	N° 6L		
82.580.07	N° 7R		

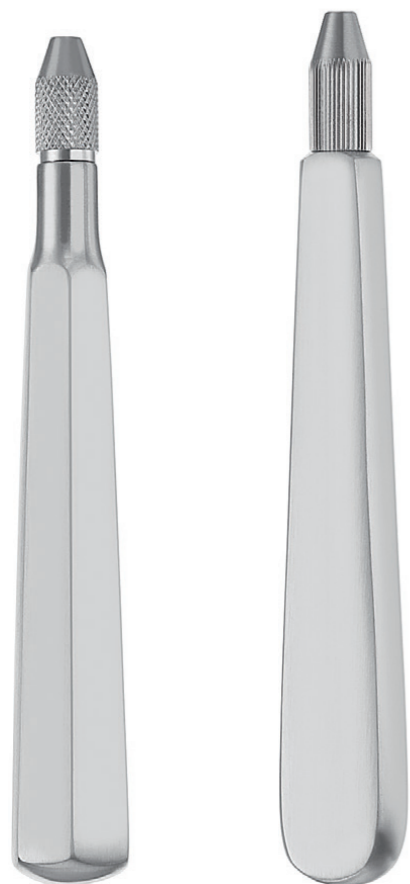

1/1
BERNARD
82.580.90

1/1
BERNARD
82.580.91



BERNARD
82.580.00 Satz set set juego serie

82.580.99 nur Behälter box only seulement boîte caja sola scatola sola

14

AMPULLENSPRITZEN
CARTRIDGE SYRINGES
SERINGUES POUR AMPOULE
JERINGAS DE CARTUCHO
SIRINGE DI CARPULE

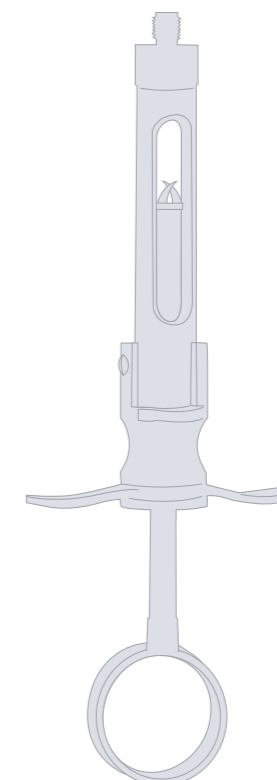

mit Aspiration
 with aspiration
 avec aspiration
 con aspiración
 con aspirazione

+ = inklusiv beider Aufsätze
 including both tips
 les deux embouts inclus
 ambos adaptadores incluidos
 ambedue addattatore incluso



82.603.51



82.603.52



1/1

82.600.18 1,8 ml +
 82.600.22 2,2 ml +

metrisches Gewinde
 metric thread
 filetage métrique
 rosca métrica
 filettatura metrica



1/1

82.601.18 1,8 ml +
 82.601.22 2,2 ml +

metrisches Gewinde
 metric thread
 filetage métrique
 rosca métrica
 filettatura metrica

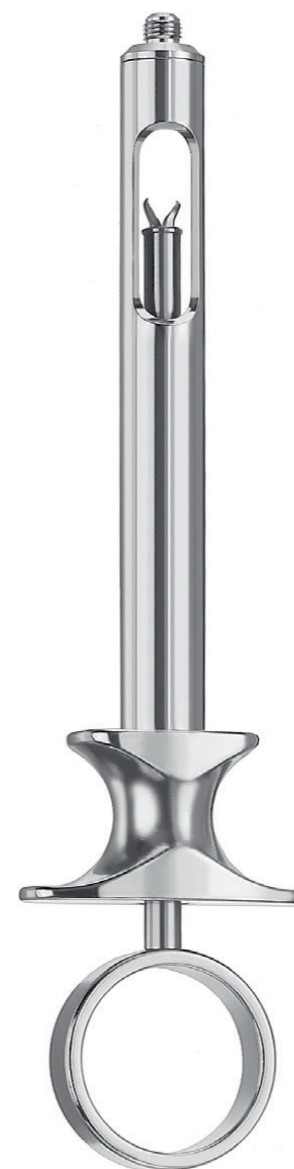

1/1

82.611.18 1,8 ml

US-Gewinde
 US thread
 filetage américain
 rosca tipo US
 filettatura tipo US



1/1

82.609.18 1,8 ml
 82.609.22 2,2 ml

US-Gewinde
 US thread
 filetage américain
 rosca tipo US
 filettatura tipo US



1/1

82.608.18 1,8 ml
 82.608.22 2,2 ml

metrisches Gewinde
 metric thread
 filetage métrique
 rosca métrica
 filettatura metrica

ohne Aspiration
 without aspiration
 sans aspiration
 sin aspiración
 senza aspirazione



1/1

1/1

82.606.18	1,8 ml
82.606.22	2,2 ml

82.602.18	1,8 ml	+
82.602.22	2,2 ml	+

US-Gewinde
 US thread
 filetage américain
 rosca tipo US
 filettatura tipo US

metrisches Gewinde
 metric thread
 filetage métrique
 rosca métrica
 filettatura metrica



1/1

82.603.18	1,8 ml	+
82.603.22	2,2 ml	+

metrisches Gewinde
 metric thread
 filetage métrique
 rosca métrica
 filettatura metrica



82.610.42	17 x 42
-----------	---------

12 Ampullennadeln
 12 cartridge needles
 12 aiguilles pour ampoules
 12 agujas para cartucho
 12 aghi per carpule



AMPULLENSPRITZEN
 CARTRIDGE SYRINGES
 SERINGUES POUR AMPOULE
 JERINGAS DE CARTUCHO
 SIRINGE DI CARPULE



1/1

82.652.01

1/1

82.652.00

selbstfüllend, Metall
 self filling, metal
 autoremplissant, métallique
 relleno automático, metálica
 riempire automatico, metallica



82.661.00

Luftbläser
 air blower
 souffleur d'air
 soplador de aire
 soffiatore d'aria

15

■ MUNDSPIEGEL
 MOUTH MIRRORS
 MIROIRS DENTAIRES
 ESPEJOS DE BOCA
 SPECCHIETTI DI BOCCA





flach
plane
plat
plano
plano

hohl, wirkt vergrößernd
concave, enlarging effect
creux, avec effet agrandissant
cóncavo, con efecto de aumento
cavo, con effetto di ingrandimento

metrisches Gewinde
metric thread
filetage métrique
rosca métrica
filettatura metrica

82.702.16	16 mm	N° 1	82.703.22	22 mm	N° 4
82.702.20	20 mm	N° 3	82.703.24	24 mm	N° 5
82.702.22	22 mm	N° 4			
82.702.24	24 mm	N° 5			



flach
plane
plat
plano
plano

hohl, wirkt vergrößernd
concave, enlarging effect
creux, avec effet agrandissant
cóncavo, con efecto de aumento
cavo, con effetto di ingrandimento

Vorderseite Rhodium beschichtet
front side rhodium plated
devant revêtu de rhodium
parte anterior con revestimiento de rodio
lato anteriore con rivestimento in rodio

mit konischem Gewindeauslauf
with conical end of thread
avec extrémité fileté conique
con terminal cónica de rosca
con filettatura a estremità conica

82.704.20	20 mm	N° 3	82.705.20	20 mm	N° 3	82.706.20	20 mm	N° 3
82.704.22	22 mm	N° 4	82.705.22	22 mm	N° 4	82.706.22	22 mm	N° 4
82.704.24	24 mm	N° 5	82.705.24	24 mm	N° 5	82.706.24	24 mm	N° 5

konisches Gewinde
conical thread
filetage conique
rosca cónica
filettatura conico

metrisches Gewinde
metric thread
filetage métrique
rosca métrica
filettatura metrica

leichtes Modell
light model
modèle léger
módulo modelo ligero
modello leggero

leichtes Modell
light model
modèle léger
módulo modelo ligero
modello leggero



1/1

82.721.14 13,5 cm|5 1/4" ø 7 mm



1/1

82.721.04 13,5 cm|5 1/4" ø 7 mm



1/1

82.726.01 12 cm|4 3/4" ø 7 mm

metrisches Gewinde
metric thread
filetage métrique
rosca métrica
filettatura metrica



82.728.00	12 cm 4 3/4"	82.728.01	12 cm 4 3/4"	82.730.01	12 cm 4 3/4"	82.731.00	12 cm 4 3/4"
ø 5 mm		ø 5 mm		ø 5 mm		ø 5 mm	

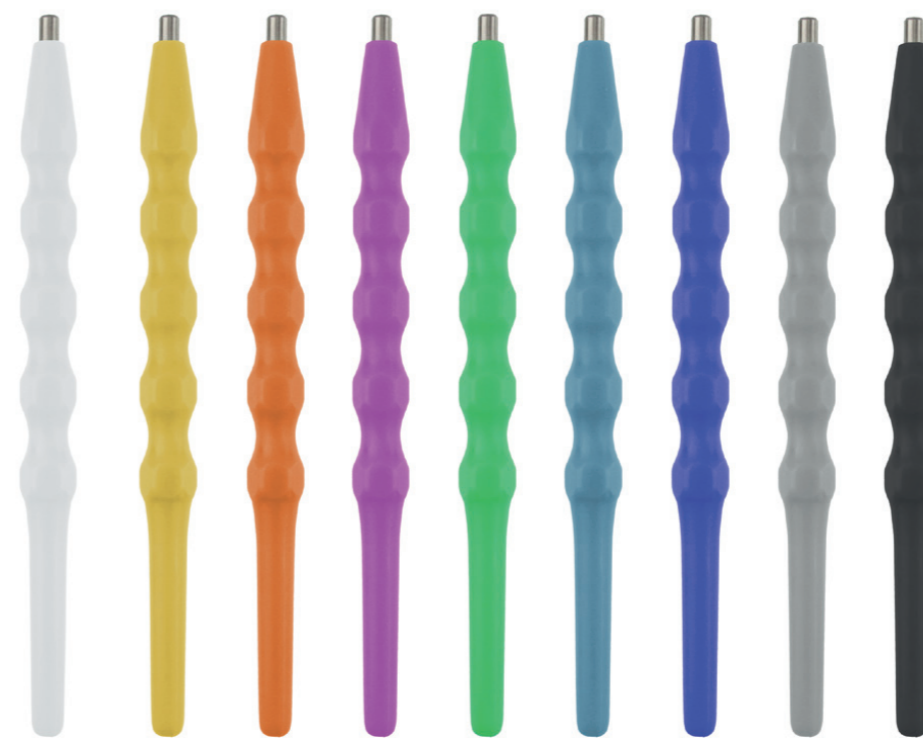

82.738.01	13,5 cm 5 1/4"	1
82.738.02	13,5 cm 5 1/4"	2
82.738.03	13,5 cm 5 1/4"	3
82.738.04	13,5 cm 5 1/4"	4
82.738.05	13,5 cm 5 1/4"	5
82.738.06	13,5 cm 5 1/4"	6
82.738.07	13,5 cm 5 1/4"	7
82.738.08	13,5 cm 5 1/4"	8
82.738.09	13,5 cm 5 1/4"	9

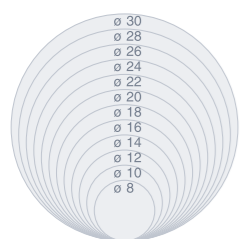

52.270.08	8 mm	N° 00
52.270.10	10 mm	N° 0
52.270.12	12 mm	N° 1
52.270.14	14 mm	N° 2
52.270.16	16 mm	N° 3
52.270.18	18 mm	N° 4
52.270.20	20 mm	N° 5
52.270.22	22 mm	N° 6
52.270.24	24 mm	N° 7
52.270.26	26 mm	N° 8
52.270.28	28 mm	N° 9
52.270.30	30 mm	N° 10

52.272.08	8 mm	N° 00
52.272.10	10 mm	N° 0
52.272.12	12 mm	N° 1
52.272.14	14 mm	N° 2
52.272.16	16 mm	N° 3
52.272.18	18 mm	N° 4
52.272.20	20 mm	N° 5
52.272.22	22 mm	N° 6
52.272.24	24 mm	N° 7
52.272.26	26 mm	N° 8
52.272.28	28 mm	N° 9
52.272.30	30 mm	N° 10

52.276.10

16

PARODONTOLOGIE
PERIODONTOLOGY
PARODONTOLOGIE
PERIODONCIA
PARODONTOLOGIA



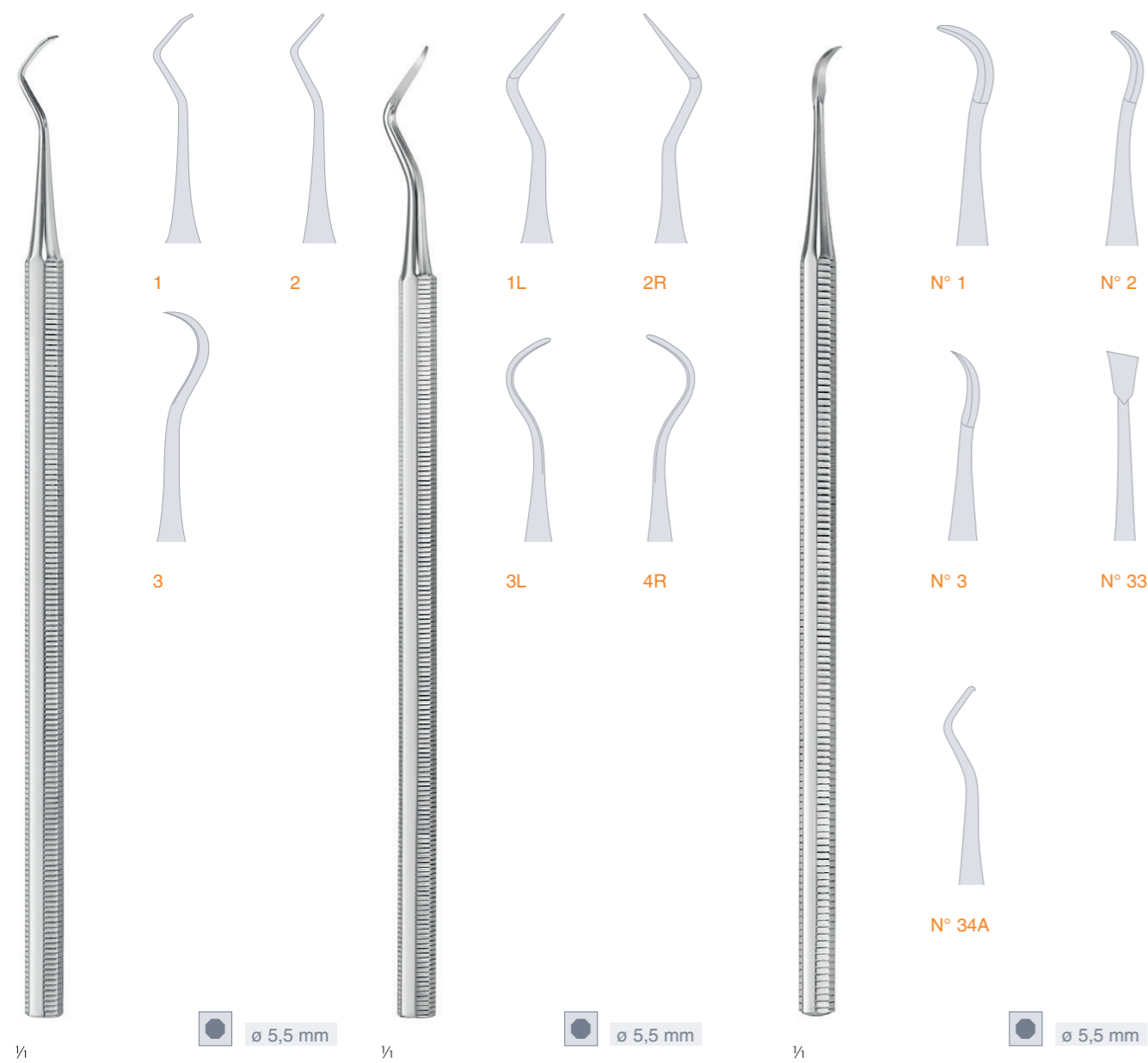

- 83.230.01 1 WILLIGER
- 83.231.01 2 WILLIGER
- 83.237.00 3 BLACK

MUEHLEMANN

- 83.239.01 1L
- 83.239.02 2R
- 83.243.01 3L
- 83.243.02 4R

- 83.245.01 N° 1
- 83.245.02 N° 2
- 83.245.03 N° 3
- 83.245.33 N° 33
- 83.245.38 N° 34A



- 83.250.01 N° 1
- 83.250.02 N° 2
- 83.250.03 N° 3
- 83.250.04 N° 4
- 83.250.05 N° 5
- 83.250.06 N° 6
- 83.250.07 N° 7
- 83.250.08 N° 8



83.250.00

Satz aus 8 Stück
set of 8 pieces
set de 8 pièces
set de 8 piezas
set di 8 pezzi

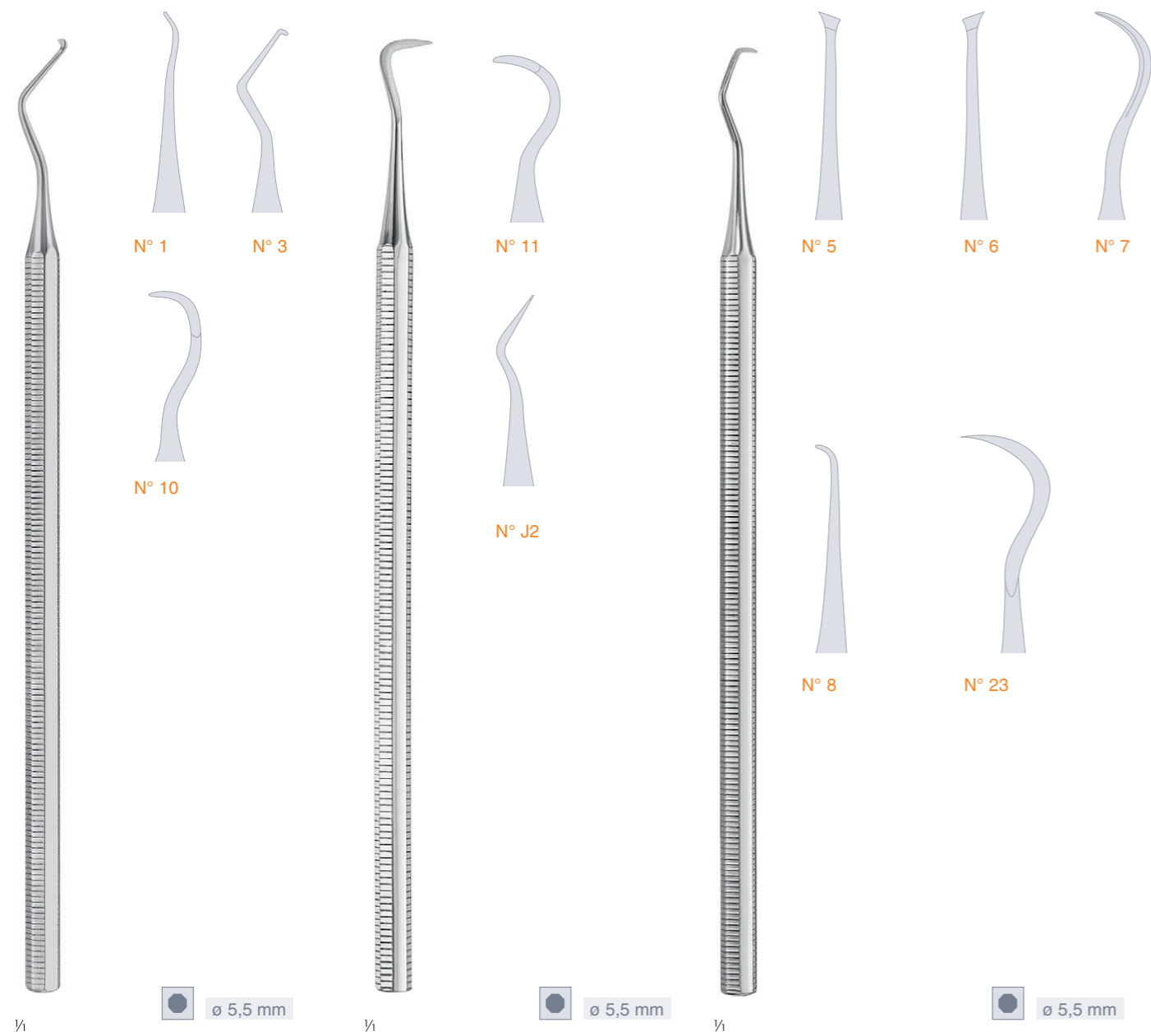

83.277.01 MCCALL N° 1
83.277.03 MCCALL N° 3
83.277.10 MCCALL N° 10

83.251.11 DARBY-PERRY N° 11
83.271.02 JACQUETTE N° J2

83.301.05 SCHARMANN N° 5
83.301.06 SCHARMANN N° 6
83.301.07 SCHARMANN N° 7
83.301.08 SCHARMANN N° 8
83.307.23 SICHEL N° 23

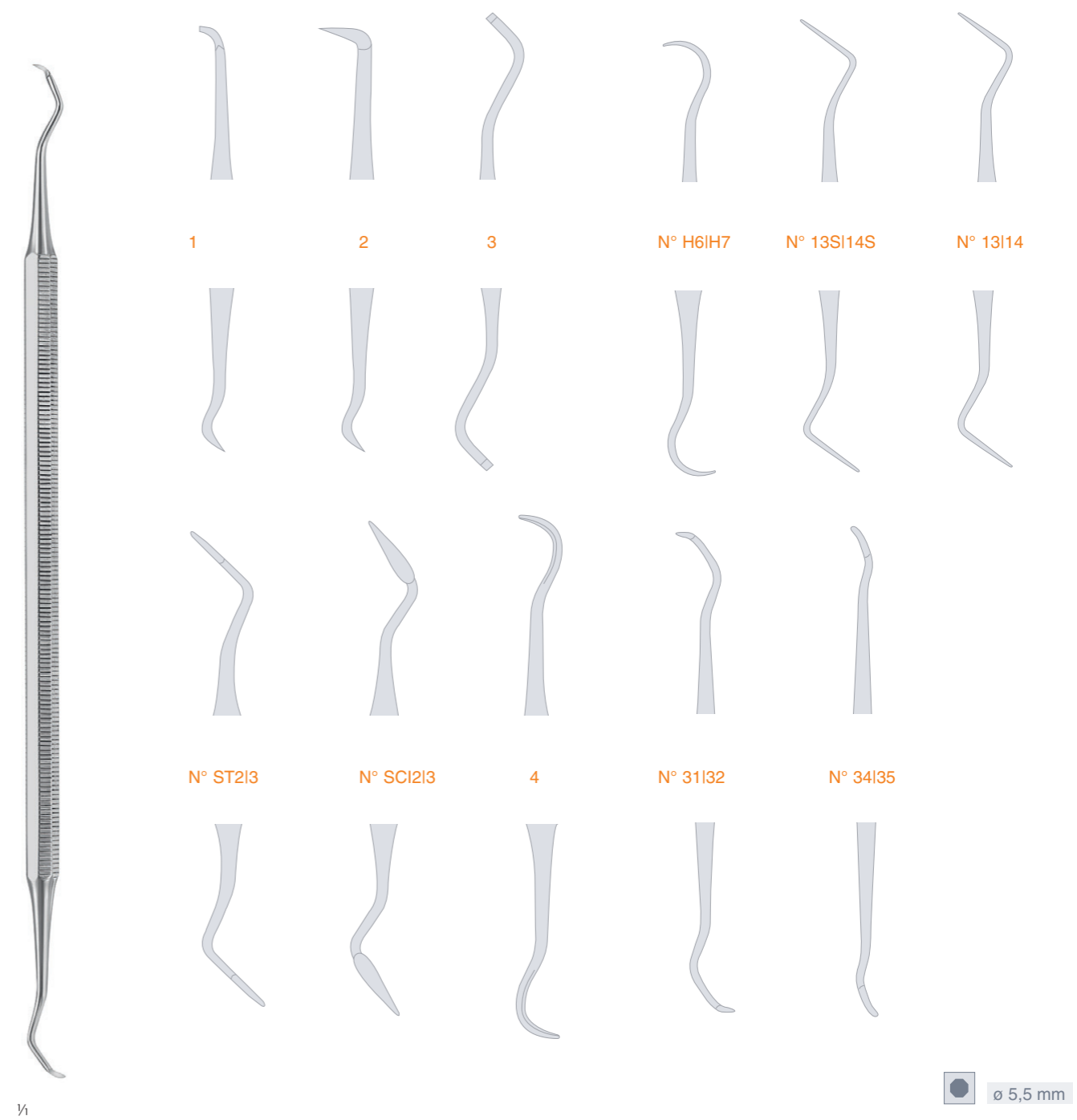

83.282.02 CUMINE 1
83.283.02 MITCHELL 2
83.292.29 3
83.293.01 TAYLOR N° ST2I3
83.293.02 N° SCI2I3
83.296.04 YOUNGER-GOOD 4

83.312.07 HYGIENIST N° H6IH7
83.312.13 MCCALL N° 13SI14S
83.312.14 MCCALL N° 13I14
83.312.02 JACQUETTE N° 31I32
83.312.03 JACQUETTE N° 34I35

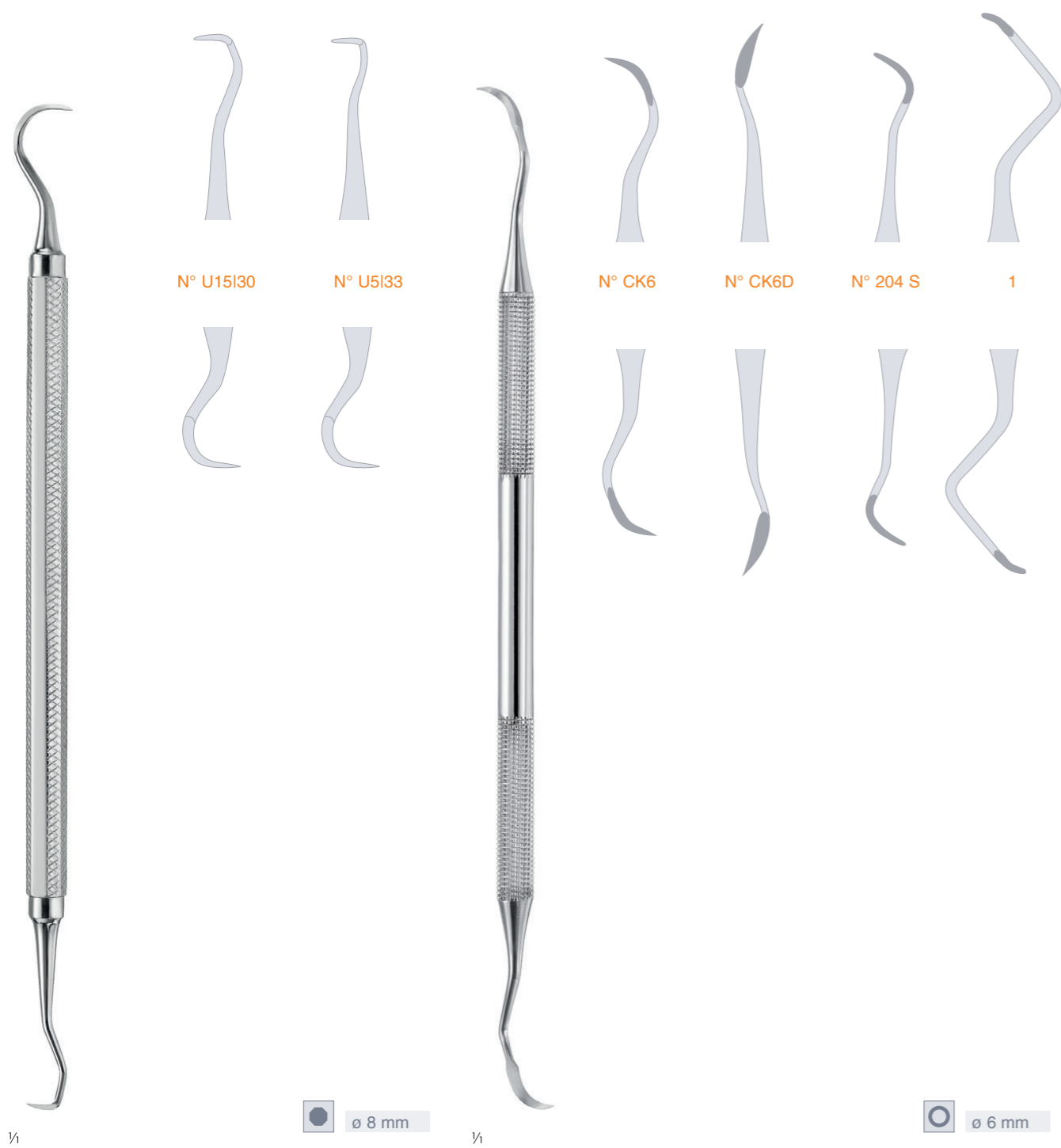

- | | | |
|-----------|------------------|-----------|
| 83.308.30 | TOWNER-JACQUETTE | N° U15130 |
| 83.308.33 | TOWNER-JACQUETTE | N° U5133 |

- | | | |
|-----------|--------------|---------|
| 83.328.06 | CRANE-KAPLAN | N° CK6 |
| 83.328.61 | CRANE-KAPLAN | N° CK6D |
| 83.329.24 | | N° 204S |
| 83.330.00 | PRICHARD | 1 |

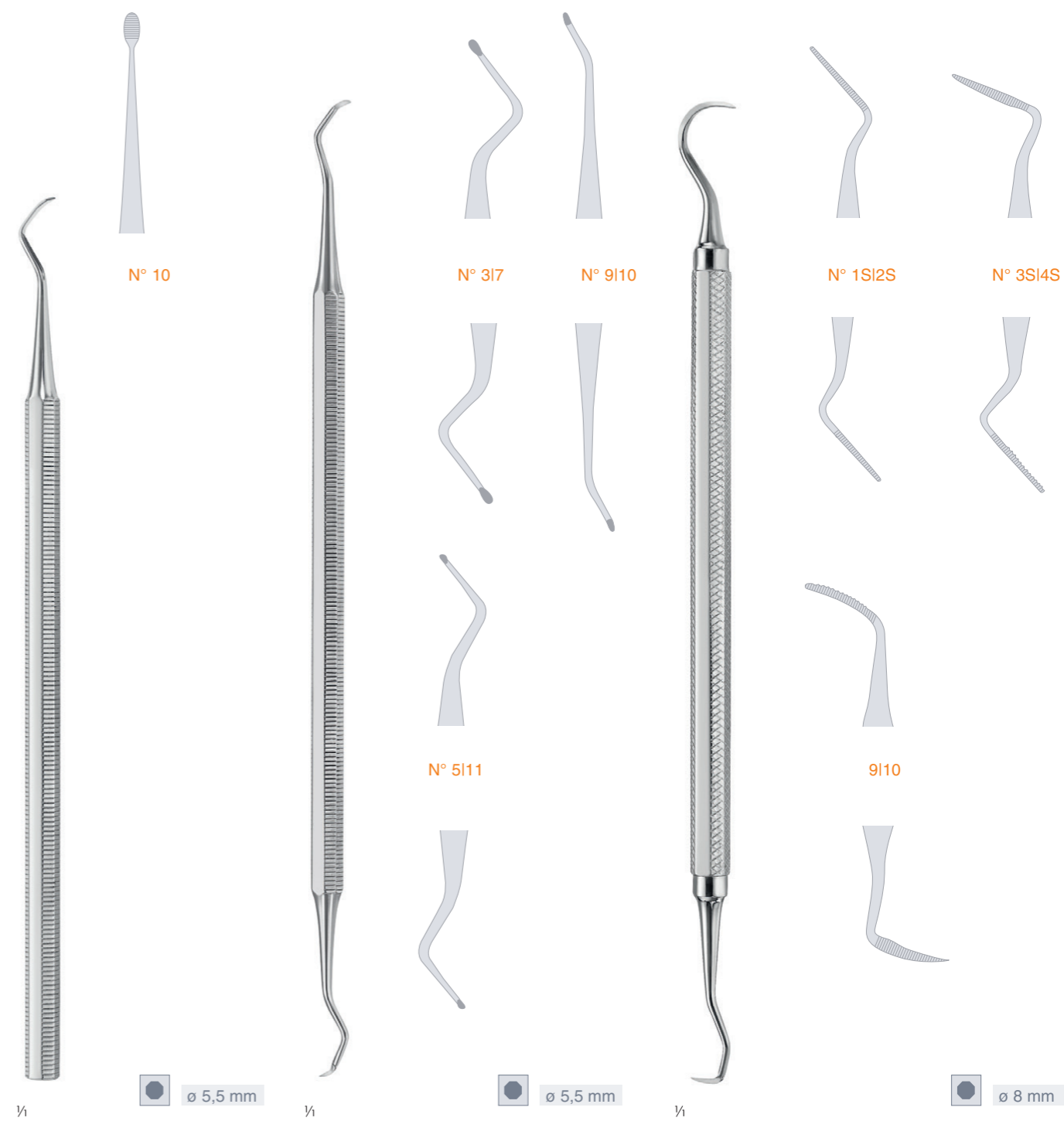

- | | |
|-----------|---------------|
| 83.317.10 | BUNTING N° 10 |
|-----------|---------------|

- | | | |
|-----------|------------|---------|
| 83.315.07 | HIRSCHFELD | N° 317 |
| 83.315.10 | HIRSCHFELD | N° 9110 |
| 83.315.11 | HIRSCHFELD | N° 5111 |

- | | | |
|-----------|----------|----------|
| 83.316.02 | SUGARMAN | N° 1S12S |
| 83.316.03 | SUGARMAN | N° 3S14S |
| 83.316.19 | SCHLUGER | 9110 |



1/4

83.290.02	COLUMBIA	N° 2Ri2L
83.290.04	COLUMBIA	N° 4Ri4L
83.290.14	COLUMBIA	N° 13i14
83.291.08	YOUNGER-GOOD	N° 7i8
83.295.02	LANGER	N° 1i2
83.295.04	LANGER	N° 3i4
83.293.06	CRANE-KAPLAN	N° CK 6

ø 6 mm



1/4

GOLDMAN-FOX

83.326.01	N° 1	83.326.07	N° 7
83.326.02	N° 2	83.326.08	N° 8
83.326.03	N° 3	83.326.09	N° 9
83.326.04	N° 4	83.326.10	N° 10
83.326.05	N° 5	83.326.11	N° 11
83.326.06	N° 6	83.326.21	N° 21

ø 6 mm



N° 112 N° 314 N° 516 N° 718 N° 9110



N° 11112 N° 12113 N° 13114 N° 15116



∅ 6 mm



1/1

GRACEY

83.327.02	N° 112	83.327.12	N° 11112
83.327.04	N° 314	83.327.13	N° 12113
83.327.06	N° 516	83.327.14	N° 13114
83.327.08	N° 718	83.327.16	N° 15116
83.327.10	N° 9110		



N° 112 N° 314 N° 516 N° 718 N° 9110



N° 11112 N° 12113 N° 13114 N° 15116

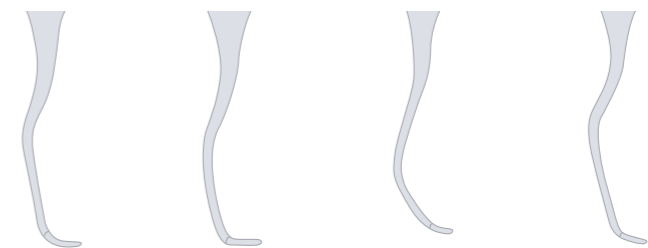

∅ 9,5 mm



1/1

GRACEY

83.327.02H1	N° 112	83.327.12H1	N° 11112
83.327.04H1	N° 314	83.327.13H1	N° 12113
83.327.06H1	N° 516	83.327.14H1	N° 13114
83.327.08H1	N° 718	83.327.16H1	N° 15116
83.327.10H1	N° 9110		



1/4
 KIRKLAND
 83.331.15 N° 15

1/4
 KIRKLAND
 83.331.16 N° 16

1/4
 KIRKLAND
 83.332.16 N° 15/16

ø 6 mm

1/4
 ORBAN
 83.339.02 N° 2

83.340.22 N° 22

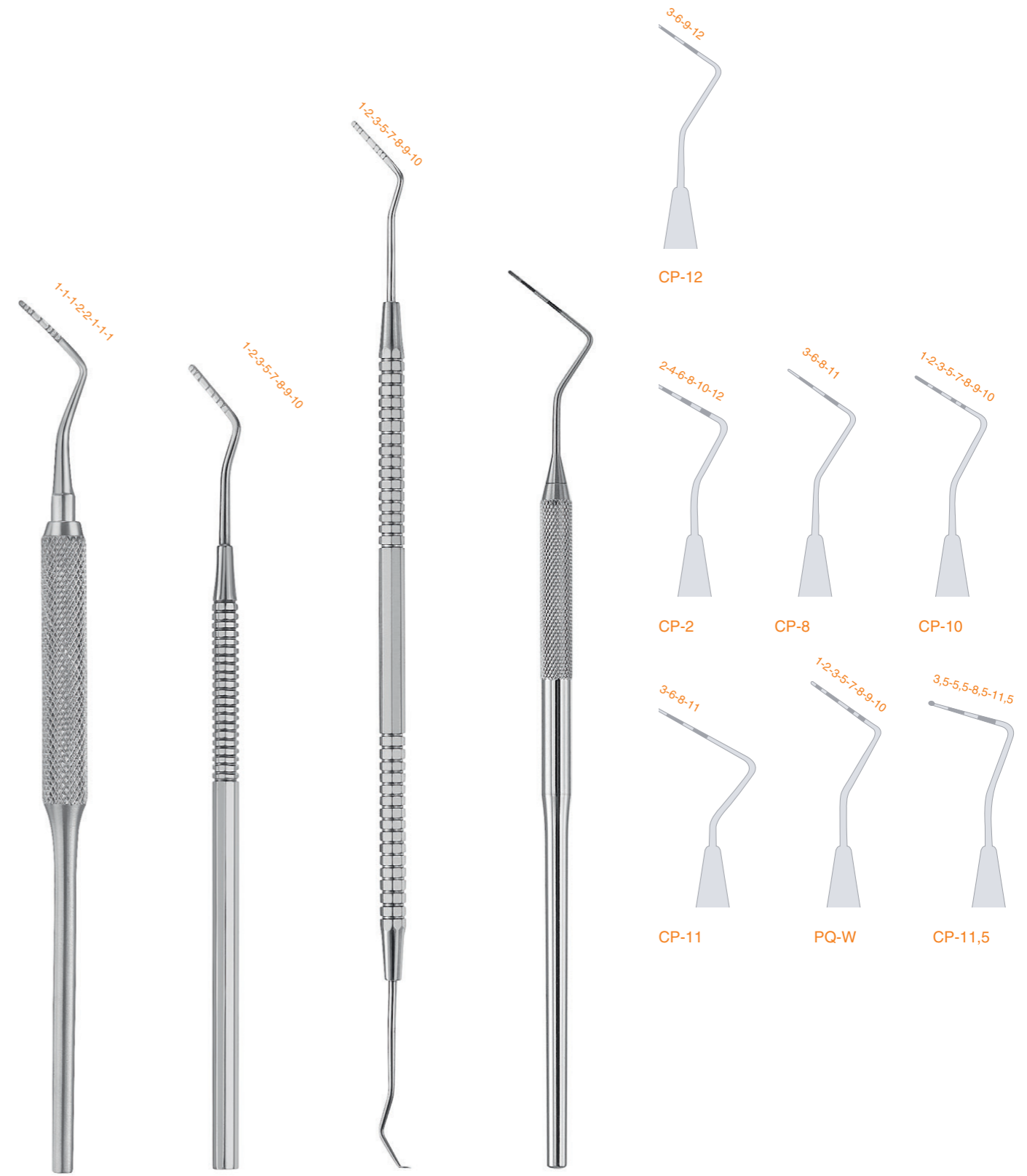

1/4
 83.344.01

1/4
 83.345.01

1/4
 83.346.01

1/4
 83.352.12 CP-12
 83.352.02 CP-2
 83.352.08 CP-8
 83.352.10 CP-10

83.352.11 N° 11 CP-11
 83.354.00 WILLIAMS PQ-W
 83.355.00 WHO CP-11,5

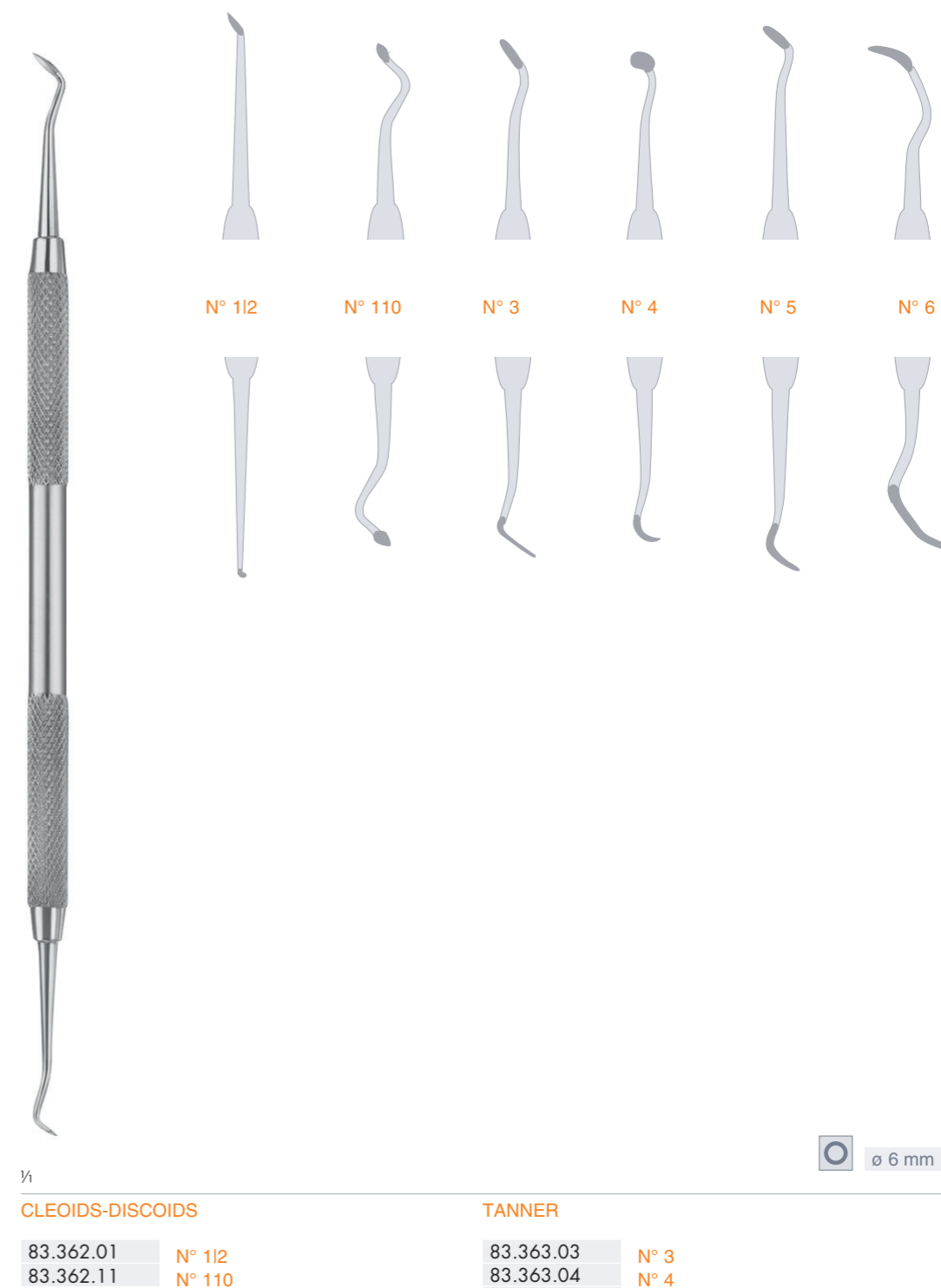
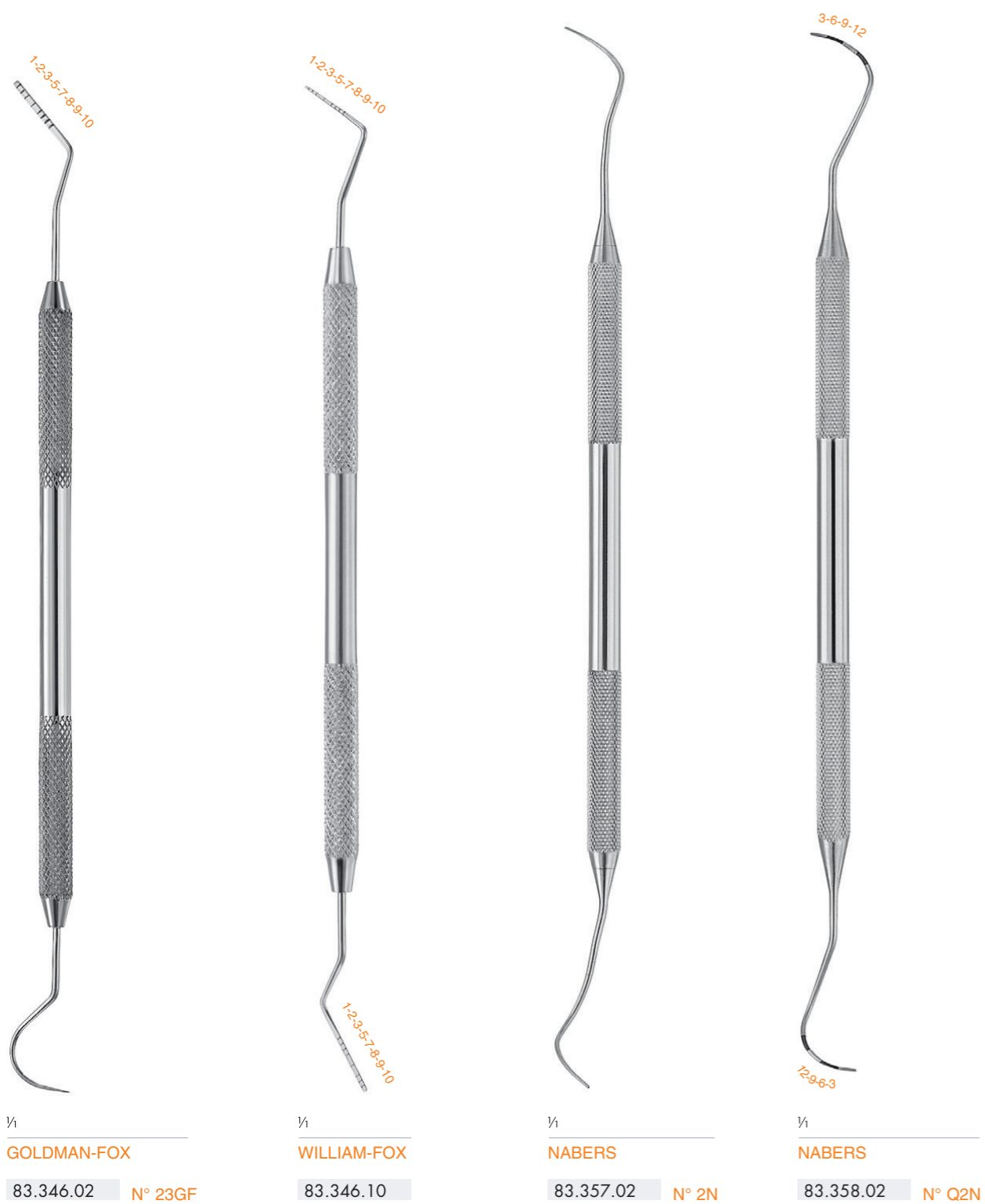

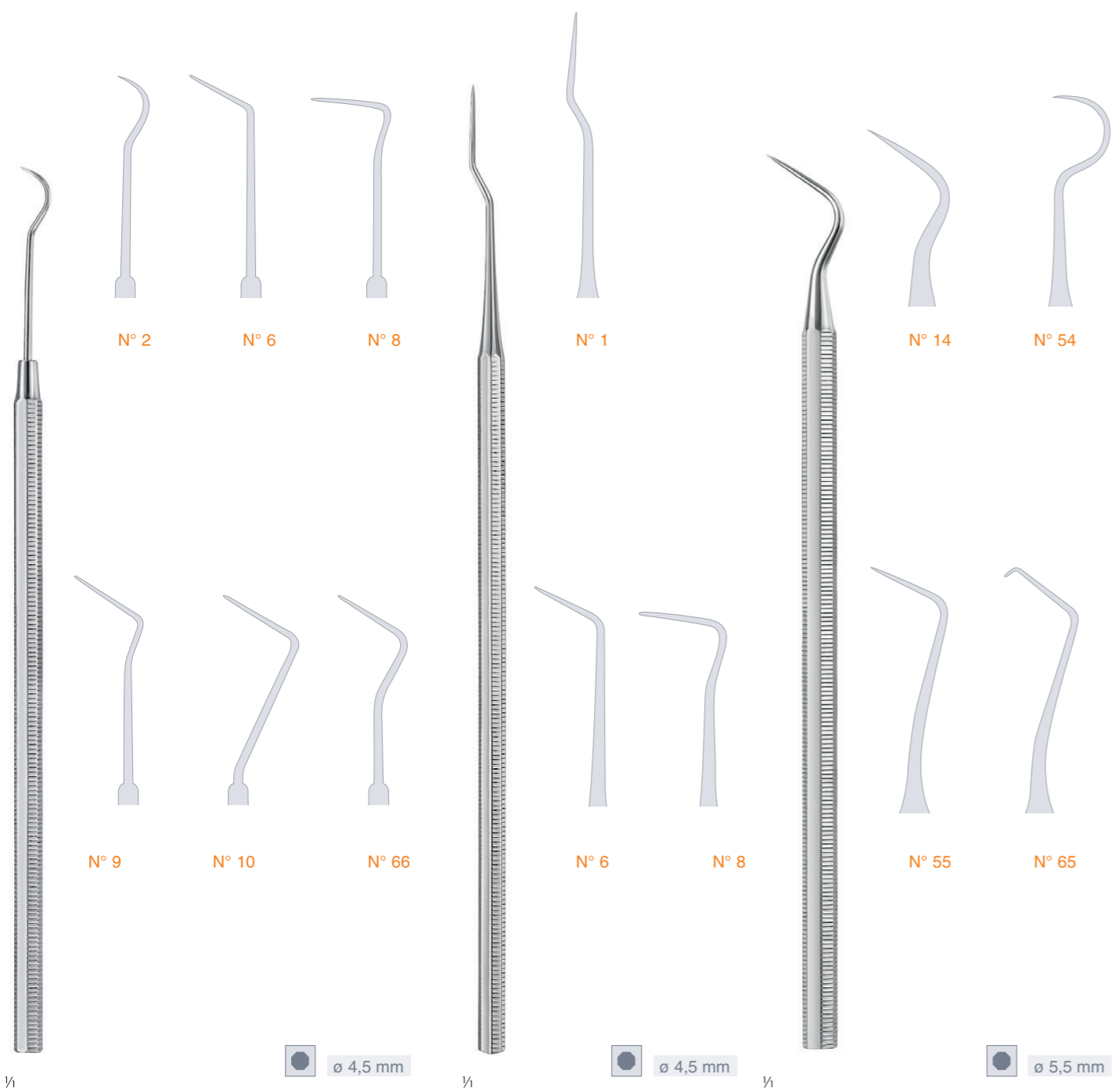

- 83.391.02 N° 2
- 83.391.06 N° 6
- 83.391.08 N° 8
- 83.391.09 N° 9
- 83.391.10 N° 10
- 83.391.66 N° 66

- 83.394.01 N° 1
- 83.394.06 N° 6
- 83.394.08 N° 8

- 83.397.14 N° 14
- 83.397.54 N° 54
- 83.397.55 N° 55
- 83.397.65 N° 65



WHITE

- 83.401.01 N° 1
- 83.401.02 N° 2
- 83.401.03 N° 3
- 83.401.05 N° 5
- 83.401.06 N° 6
- 83.401.07 N° 7
- 83.401.08 N° 8
- 83.401.23 N° 23
- 83.401.42 N° 42

- 83.405.03 N° 3
- 83.405.23 SHEPHERD N° 23
- 83.405.54 N° 54
- 83.405.06 N° 6A

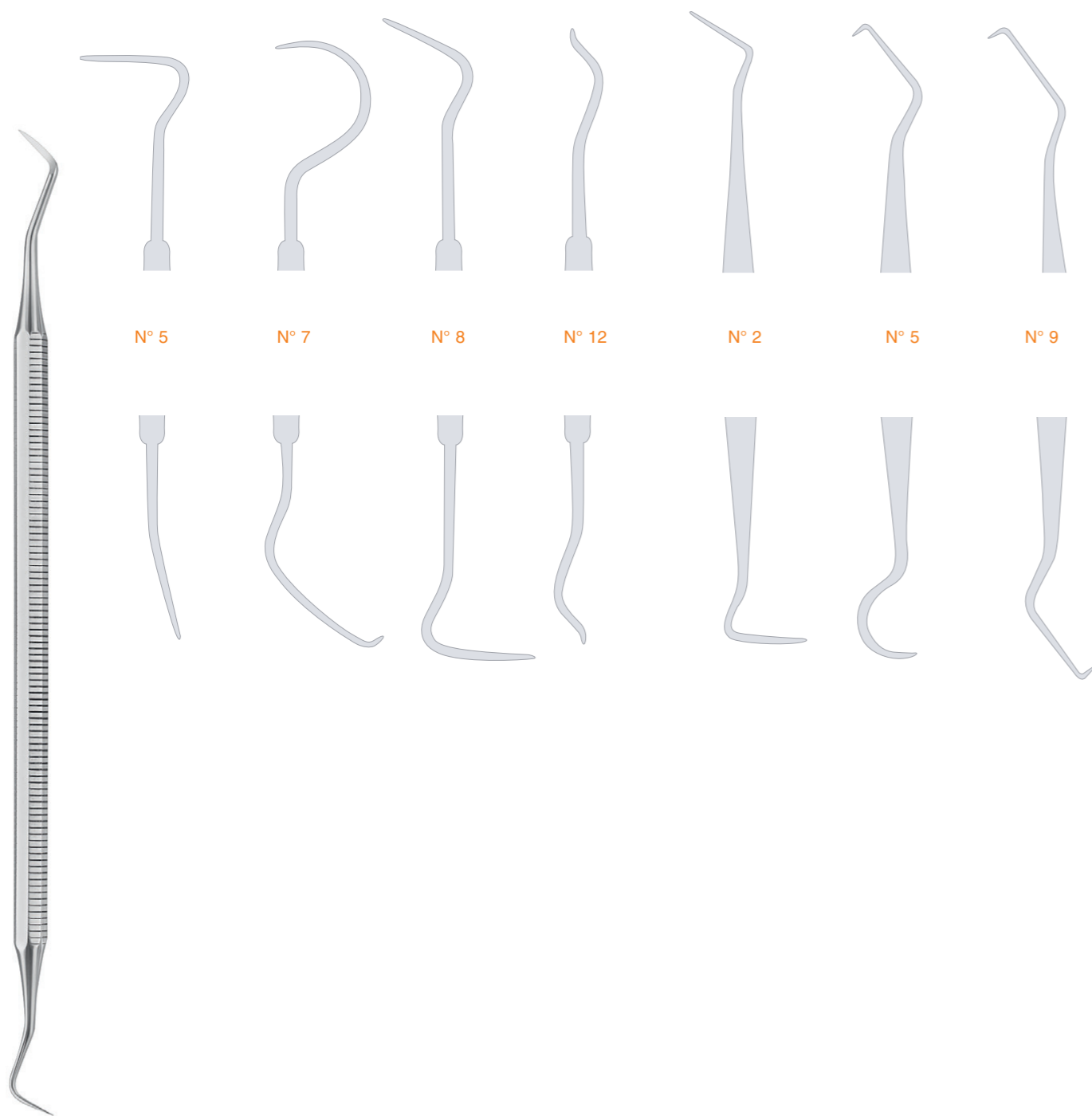

ø 5,5 mm

- 83.392.05 N° 5
- 83.392.07 N° 7
- 83.392.08 N° 8
- 83.392.12 WESTON N° 12

- 83.421.02 N° 2
- 83.421.05 N° 5
- 83.421.09 N° 9

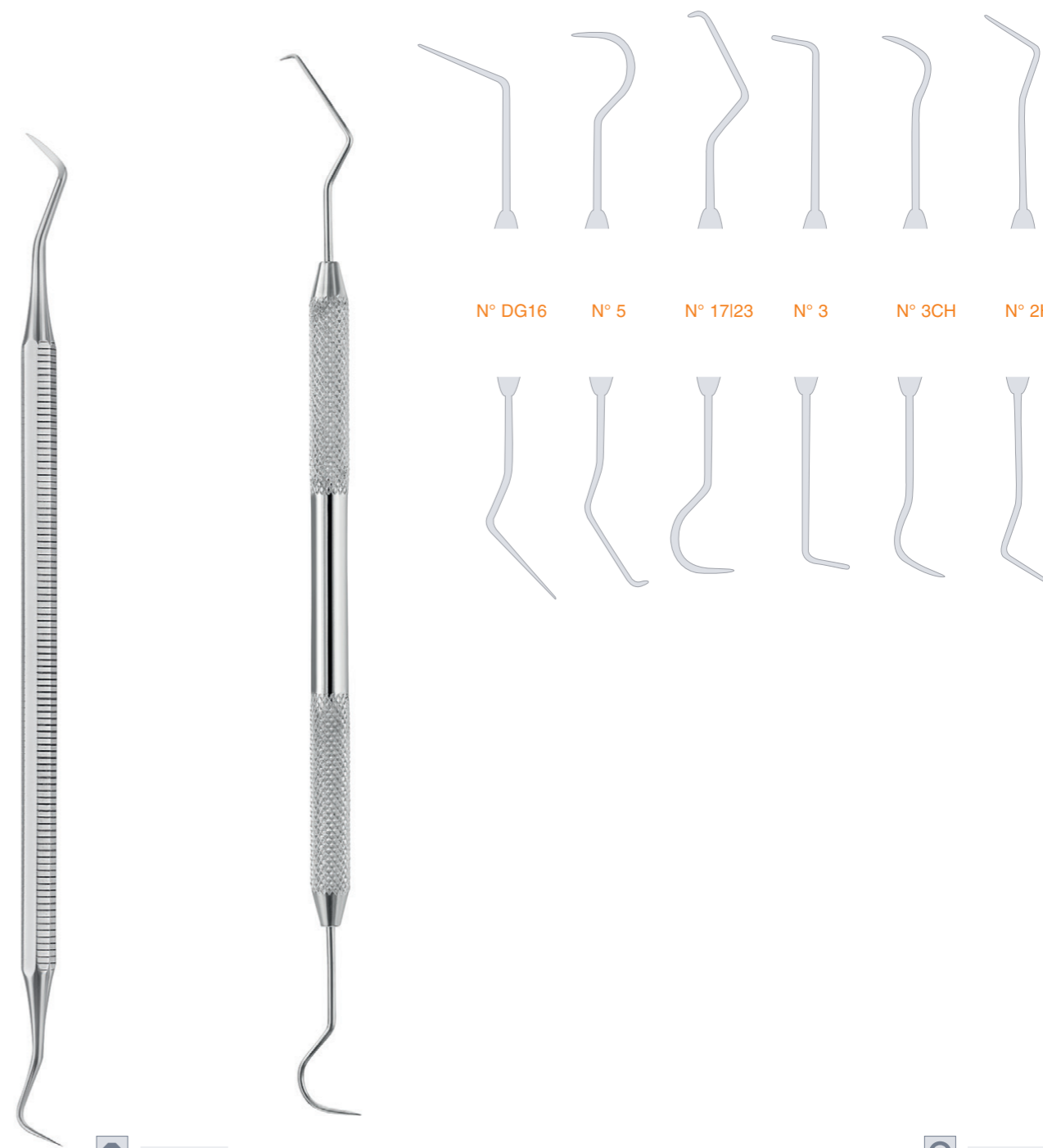

ø 6 mm

- LANGE
- 83.399.01 N° 1

- 83.439.16 N° DG16
- 83.440.05 N° 5
- 83.441.17 WILKINS-TUFTS N° 17123
- 83.442.03 N° 3
- 83.443.03 N° 3CH
- 83.444.02 N° 2H

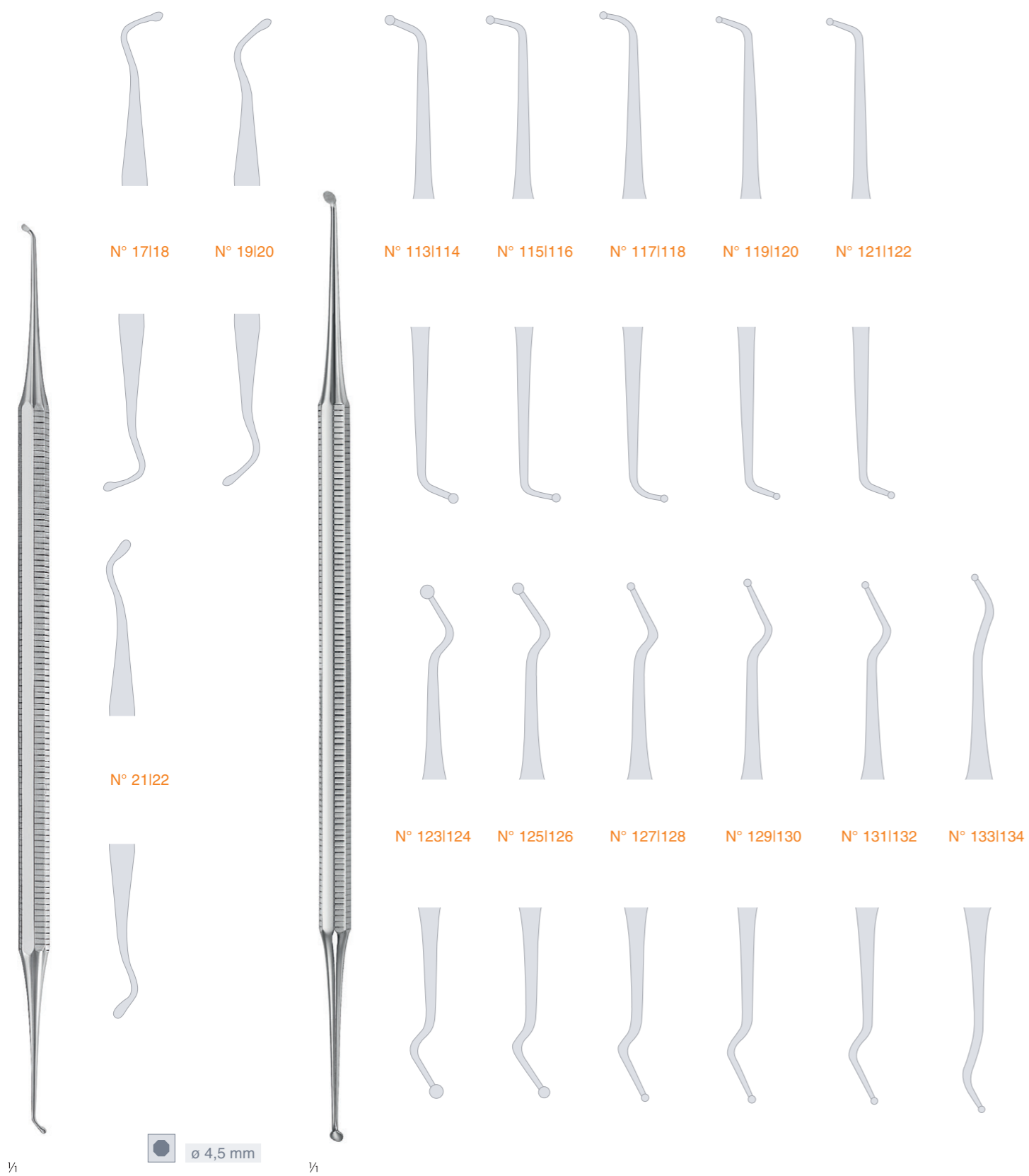

DARBY-PERRY

83.446.17 N° 17118
83.446.19 N° 19120
83.446.21 N° 21122

83.452.05	N° 113114	83.452.10	N° 1231124	83.452.15	N° 1331134
83.452.06	N° 115116	83.452.11	N° 1251126		
83.452.07	N° 117118	83.452.12	N° 1271128		
83.452.08	N° 119120	83.452.13	N° 1291130		
83.452.09	N° 121122	83.452.14	N° 1311132		

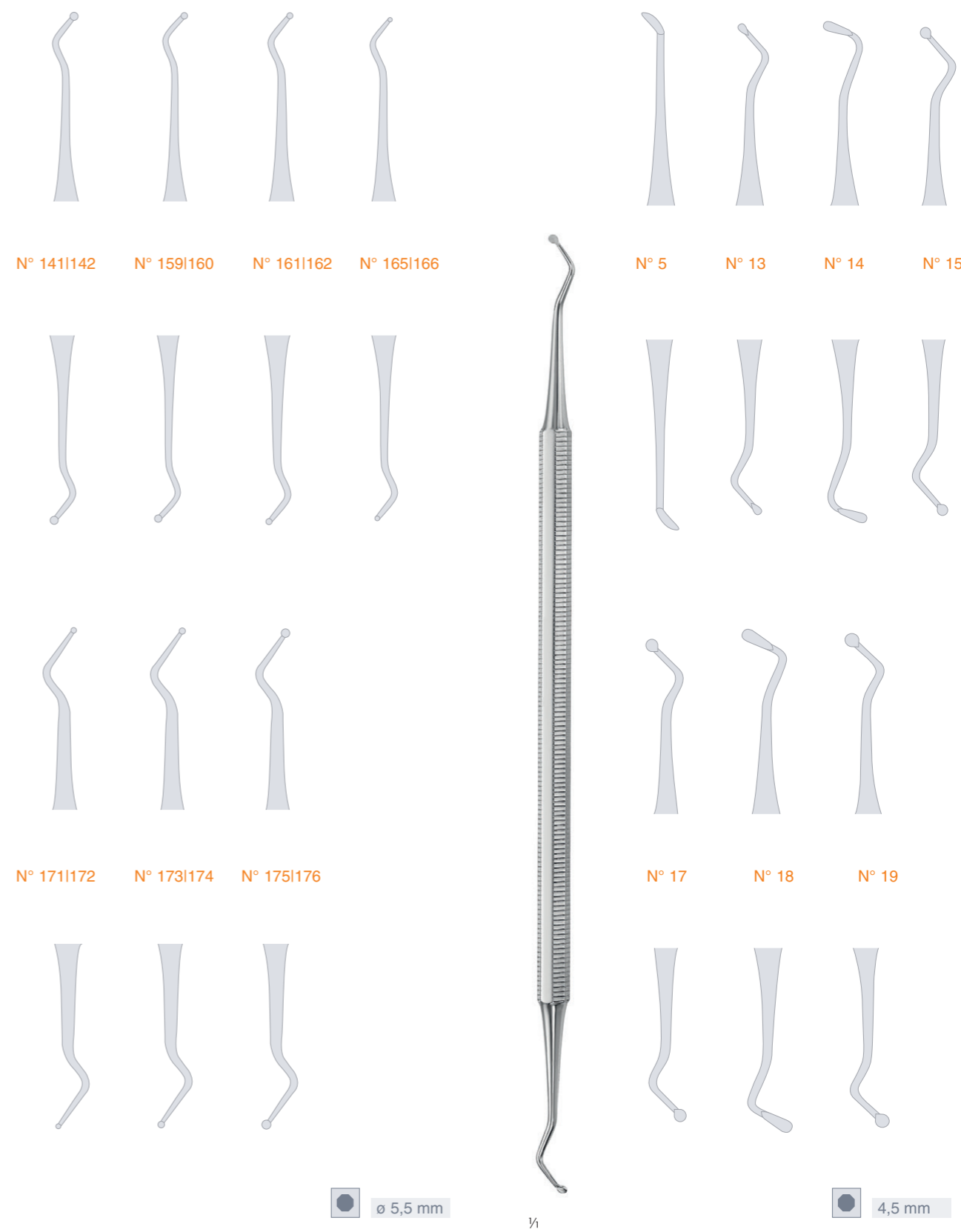

WHITE

83.481.05 N° 5
83.481.13 N° 13
83.481.14 N° 14
83.481.15 N° 15
83.481.17 N° 17
83.481.18 N° 18
83.481.19 N° 19

83.462.41	N° 1411142	83.462.73	N° 1731174
83.462.59	N° 1591160	83.462.75	N° 1751176
83.462.61	N° 1611162		
83.462.65	N° 1651166		
83.462.71	N° 1711172		



N° 5 N° 13 N° 14

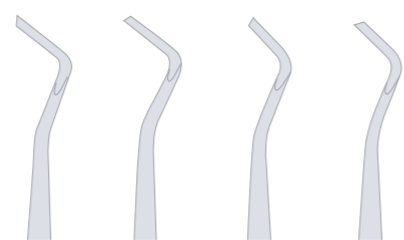

N° 26 N° 27 N° 28 N° 29

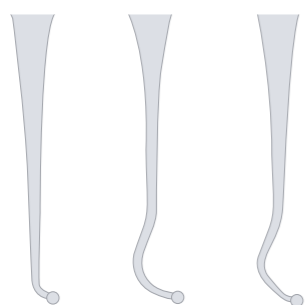

N° 17 N° 35



ø 6 mm

BLACK

- 83.485.05 N° 5 hohler Griff
- 83.485.13 N° 13 hollow handle
- 83.485.14 N° 14 manche creux
- 83.485.17 N° 17 mango hueco
- 83.485.35 N° 35 manico cavo

- 83.494.26 N° 26 hohler Griff
- 83.494.27 N° 27 hollow handle
- 83.494.28 N° 28 manche creux
- 83.494.29 N° 29 mango hueco
- 83.494.29 N° 29 manico cavo

0,40 mm 0,55 mm 0,75 mm

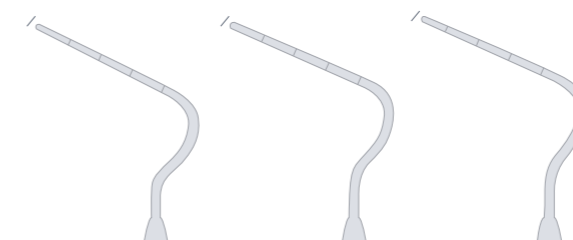

N° 8 N° 9 N° 10



1,05 mm 1,30 mm

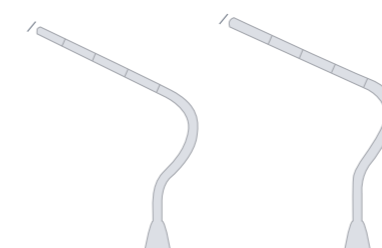

N° 11 N° 12

1/4

- 83.500.08 N° 8
- 83.500.09 N° 9
- 83.500.10 N° 10
- 83.500.11 N° 11
- 83.500.12 N° 12



LUKS

- 83.501.01 N° L1

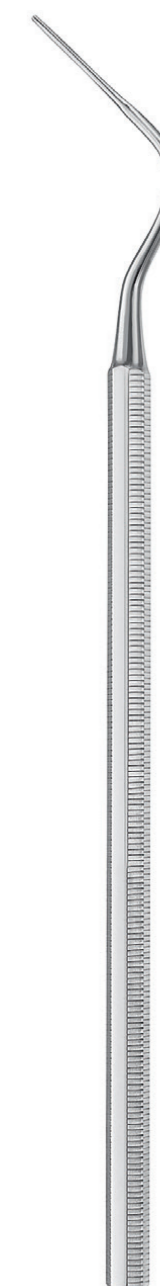

THUERRIEGEL

- 83.511.08

ø 5,5 mm

1/4



1/1 83.502.25 N° 1S
 1/1 83.502.60 N° D11
 1/1 83.504.13 N° 113



Nervkanalzangen
 root canal forceps
 pinces pour canal
 pinza para canales
 pinze per canalari

1/1 83.525.13 13 cm/5"



1/1 83.524.13 13 cm/5"

17

FÜLLUNGSTRUMENTE

- FILLING INSTRUMENTS
- INSTRUMENTS DE PLOMBAGE
- INSTRUMENTOS PARA OBTURACIONES
- OTTURATORI



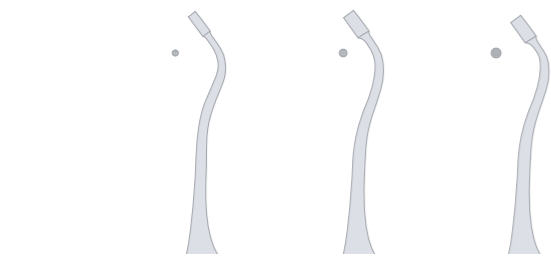

N° 00 N° 10 N° 11

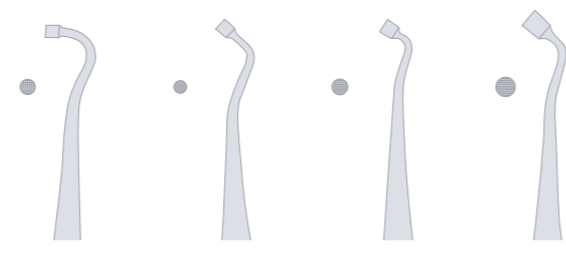

N° 1 N° 2 N° 3 N° 4

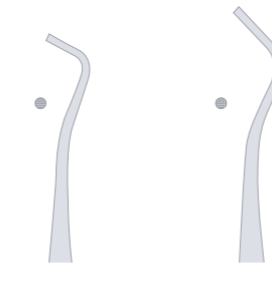

1 2

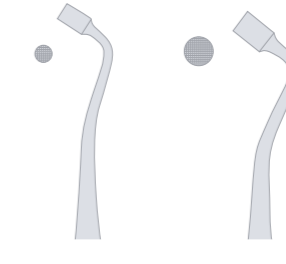

N° 112 N° 314

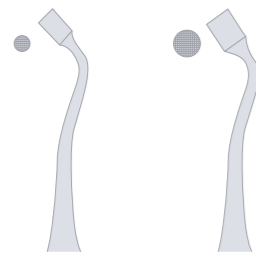
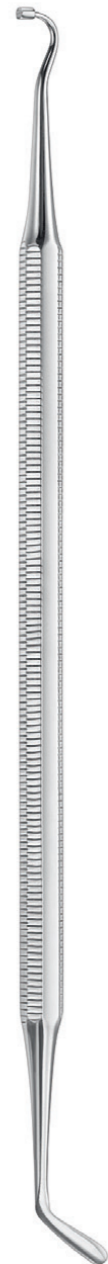

N° 12 N° 13

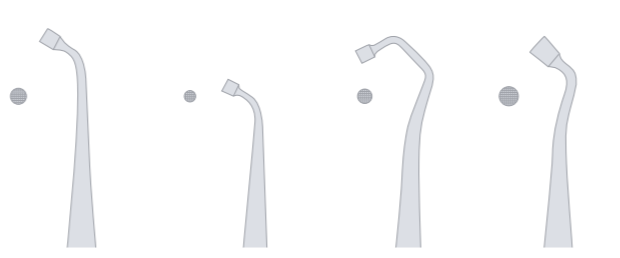

N° 5 N° 5A N° 6 N° 7



3

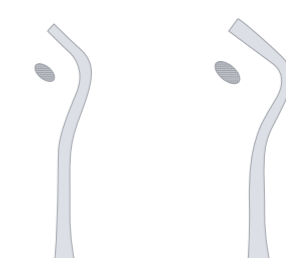

N° 516 N° 718

1/4  ø 5,5 mm

1/4  ø 5,5 mm

 ø 5,5 mm

1/4  ø 5,5 mm

1/4  ø 5,5 mm

BLACK

- 84.151.10 N° 1
- 84.151.20 N° 2
- 84.151.30 N° 3
- 84.151.40 N° 4
- 84.151.50 N° 5
- 84.151.51 N° 5A
- 84.151.60 N° 6
- 84.151.70 N° 7

- 84.141.00 N° 00
- 84.141.10 N° 10
- 84.141.11 N° 11
- 84.141.12 N° 12
- 84.141.13 N° 13

HAUBEIL

- 84.163.00 ELLIOT 1
- 84.165.00 EAMES 2
- 84.167.00 HOLLENBACK 3

- 84.171.12 N° 112
- 84.171.34 N° 314
- 84.171.56 N° 516
- 84.171.78 N° 718

84.152.07

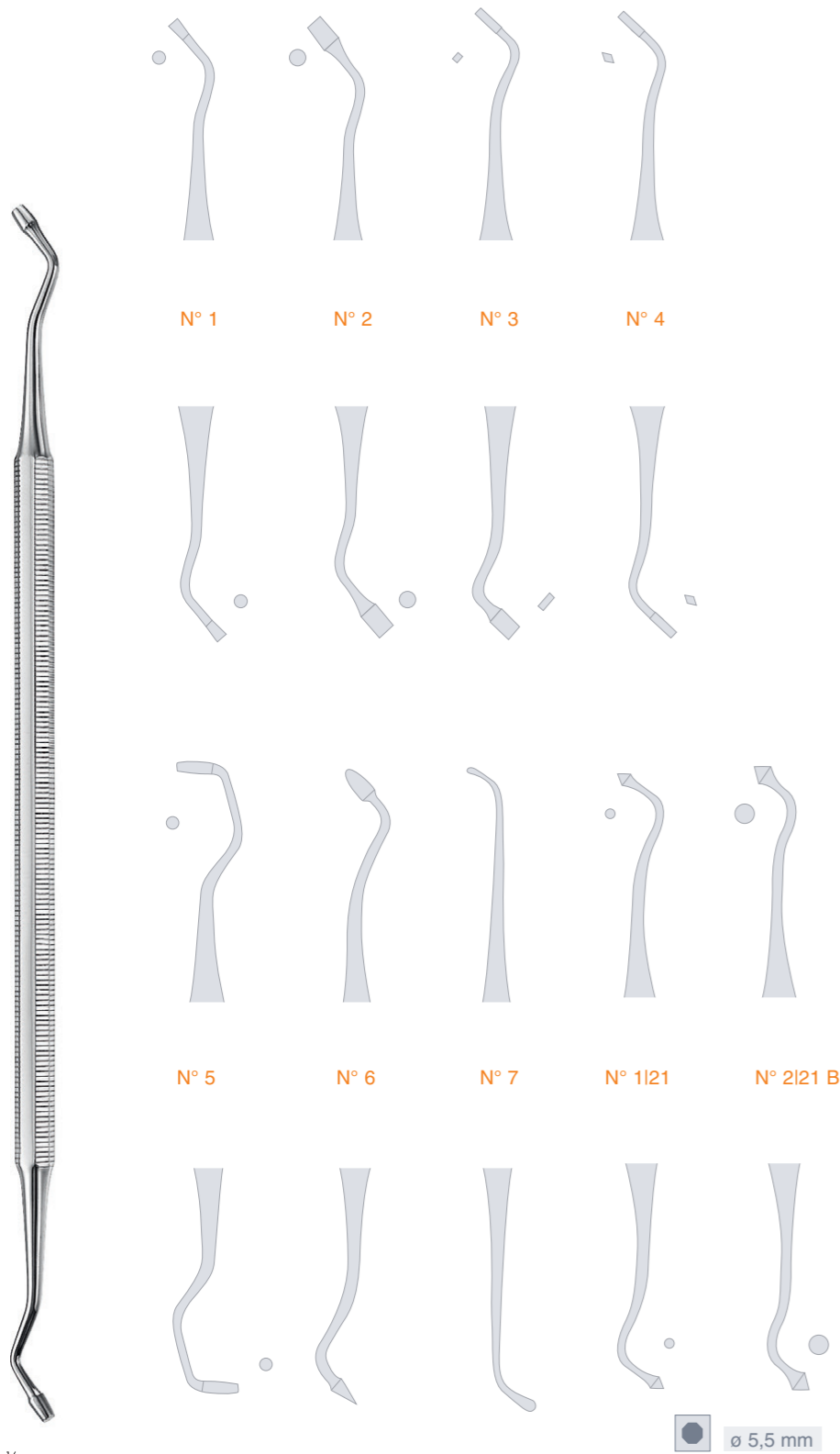

Plomben- und Verschlussheber
 instrument for lifting and loosening temporary fillings
 instrument pour enlever les plombages temporaires
 instrumentos para quitar obturaciones temporales
 strumenti per estrazione di otturazioni provvisorie

1/1
HOLLENBACK **WESTCOTT**

- 84.175.01 N° 1
- 84.175.02 N° 2
- 84.175.03 N° 3
- 84.175.04 N° 4
- 84.175.05 N° 5
- 84.175.06 N° 6
- 84.175.07 N° 7

- 84.177.01 N° 1121
- 84.177.02 N° 2121 B

84.358.00

Amalgampistolen
 amalgam carriers
 porte-amalgames
 porta-amalgamas
 pistole per amalgama

Amalgamträger
 amalgam carriers
 porte-amalgames
 porta-amalgamas
 pistole per amalgama



Plastikspitze
 plastic tip
 pointe en plastique
 punta de plástico
 punta in plastica

84.185.01



84.185.02



Metallspitze
 metal tip
 pointe en métal
 punta de metal
 punta in metallo

84.187.01



84.187.02



1/2

IVORY

84.206.17
 17 cm | 6 3/4"

1/2

IVORY

84.206.21
 21 cm | 8 1/4"

POLIERINSTRUMENTE

BURNISHERS
BRUNISSOIRS
BRUÑIDORES
BRUNITORI



N° 1 N° 2 N° 3 N° 5



N° 25 N° 26 N° 27

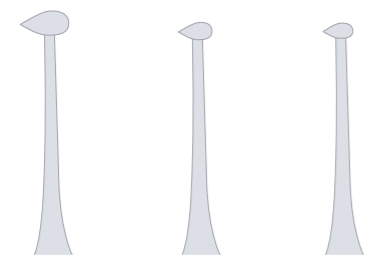

N° 28 N° 29 N° 31

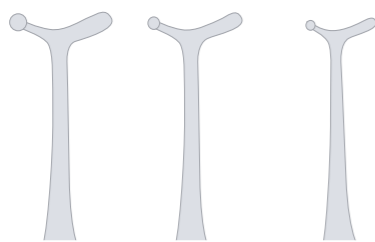

N° 32 N° 33 N° 34



N° 18 N° 21 N° 21B



N° 26|27S N° 27|29

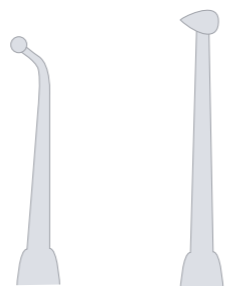

1/4

WHITE

84.231.01	N° 1	84.231.26	N° 26
84.231.02	N° 2	84.231.27	N° 27
84.231.03	N° 3	84.231.28	N° 28
84.231.05	N° 5	84.231.29	N° 29
84.231.25	N° 25	84.231.31	N° 31
		84.231.32	N° 32
		84.231.33	N° 33
		84.231.34	N° 34

84.233.18	BALL	N° 18
84.233.21	ACORN	N° 21
84.233.22	ACORN	N° 21B
84.233.26	BALL	N° 26 27S
84.233.27	BALL	N° 27 29

INSTRUMENTE FÜR PLASTISCHE FÜLLUNGEN

PLASTIC FILLING INSTRUMENTS
INSTRUMENTS POUR PLOMBAGES PLASTIQUES
INSTRUMENTOS PARA OBTURACIONES PLÁSTICAS
STRUMENTI PER OTTURAZIONE PLASTICHE

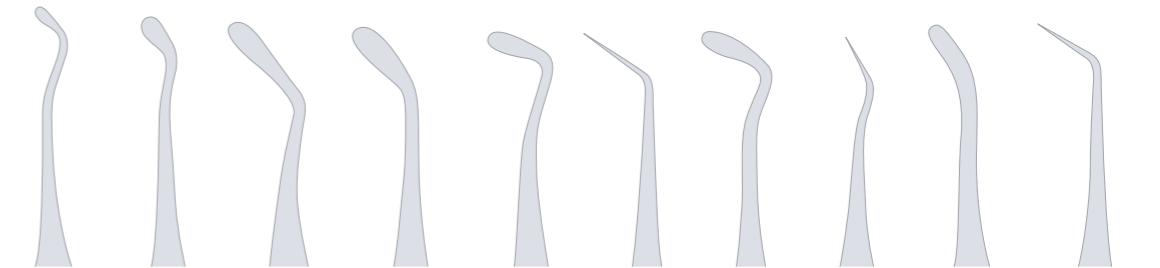

N° 0 N° 1 N° 2 N° 3 N° 4 N° 5 N° 6 N° 7 N° 8 N° 9



N° 1 N° 2 N° 3 N° 4 N° 5



1/4

84.251.00	N° 0	84.251.07	N° 7
84.251.01	N° 1	84.251.08	N° 8
84.251.02	N° 2	84.251.09	N° 9
84.251.03	N° 3		
84.251.04	N° 4		
84.251.05	N° 5		
84.251.06	N° 6		

LADMORE

84.261.01	N° 1
84.261.02	N° 2
84.261.03	N° 3
84.261.04	N° 4
84.261.05	N° 5

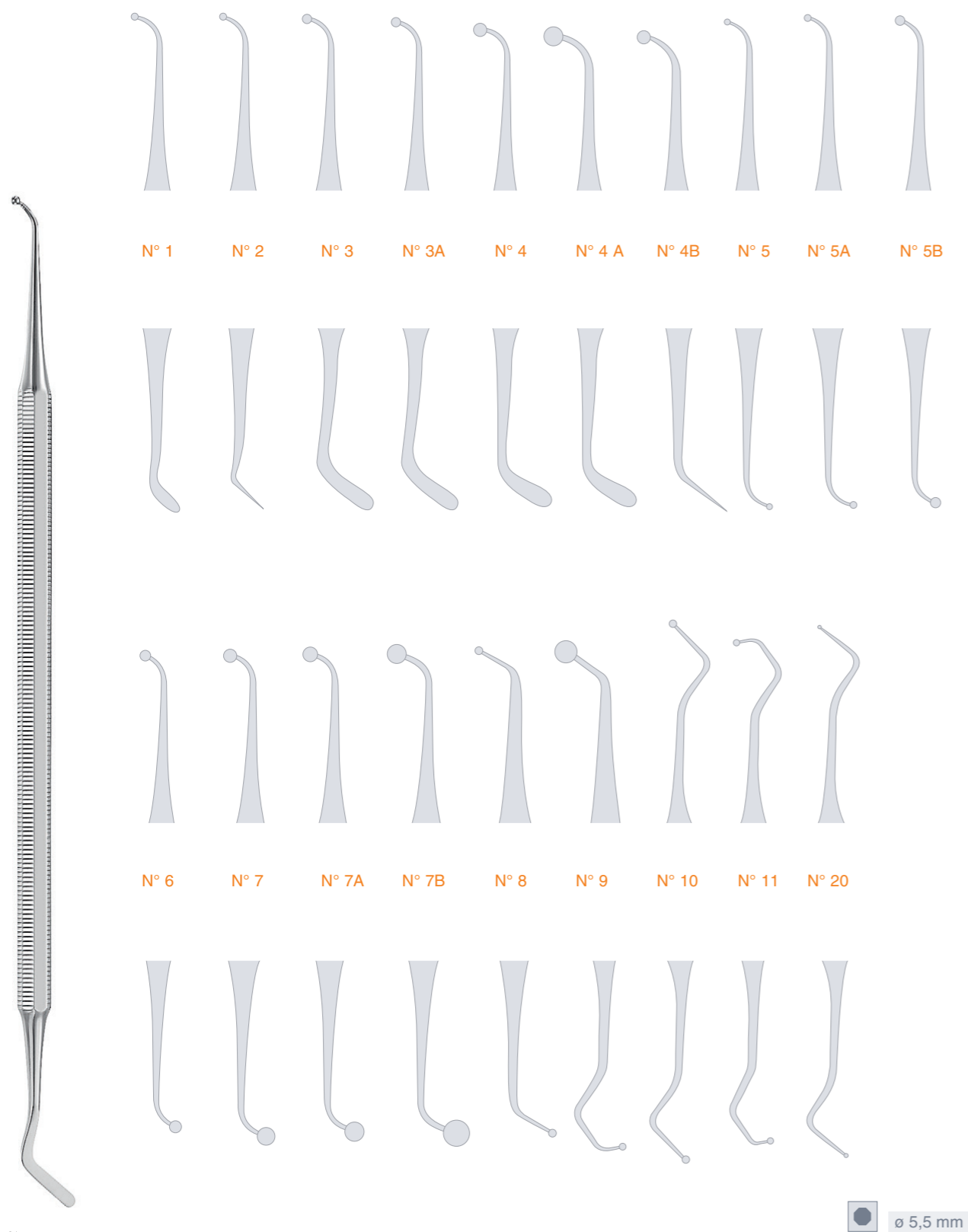

N° 1 N° 2 N° 3 N° 3A N° 4 N° 4 A N° 4B N° 5 N° 5A N° 5B

N° 6 N° 7 N° 7A N° 7B N° 8 N° 9 N° 10 N° 11 N° 20

ø 5,5 mm

84.270.10	N° 1	84.270.50	N° 5	84.270.80	N° 8
84.270.20	N° 2	84.270.51	N° 5A	84.270.90	N° 9
84.270.30	N° 3	84.270.52	N° 5B	84.271.10	N° 10
84.270.31	N° 3A	84.270.60	N° 6	84.271.11	N° 11
84.270.40	N° 4	84.270.70	N° 7	84.271.20	N° 20 DYCAL
84.270.41	N° 4A	84.270.71	N° 7A		
84.270.42	N° 4B	84.270.72	N° 7B		



HEIDEMANN N° 0 N° 1 N° 2 MOESLE N° 1 N° 2 SMITH N° 1 BALDWIN N° 49

WOODSON N° 1 N° 2 N° 3 WILLIAMS N° 0 N° 1 N° 2 LINSEMAN N° 3

ø 5,5 mm

HEIDEMANN		MOESLE		BALDWIN		WILLIAMS	
84.277.00	N° 0	84.278.01	N° 1	84.283.49	N° 49	84.321.00	N° 0
84.277.01	N° 1	84.278.02	N° 2			84.321.01	N° 1
84.277.02	N° 2			WOODSON		84.321.02	N° 2
		SMITH		84.311.01	N° 1	LINSEMAN	
		84.282.01	N° 1	84.311.02	N° 2	84.341.03	N° 3
				84.311.03	N° 3		

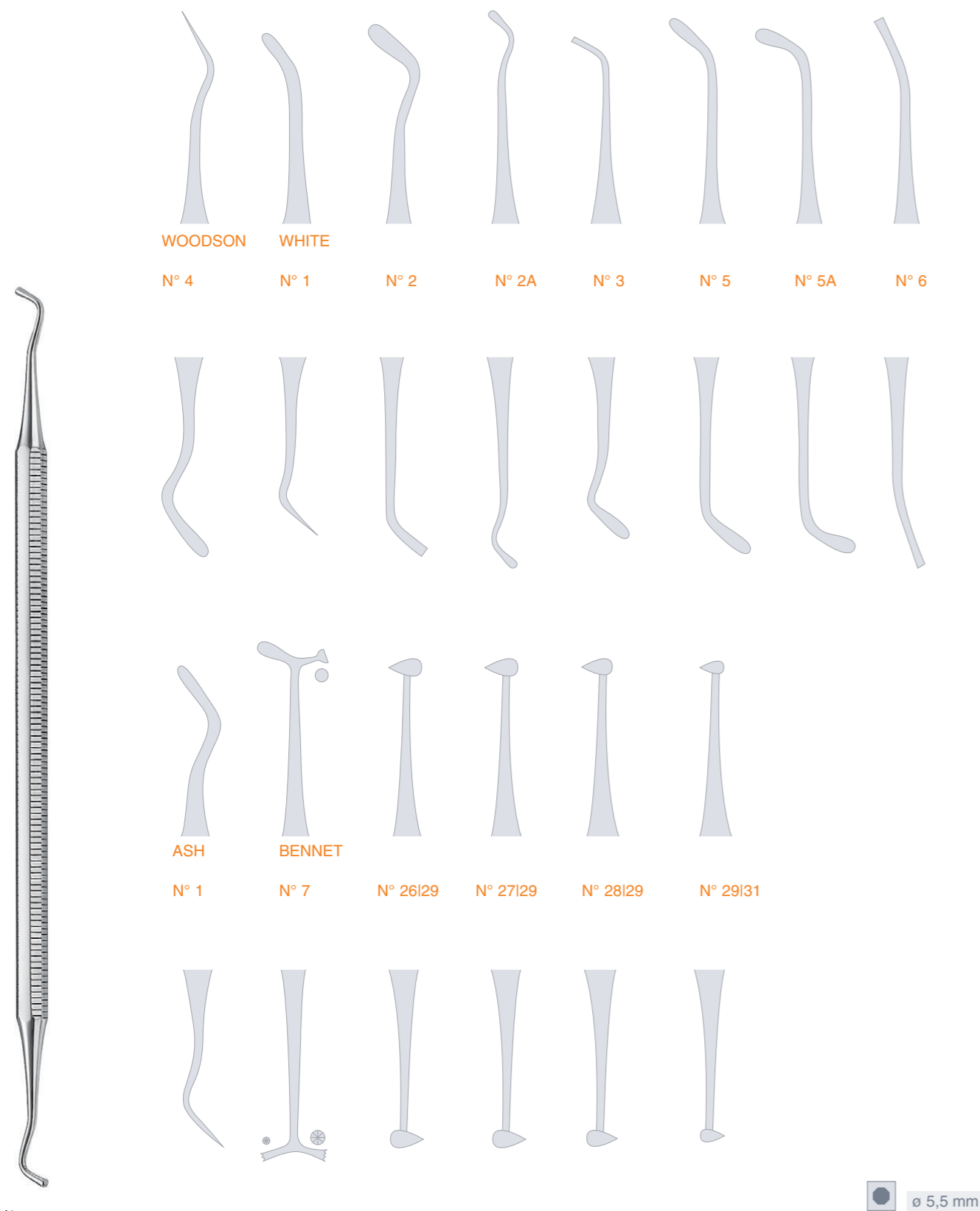

1/4 ● ø 5,5 mm

WOODSON	WHITE	ASH	BENNET
84.301.04 N° 4	84.305.10 N° 1	84.342.06 N° 1	84.349.07 N° 7
	84.305.20 N° 2		84.357.26 N° 26 29
	84.305.21 N° 2A		84.357.27 N° 27 29
	84.305.30 N° 3		84.357.28 N° 28 29
	84.305.50 N° 5		84.357.29 N° 29 31
	84.305.51 N° 5A		
	84.305.60 N° 6		



1/4 ● ø 5,5 mm

84.361.01 N° 1	84.361.09 N° 9
84.361.02 N° 2	84.361.10 N° 10
84.361.03 N° 3	84.361.11 N° 11
84.361.04 N° 4	84.361.12 N° 12
84.361.05 N° 5	84.361.13 N° 13
84.361.06 N° 6	84.361.14 N° 14
84.361.07 N° 7	84.361.15 N° 15
84.361.08 N° 8	84.361.16 N° 16



84.361.17	N° 17	84.361.25	N° 25	84.361.33	N° 33
84.361.18	N° 18	84.361.26	N° 26	84.361.34	N° 34
84.361.19	N° 19	84.361.27	N° 27	84.361.35	N° 35
84.361.20	N° 20	84.361.28	N° 28	84.361.36	N° 36
84.361.21	N° 21	84.361.29	N° 29	84.361.37	N° 37
84.361.22	N° 22	84.361.30	N° 30		
84.361.23	N° 23	84.361.31	N° 31		
84.361.24	N° 24	84.361.32	N° 32		



84.411.24	44 mm	N° 24	84.410.06	N° 6	84.408.02	N° 2	84.412.03	N° 3	84.412.04	N° 4
84.411.06	25 mm	N° A6	84.412.01	N° 1						
			84.412.02	N° 2						



84.404.10 9,5 x 7 cm

Anrührplatte aus Glas
mixing tablet, glass
plaque en verre à gâcher
placa de vidrio para mezclar
piastrella di vetro per mescolare

- | | | | | |
|-----------------|----------------|----------------|----------------|----------------|
| 84.420.36 N° 36 | 84.426.01 N° 1 | 84.431.01 N° 1 | 84.436.01 N° 1 | 84.436.04 N° 4 |
| | | 84.431.02 N° 2 | 84.436.02 N° 2 | 84.436.05 N° 5 |
| | | 84.431.03 N° 3 | 84.436.03 N° 3 | 84.436.06 N° 6 |



- | | | | |
|--------------------------------|---------------------------------|----------------------------------|---------------------------------|
| 1/2
IVORY
84.465.01 N° 1 | 1/2
IVORY
84.467.01 N° 12 | 1/2
IVORY
84.468.01 N° 12A | 1/2
IVORY
84.460.01 N° 14 |
|--------------------------------|---------------------------------|----------------------------------|---------------------------------|



- | | | |
|---------------------------|---------------------------|--|
| DIDNER
84.483.05 N° 8P | IVORY
84.481.05 N° 8 N | IVORY
84.480.05 5 mm N° 8
84.480.06 6 mm N° 8
84.480.07 7 mm N° 8 |
|---------------------------|---------------------------|--|



- | | |
|-------------------------|-----------------------|
| TOFFLEMIRE
84.477.01 | NYSTROEM
84.474.00 |
|-------------------------|-----------------------|



N° 1



N° 2



N° 3



N° 4



N° 5



N° 6

84.470.01	N° 1	84.470.04	N° 4	12 Stück
84.470.02	N° 2	84.470.05	N° 5	12 pièces
84.470.03	N° 3	84.470.06	N° 6	12 piezas
				12 pezzi



N° 1



N° 2



N° 3



N° 13

TOFFLEMIRE

84.482.01	N° 1	12 Stück
84.482.02	N° 2	12 pièces
84.482.03	N° 3	12 pièces
84.482.13	N° 13	12 piezas
		12 pezzi



84.485.05	5 mm
84.485.06	6 mm
84.485.07	7 mm



½

AINSWORTH

84.500.16 16 cml6¼"



½

IVORY

84.502.15 15 cml6"

Kofferdam-Lochzangen
rubberdam punch forceps
pinces perforatrices
perforadores para dique de goma
pinze per forare la diga di gomma



½

PALMER

84.505.17 17 cml6¾"



½

IVORY

84.506.16 16 cml6¼"



½

BREWER

84.513.17 17 cml6¾"

Kofferdam-Klammerzange
rubberdam clamp forceps
pinces à digue
pinzas de grapa para dique de goma
pinze per uncini



N° 26 N° 28 N° 30

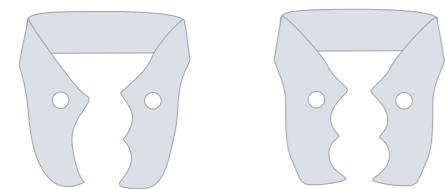

N° 31 N° 51



N° 27 N° 29 N° 60

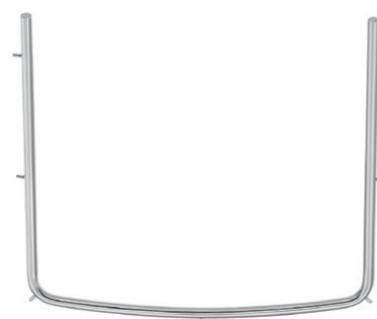

84.514.00 110 x 95 mm

Kofferdam-Rahmen
 rubberdam frame
 cadre à digue
 cuadro para dique de goma
 cornice per diga di gomma

IVORY

84.515.26	N° 26	84.515.30	N° 30
84.515.27	N° 27	84.515.31	N° 31
84.515.28	N° 28	84.515.51	N° 51
84.515.29	N° 29	84.515.60	N° 60

18

PROTHETIK
 PROSTHETICS
 PROTHÈSES
 PRÓTESIS
 PROTESI

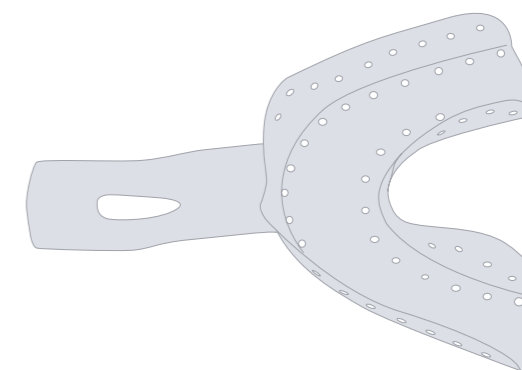

rostfrei 18|10
stainless steel 18|10
acier inoxydable 18|10
acero inoxidable 18|10
acciaio inossidabile 18|10



86.101.00	59 x 42 mm	BO 0
86.101.01	66 x 52 mm	BO 1
86.101.02	71 x 62 mm	BO 2
86.101.03	71 x 64 mm	BO 3
86.101.04	80 x 70 mm	BO 4

rostfrei 18|10
stainless steel 18|10
acier inoxydable 18|10
acero inoxidable 18|10
acciaio inossidabile 18|10



86.103.01	61 x 51 mm	FO 1
86.103.02	68 x 54 mm	FO 2
86.103.03	77 x 65 mm	FO 3

rostfrei 18|10
stainless steel 18|10
acier inoxydable 18|10
acero inoxidable 18|10
acciaio inossidabile 18|10



86.102.01	62 x 50 mm	PO 1
86.102.02	70 x 56 mm	PO 2
86.102.03	72 x 52 mm	PO 3

rostfrei 18|10
stainless steel 18|10
acier inoxydable 18|10
acero inoxidable 18|10
acciaio inossidabile 18|10



86.106.00	65 x 46 mm	BU 0
86.106.01	67 x 50 mm	BU 1
86.106.02	76 x 54 mm	BU 2
86.106.03	79 x 56 mm	BU 3
86.106.04	79 x 61 mm	BU 4

rostfrei 18|10
stainless steel 18|10
acier inoxydable 18|10
acero inoxidable 18|10
acciaio inossidabile 18|10



86.108.01	70 x 48 mm	UU 1
86.108.02	70 x 53 mm	UU 2
86.108.03	72 x 57 mm	UU 3
86.108.04	70 x 58 mm	UU 4

mit drehbarem Griff
with swivel handle
avec manche pivotant
con mango giratorio
con manico girevole



86.175.01



86.176.11

rostfrei 18|10
stainless steel 18|10
acier inoxydable 18|10
acero inoxidable 18|10
acciaio inossidabile 18|10



86.161.01	44 mm	N° 1
86.161.02	55 mm	N° 2
86.161.03	60 mm	N° 3
86.161.04	65 mm	N° 4

rostfrei 18|10
stainless steel 18|10
acier inoxydable 18|10
acero inoxidable 18|10
acciaio inossidabile 18|10



86.151.01	44 mm	N° 1
86.151.02	55 mm	N° 2
86.151.03	60 mm	N° 3
86.151.04	65 mm	N° 4



86.320.13

Weichgummi
 soft rubber
 caoutchouc mou
 goma blanda
 gomma morbida



1/4

SCHWARZ

86.280.17 16,5 cm | 6 1/2"



1/4

LICHTENSTEIN

86.288.17 17 cm | 6 3/4"



FAHNENSTOCK

86.482.13 13 cm | 5"
 86.482.17 17 cm | 6 3/4"



LESSMANN

86.484.13 13 cm | 5"
 86.484.17 17 cm | 6 3/4"



86.483.17 17 cm | 6 3/4"



GISY-WILD

86.480.15 15 cm | 6"



ANTKOVIAK

86.486.12 12,5 cm | 5"



86.488.00 14 cm | 5 1/2"



86.490.00 13,5 cm | 5 1/4"



GRITMAN

86.290.16 16 cm | 6 1/4"

Artikulationspapierpinzetten
articulating paper forceps
pinces pour papier d'articulation
pinzas para papel de articulación
pinze per carta di articolazione



1/1
BAUSCH
86.514.16 15,5 cm|6"



1/1
MILLER
86.517.15 15,5 cm|6"



1/1
BAUSCH
86.519.00 16 cm|6 1/4"

Kronensetzer aus Plexiglas
crown setter made of plexiglass
ajusteur de couronnes en plexiglas
fijador de coronas de plexiglas
fissatore de corona di plexiglas



SACHS
86.520.01

Bandtreiber
band pusher
ajusteur de bande
ajustador de bandas
regolatore di bande



MERSHON
86.528.01



SCHURE
86.530.00



87.757.18 18 cm|7"

Kronenabnehmer
crown remover
extracteur de couronnes
extractor de coronas
estrattore per corona



MILLER
86.580.01

Kronensetzer
crown setter
ajusteur de couronnes
fijador de coronas
fissatore de corona



TREYMAN
86.578.01



86.532.01 14,5 cm|5 3/4"



1/1
BOEHM
87.703.12 12 cm|4 3/4"
87.703.15 15 cm|6"



1/1
87.760.14 14,5 cm|5 3/4"



TRYFUS

87.740.16 16 cm 6 1/4"

Dentimeter
dentimeter
dentimètre
dentímetro
dentimetro



HOW

87.750.14 14 cm 5 1/2"

Kronenaufschneidezange
crown splitter
pince à fendre les couronnes
pinza para cortar coronas
pinza per tagliati corone



HOW

87.751.14 14 cm 5 1/2"



MOD.PARIS

86.546.01 16 cm 6 1/4"



MONFORT

86.590.19 19 cm 7 1/2"



87.754.00 14 cm 5 1/2"

87.754.12 Gummipolster (Paar)
rubber inserts (pair)
rembourrage en caoutchouc (paire)
bocas de goma (par)
cuscino di gomma (paio)

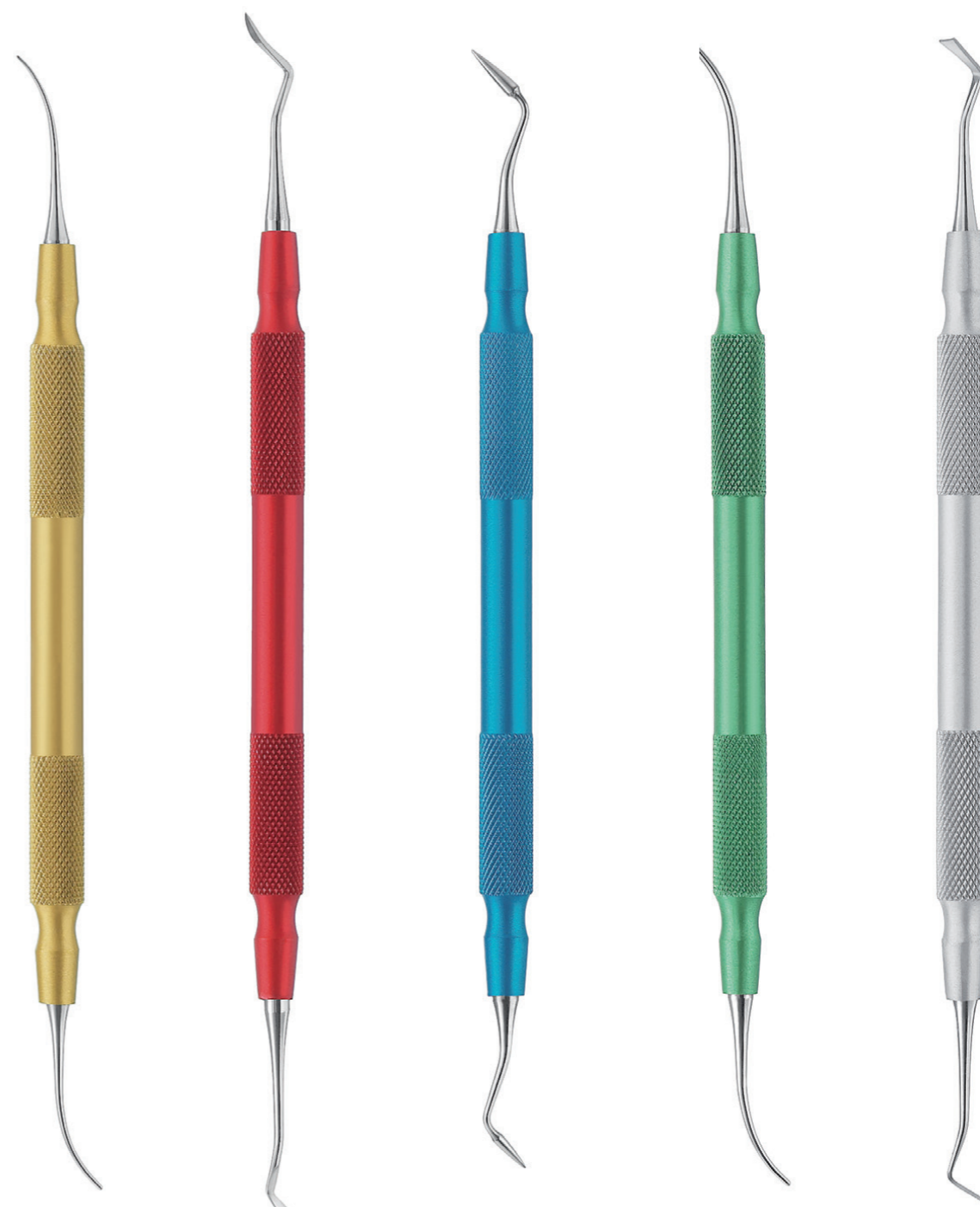

1/4

P. K. THOMAS

86.360.11 N° 1

1/4

P. K. THOMAS

86.360.12 N° 2

1/4

P. K. THOMAS

86.360.13 N° 3

1/4

P. K. THOMAS

86.360.14 N° 4

1/4

P. K. THOMAS

86.360.15 N° 5

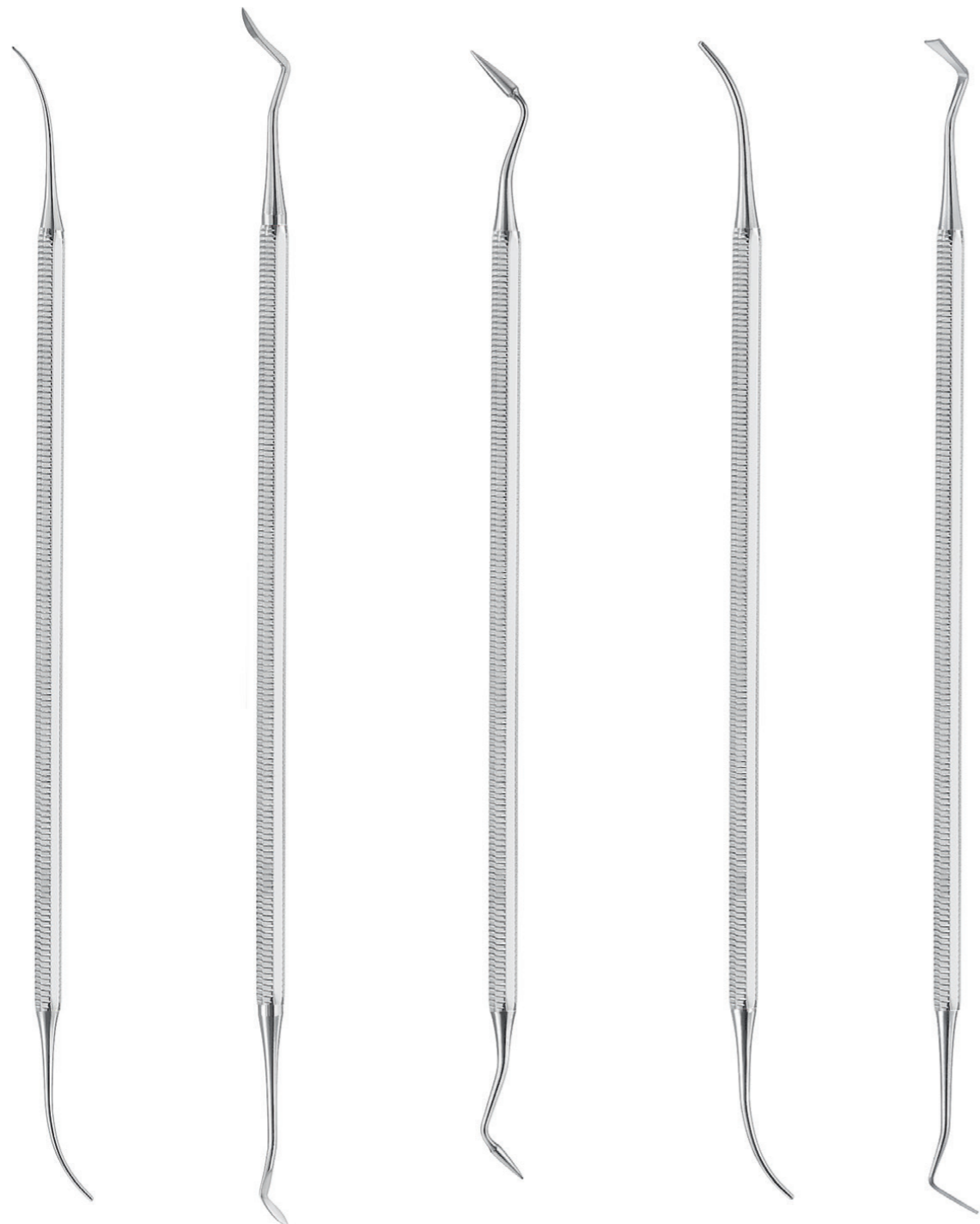

$\frac{1}{4}$	$\frac{1}{4}$	$\frac{1}{4}$	$\frac{1}{4}$	$\frac{1}{4}$
P. K. THOMAS	P. K. THOMAS	P. K. THOMAS	P. K. THOMAS	P. K. THOMAS
86.360.01 N° 1	86.360.02 N° 2	86.360.03 N° 3	86.360.04 N° 4	86.360.05 N° 5

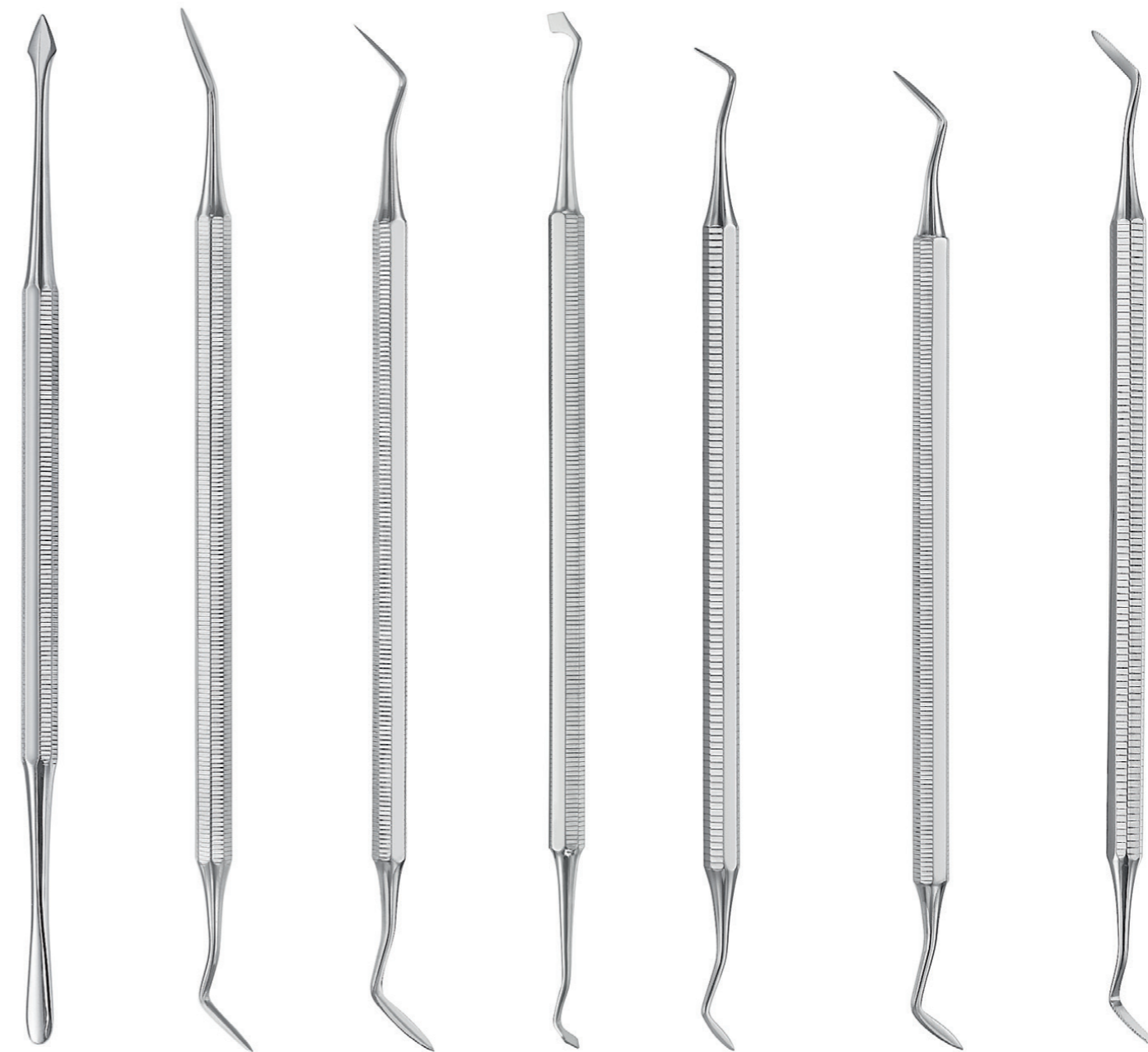

$\frac{1}{4}$	$\frac{1}{4}$	$\frac{1}{4}$	$\frac{1}{4}$	$\frac{1}{4}$	$\frac{1}{4}$	$\frac{1}{4}$
GRITMAN	WARD	WARD	FRAHM	HOLLENBACK	HOLLENBACK	WAERHAUG
86.350.01	86.354.01 N° 1	86.354.02 N° 2	86.356.01	86.370.31 N° 3S	86.370.30 N° 3	86.366.00

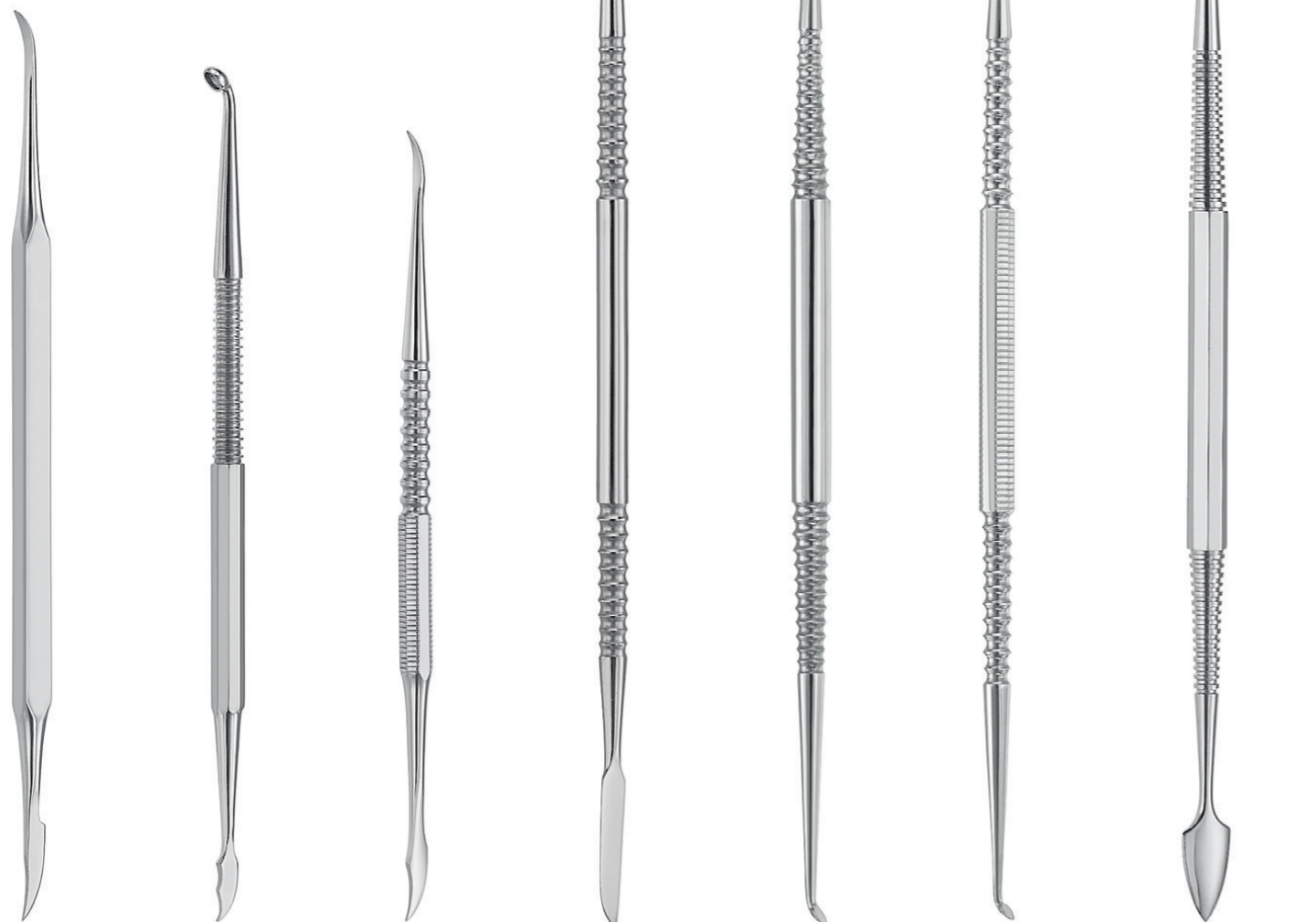

1/4	1/4	1/4	1/4	1/4	1/4	1/4
HYLIN	ZAHLE	ZAHLE	LE CRON	LE CRON	LE CRON	VEHE
86.392.01	86.394.01	86.395.01	86.401.01	86.402.01	86.403.01	86.410.01



1/4	1/4	1/4	1/4	1/4	1/4	1/4
FJELDSTAD	ROACH	ROACH	RIEGNER	FRAHM	FRAHM	FRAHM
86.416.01	86.424.01	86.425.01	86.428.01	86.435.01 N° 1	86.435.02 N° 2	86.435.06 N° 6



1/4	1/4	1/4	1/4	1/4	1/4
FRAHM	FRAHM	BEALE	BEALE	GRITMAN	WESTON
86.435.10 N° 10	86.436.00 N° 6/10	86.462.01 N° 7A	86.462.02	86.465.01	86.472.00

19

TECHNIKZANGEN
 MEDICAL PLIERS
 PINCES PROTHÉTIQUES
 PINZA PARA TÉCNICA
 TENAGLIE PER TECNICA

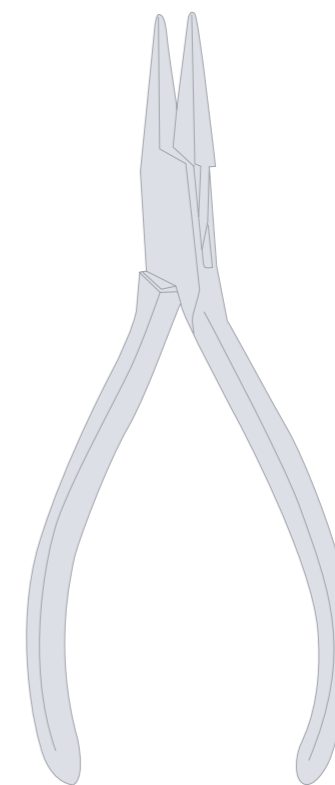



1/2
 87.505.14 14 cm 5 1/2"



1/2
LANGBECK
 87.517.14 15 cm 6"



1/2
 87.518.14 14 cm 5 1/2"



1/2
 87.521.13 12,5 cm 5"

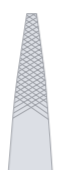

1/2
 87.522.13 13 cm 5"



1/2
 87.522.14 14 cm 5 1/2"



1/2
GOSLEE
 87.523.14 14 cm 5 1/2"

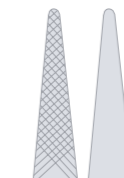

1/2
GOSLEE
 87.524.14 14 cm 5 1/2"



1/2
GOSLEE
 87.525.14 14 cm 5 1/2"

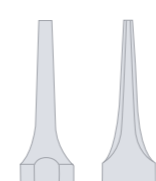

1/2
 87.538.15 15 cm 6"

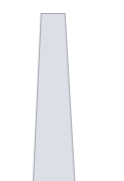

1/2
DUMONT
 87.554.11 11,5 cm 4 1/2"



1/2
DUMONT
 87.555.11 11,5 cm 4 1/2"





RUND- UND FLACHZANGEN
 FLAT AND ROUND NOSE PLIERS
 PINCES PLATES ET RONDES
 ALICATES DE PICO PLANO Y REDONDOS
 PINZE A PUNTE PIATTE E ROTONDE

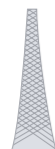

1/2
 87.542.13 13 cm|5"



1/2
 87.543.13 13 cm|5"



1/2
LANGBECK
 87.544.14 14 cm|5 1/2"



1/2
 87.526.12 12,5 cm|5"



1/2
 87.540.13 12,5 cm|5"



1/2
DUMONT
 87.556.11 11,5 cm|4 1/2"

DRAHTSCHNEIDEZANGEN
 WIRE CUTTERS
 PINCES COUPE-FILS
 ALICATES PARA DOBLAR ALAMBRE
 PINZE PIEGA FILO



1/2
 87.563.11 11 cm|4 1/4"



1/2
 87.563.12 11,5 cm|4 1/2" ■

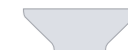

1/2
 87.564.12 12,5 cm|5"



1/2
 87.572.11 11,5 cm|4 1/2" ■



1/2
 87.572.12 11,5 cm|4 1/2" ■



1/2
 87.574.15 15 cm|6" ■



DRAHTBIEGEZANGEN
WIRE BENDING PLIERS
PINCES À PLIER
ALICATES PARA DOBLAR ALAMBRE
PINZE PIEGA FILO



½
SCHWARZ I
87.604.13 13 cm|5"



½
SCHWARZ II
87.606.13 13 cm|5"



½
SCHWARZ III
87.608.13 13 cm|5"



½
SCHWARZ
87.612.14 14,5 cm|5¾"



½
FISCHER
87.616.14 14 cm|5½"

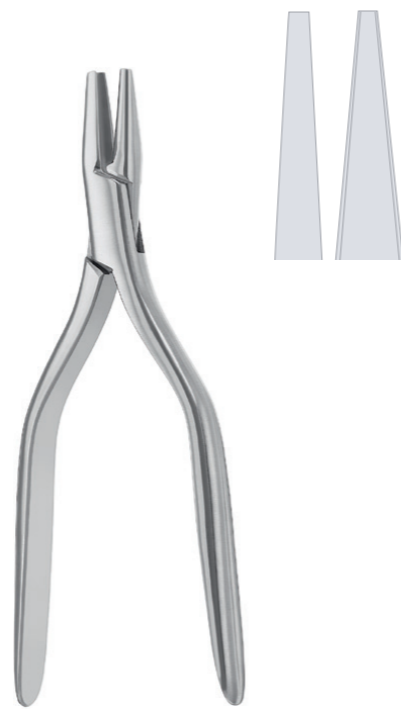

½
MCKELLOPS
87.624.17 17 cm|6¾"

DRAHTBIEGEZANGEN, SCHLAUFENBIEGEZANGEN
WIRE BENDING PLIERS, LOOP FORMING PLIERS
PINCES À PLIER, PINCES À FACONNER
ALICATES PARA DOBLAR ALAMBRE, ALICATES PARA PLIEGUES
PINZE PIEGA FILO, PINZE PER GRAFFE



½
MCKELLOPS-STADLER
87.626.16 16 cm|6¼"



½
STADLER
87.632.15 15 cm|6"



½
ANGLE
87.650.12 12,5 cm|5"



½
ANGLE
87.651.12 12,5 cm|5"



½
ANDRESEN
87.620.12 13,5 cm|5½"



½
ADAMS
87.654.13 13 cm|5"



DRAHTBIEGEZANGEN, SCHLAUFENBIEGEZANGEN
 WIRE BENDING PLIERS, LOOP FORMING PLIERS
 PINCES À PLIER, PINCES À FACONNER
 ALICATES PARA DOBLAR ALAMBRE, ALICATES PARA PLIEGUES
 PINZE PIEGA FILO, PINZE PER GRAFFE

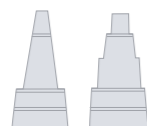

1/2
YOUNG
 87.660.13 13 cm|5"

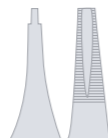

1/2
TWEED
 87.661.14 13,5 cm|5 1/2"

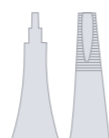

1/2
TWEED
 87.662.14 13,5 cm|5 1/2"



1/2
DE LA ROSA
 87.663.00 12,5 cm|5"



1/2
DE LA ROSA
 87.663.02 12,5 cm|5"

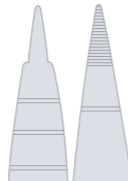

1/2
JARABAK
 87.664.14 14 cm|5 1/2"



DRAHTBIEGEZANGEN, KLAMMERBIEGEZANGEN
 WIRE BENDING PLIERS, LOOP FORMING PLIERS
 PINCES À PLIER, PINCES À FACONNER
 ALICATES PARA DOBLAR ALAMBRE, ALICATES PARA PLIEGUES
 PINZE PIEGA FILO, PINZE PER GRAFFE



1/2
ADERER
 87.666.14 14 cm|5 1/2"

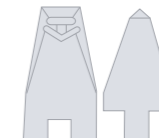

1/2
KOEHLER
 87.667.12 12 cm|4 3/4"



1/2
87.668.14 14 cm|5 1/2"



1/2
ADERER
 87.672.12 11,5 cm|4 1/2"



1/2
ADERER
 87.674.13 12,5 cm|5"



KRAMPONZANGEN
 UNIVERSAL BENDING PLIERS
 PINCES UNIVERSELLES À CRAMPON
 ALICATES UNIVERSALES
 PINZE PIEGHE UNIVERSALE



1/2
ANGLE
 87.678.13 13 cm 5"



1/2
ANGLE
 87.679.13 13 cm 5"



1/2
WALDSACHS-UNIVERSAL
 87.690.15 15,5 cm 6"

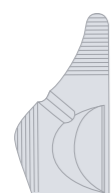

1/2
UNIVERSAL
 87.694.15 15,5 cm 6"



1/2
UNIVERSAL
 87.697.15 15,5 cm 6"



1/2
OLIVER-JONES
 87.705.15 15 cm 6"



1/2
OLIVER
 87.707.15 15 cm 6"



1/2
OLIVER
 87.709.15 15 cm 6"



1/2
ADERER
 87.710.13 13,5 cm 5 1/4"

Polster aus Teflon
 teflon inserts
 rembourrage en téflon
 bocas de teflón
 cuscino di teflon

BANDABNEHMEZANGEN
 BAND REMOVING PLIERS
 PINCES ENLÈVE BAGUES
 ALICATES PARA QUITAR BANDAS
 PINZE ASPORTABANDE





½
WEINGART
87.711.14 14 cm 5½"



½
WEINGART
87.713.14 14 cm 5½"



½
KORKHAUS
87.714.05 16,5 cm 6½"



½
ANGLE
87.796.13 13 cm 5"



½
ANGLE
87.797.13 13 cm 5"



½
PEESO
87.742.12 12 cm 4¾"



½
PEESO
87.744.14 13,5 cm 5¼"



½
PEESO
87.770.14 14 cm 5½"



½
FREVERT
87.776.12 12 cm 4¾"



½
TRIPLEX
87.780.14 14 cm 5½"



½
REYNOLD
87.783.12 13 cm 5"





KONTURZANGEN
 CONTOURING PLIERS
 PINCES À CONTOURE
 ALICATES PARA CONTORNEAR
 TENAGLIE PER PROFILI



½
GORDON
 87.785.14 14 cm 5½"

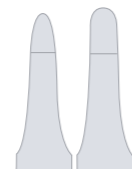

½
JOHNSON
 87.788.13 13,5 cm 5¼"

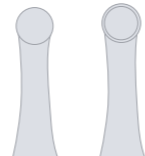

½
ABELL
 87.794.13 13 cm 5"



Beispiel
 example
 exemple
 ejemplo
 esempio

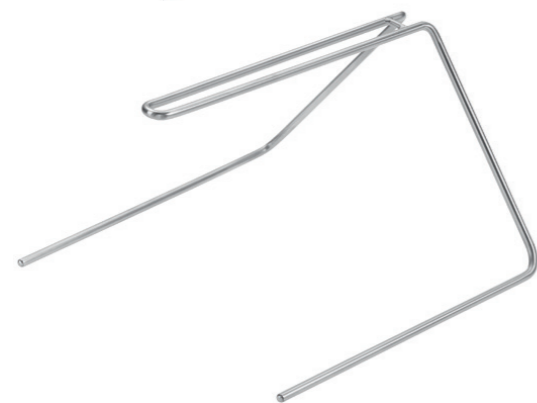

½
ABELL
 87.798.00 22 cm 8¾"
 Ständer
 support
 support
 soporte
 supporto



NANCE
 87.771.13 12,5 cm 5"
 Stufenbiegezange
 step loop bending plier
 pince à courber à gradins
 alicate para doblar escalonada
 pinza piegata a gradini



FURRER
 87.702.15 15 cm 6"
 Kupferring Abnehmzange
 copper ring removing pliers
 pince enlève bagues en cuivres
 alicate para quitar anillos en cobre
 pinza aspartabande di rame

20

■ HYGIENE
 HYGIENE
 HYGIÈNE
 HIGIENE
 IGIENE

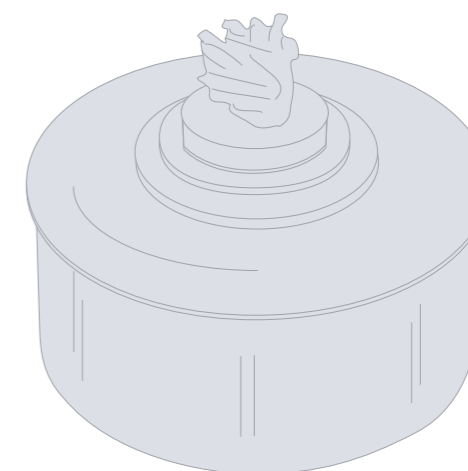



½

DAVIS

28.102.16	16 cm 6¼"
28.102.20	20 cm 8"
28.102.24	24 cm 9½"



½

UNIVERSAL

28.121.20	20 cm 8"	☐
28.121.28	28 cm 11"	☐



½

UNIVERSAL

28.120.20	20 cm 8"	☐
28.120.28	28 cm 11"	☐



CHEATLE

28.110.27	27 cm 10¾"
-----------	------------



ROGGE

28.130.23	23 cm 9"
-----------	----------



28.140.20	20 cm 8"
28.140.30	30 cm 12"



87.912.12 120 ml



87.904.07 75 ml



87.901.12 100 ml



87.920.12 120 ml



87.924.05 50 ml



87.947.04 12 cm 4¾"



Mikrocontainer aus Edelstahl
micro containers made of stainless steel
micro conteneurs en acier inoxydable
micro contenedores de acero inoxidable
micro container de acciaio inossidabile



	L x B x H	L x B x H
88.290.01	200 x 140 x 45 mm	220 x 165 x 55 mm
88.290.04	280 x 195 x 45 mm	300 x 220 x 55 mm
88.290.05	265 x 255 x 45 mm	285 x 280 x 55 mm

Sterilisierkassetten mit Silikon-Noppenstreifen
sterilization cases with silicone cushioning stripes
cassettes de stérilisation avec picots en silicone
casetes de esterilización con bandas de silicona acolchada
sterilizzazione dei cassette con imbottitura strisce di silicone



Dentalcontainer aus Aluminium
dental containers made of aluminium
conteneurs dentaires en aluminium
contenedores dentales de aluminio
container dentali de alluminio



	L x B x H
88.650.01	310 x 190 x 40 mm
88.650.02	310 x 190 x 65 mm
88.650.03	310 x 190 x 130 mm



	L x B x H	
88.698.39	265 x 175 x 43 mm	Siebkorb aus Edelstahl
88.698.00		1 stainless steel basket
88.698.38		2 paniers grillagés d'acier inoxydable
		cesta perforada de acero inoxidable
		cestino perforato di acciaio inossidabile



88.695.01	60 x 40 mm	Einschlagtuch aus Baumwolle
88.695.02	65 x 65 mm	cotton wrapping cloth
88.695.03	85 x 85 mm	tissu en coton
		pañños de algodón
		telo de cotone



	L x B x H	
88.118.50	50 x 25 x 4,5 mm	Nadeldose
88.118.65	65 x 42 x 8 mm	needle case
88.118.75	75 x 25 x 4,5 mm	boîte à aiguille
		estuche para agujas
		scatola per aghi



LAGERUNGSTRAY
STORAGE TRAY
BACINELLE (ODER PLATEAUX) À STOCKAGE
TRAY PARA DEPOSITAR
BACINELLE PER IL DEPOSITO

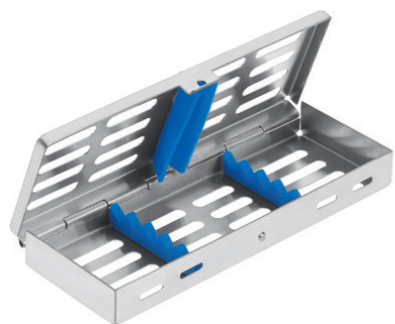

88.121.65B für 5 Instrumente
 for 5 instruments
 pour 5 instruments
 para 5 instrumentos
 per 5 strumenti

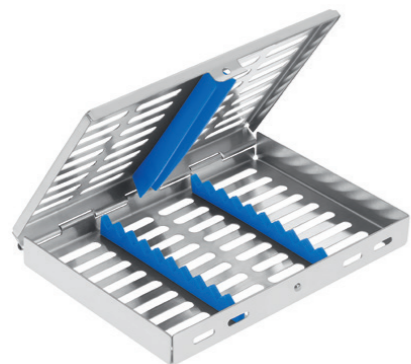

88.121.70B für 10 Instrumente
 for 10 instruments
 pour 10 instruments
 para 10 instrumentos
 per 10 strumenti

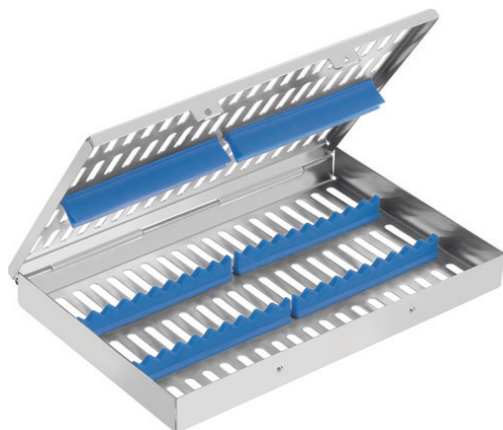

88.121.69B für 20 Instrumente
 for 20 instruments
 pour 20 instruments
 para 20 instrumentos
 per 20 strumenti

aus Edelstahl
 made of stainless steel
 en acier inoxydable
 de acero inoxidable
 de acciaio inossidabile

21

■ **VERSCHIEDENES**
 MISCELLANEOUS
 DIVERS
 DIVERSOS
 DIVERSI

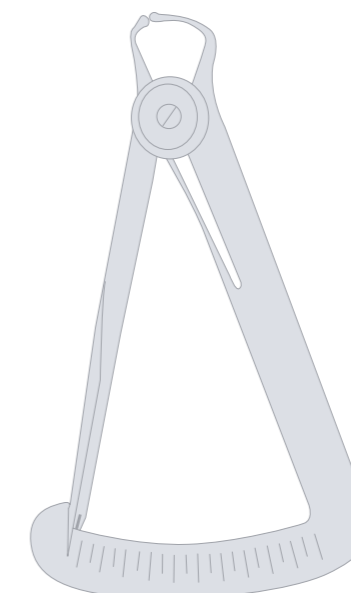



87.220.05 Klammer für Röntgenbild
clip for x-ray
clip pour radiographie
pinza para radiografía
pinza per radiografia



74.398.00 Handwaschbürste
hand brush
brosse à mains
cepillo para uñas
spazzola per unghie



87.853.00 Messinstrument für Bracketpositionierung
bracket positioning gauge
instrument de mesure pour le positionnement des brackets
instrumento para medir la posición de los braquets
strumento di misura per el posizionamento del bracket



87.852.00 14 cm15½"



87.852.01 14 cm15½"



87.852.02 12 cm14¾"

Brackethalter
bracket holder
porte-bracket
porta bracket
porta bracket



für Metall
for metal
pour métal
para metal
per metallo



IWANSON
87.834.15 12 cm4¾"
0-10 mm

für Wachs
for wax
pour cire
para cera
per cera



IWANSON
87.836.15 12 cm4¾"
0-10 mm



BOLEY
87.816.10 16 cm6¼"
0-100 mm



½
CASTROVIEJO-EPKER
48.992.09 9 cm13½" 40 mm



½
CASTROVIEJO-EPKER
48.992.18 18 cm7" 40 mm



1/2

02.340.10	10 cm 4"
02.340.20	20 cm 8"
02.340.30	30 cm 12"
02.340.40	40 cm 16"



1/2

02.344.15	15 cm 6"
-----------	----------

22

HOCHFREQUENZ-CHIRURGIE
HIGH FREQUENCY SURGERY
CHIRURGIE HAUTE FRÉQUENCE
ELECTROCIRUGÍA
ELETTROCHIRURGIA



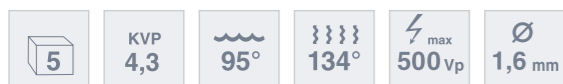

90.010.01 ø 0,2 mm N° 1 Nadelelektrode
 needle electrode
 électrode à aiguille
 electrodo de aguja
 elettrodo di ago



90.010.02 ø 0,2 mm|45° N° 2 Nadelelektrode
 needle electrode
 électrode à aiguille
 electrodo de aguja
 elettrodo di ago



90.010.11 ø 3 mm N° 11 Drahtschlingenelektrode
 wire loop electrode
 électrode anse à fil
 electrodo de asa de alambre
 elettrodo di ansa di filo



90.010.12 ø 5 mm N° 12 Drahtschlingenelektrode
 wire loop electrode
 électrode anse à fil
 electrodo de asa de alambre
 elettrodo di ansa di filo



90.010.13 ø 8 mm N° 13 Drahtschlingenelektrode
 wire loop electrode
 électrode anse à fil
 electrodo de asa de alambre
 elettrodo di ansa di filo



90.010.33 ø 1,7 mm|45° N° 33 Kugelelektrode
 ball electrode
 électrode à boule
 electrodo de bola
 elettrodo di sfera



90.010.34 ø 3 mm|45° N° 34 Kugelelektrode
 ball electrode
 électrode à boule
 electrodo de bola
 elettrodo di sfera



90.010.35 ø 0,6 mm N° 35 Koagulations-und Fulgurationselektrode
 coagulation and fulguration electrode
 électrode de coagulation et fulguration
 electrodo para coagulación y fulguración
 elettrodo per coagulazione e folgorazione

Elektrodenanschluss
 electrode connection
 connexion d'électrode
 conexión de electrodo
 raccordo di elettrodo



90.066.02
 Erbe ICC / ACC, Storz



90.066.04



90.066.06
 Martin / Berchtold / Integra

Kabellänge 3 m
 cable length 3 m
 encablure 3 m
 longitud del cable 3 m
 lunghezza cavo 3 m

Handgriff für 1,6 mm Schaft-Elektrode
 handle for 1,6 mm shaft-electrode
 manche pour électrode avec tige de 1,6 mm
 mango para electrodos con asta de 1,6 mm
 manico per elettrodi con asta de 1,6 mm



► Wenn Sie Interesse an weiteren Elektroden haben, kontaktieren Sie uns gerne.
 In case you are interested in other electrodes, please do not hesitate to contact us.
 Si vous vous intéressez à d'autres électrodes, n'hésitez pas à nous contacter.
 En caso de que se interesen por otros electrodos, no tardarían en contactarnos.
 Se avete interesse a altri elettrodi, non esitate a contattarci.



Wenn Sie Interesse an Mikromotorsysteme im Dentalbereich haben, kontaktieren Sie uns gerne.
In case you are interested in micro motors for dental surgery, please do not hesitate to contact us.
Si vous vous intéressez aux micromoteurs dans le secteur dentaire, n'hésitez pas à nous contacter.
En caso de que se interesen por micro motores para cirugía dental, no hesitan en contactarnos.
Se avete interesse a motori micro per chirurgia dentale, non esitate a contattarci.

23

NUMMERISCHES VERZEICHNIS
NUMERICAL INDEX
INDEX NUMÉRIQUE
ÍNDICE NUMÉRICO
INDICE NUMERICO

02		06.212.00	9	08.285.11	16	08.825.12	22	10.130.14	29	14.123.11	43
		06.212.02	9	08.285.15	16	08.831.12	24	10.170.12	28	14.123.13	43
02.340.10	246	06.215.00	9	08.285.18	16	08.835.12	24	10.173.12	28	14.123.14	43
02.340.20	246	06.215.01	9	08.286.15	17	08.850.10	24	10.174.12	28		
02.340.30	246	06.218.00	9	08.287.15	17	08.851.10	24	10.176.12	28	16	
02.340.40	246	06.219.00	9	08.288.14	16	08.853.10	24	10.180.12	28		
02.344.15	246	06.220.00	9	08.289.14	16	08.854.12	24	10.186.12	28	16.110.20	44
		06.221.00	9	08.292.14	17	08.855.12	24	10.220.17	30	16.111.20	44
		06.222.00	9	08.293.14	17	08.901.11	26	10.224.17	30		
		06.223.00	9	08.296.14	17	08.901.14	26	10.230.17	30	18	
04.165.00	2	06.224.00	9	08.297.14	17	08.901.16	26	10.260.12	30		
04.165.01	2	06.302.09	10	08.302.14	15	08.901.18	26	10.260.15	30	18.102.12	46
04.165.02	2	06.302.13	10	08.303.14	15	08.901.20	26	10.270.12	30	18.120.00	46
04.165.03	2	06.304.15	10	08.304.14	15	08.950.15	26	10.270.15	30	18.120.14	46
04.165.04	2	06.408.01	10	08.305.14	15	08.950.15B	26	10.272.15	30	18.120.15	46
04.165.11	2	06.408.02	10	08.306.11	18	08.950.15G	26	10.274.17	31	18.120.17	46
04.165.12	2			08.307.11	18	08.950.15Y	26	10.276.17	31	18.120.18	46
04.165.13	2	08		08.308.14	15	08.950.15R	26	10.288.20	31	18.160.17	46
04.165.14	2			08.309.14	15	08.950.15W	26	10.290.20	31	18.161.17	46
04.170.01	2	08.102.13	12	08.310.12	19	08.950.18	26	10.302.18	31	18.220.02	46
04.170.02	2	08.102.14	12	08.310.15	19	08.950.18B	26	10.310.18	31	18.220.03	46
04.170.03	2	08.103.13	12	08.314.12	19	08.950.18G	26	10.330.12	32	18.220.04	46
04.171.02	3	08.103.14	12	08.314.15	19	08.950.18Y	26	10.346.15	32	18.226.02	47
04.171.03	3	08.104.14	12	08.315.16	21	08.950.18R	26	10.348.15	32	18.226.03	47
04.171.04	3	08.105.14	12	08.317.16	21	08.950.18W	26	10.349.15	32	18.226.04	47
04.171.05	3	08.110.13	12	08.317.17	21			10.821.11	32	18.228.08	47
04.171.06	3	08.110.14	12	08.321.15	19	09		10.822.13	32	18.228.09	47
04.171.15	3	08.111.13	12	08.321.18	19			10.823.13	32	18.250.03	48
04.171.25	3	08.111.14	12	08.340.09	20	09.710.15	25	10.823.90	32	18.252.03	48
04.172.02	3	08.114.14	12	08.340.10	20	09.710.18	25	10.828.15	32	18.252.04	48
04.172.03	3	08.115.14	12	08.340.11	20	09.710.21	25			18.254.03	48
04.172.04	3	08.120.13	13	08.340.12	20	09.710.23	25	11		18.254.04	48
04.172.05	3	08.120.14	13	08.341.09	20	09.711.15	25			18.281.02	47
04.172.06	3	08.121.13	13	08.341.10	20	09.711.18	25	11.304.16	33	18.310.01	48
04.172.15	3	08.121.14	13	08.341.11	20	09.711.21	25	11.304.20	33	18.310.02	48
04.172.25	3	08.122.01	13	08.341.12	20	09.711.23	25	11.306.16	33	18.310.03	48
		08.122.02	13	08.344.11	20	09.712.15	25	11.306.20	33	18.310.04	48
		08.122.03	13	08.345.11	20	09.712.18	25	11.308.16	33	18.342.05	49
		08.123.01	13	08.351.11	20	09.712.21	25	11.308.20	33	18.342.06	49
06.103.00	6	08.123.02	13	08.353.11	20	09.712.23	25	11.309.16	33	18.344.14	49
06.103.01	6	08.123.03	13	08.425.17	21	09.713.15	25	11.309.20	33	18.344.20	49
06.103.03	6	08.124.12	14	08.427.17	21	09.713.18	25			18.348.22	49
06.103.11	6	08.124.14	13	08.540.16	14	09.713.21	25	12		18.354.21	49
06.103.15	7	08.125.12	14	08.541.16	14	09.713.23	25			18.620.07	52
06.103.33	7	08.125.14	13	08.542.16	14	09.720.15	25	12.220.12	40	18.620.10	52
06.104.03	8	08.126.12	14	08.543.16	14	09.720.18	25	12.221.12	40	18.670.14	52
06.105.00	7	08.126.13	14	08.582.15	18	09.720.21	25	12.230.12	40	18.671.14	52
06.107.00	7	08.127.12	14	08.583.15	18	09.721.15	25	12.231.12	40		
06.107.01	7	08.127.13	14	08.584.13	18	09.721.18	25	12.240.14	40	20	
06.110.00	6	08.140.14	14	08.584.15	18	09.721.21	25	12.241.14	40		
06.111.00	6	08.141.14	14	08.609.17	19	09.722.15	25	12.242.16	41	20.104.11	82
06.112.00	6	08.196.16	16	08.609.18	19	09.722.18	25	12.243.16	41	20.104.13	82
06.112.02	6	08.197.16	16	08.613.17	19	09.722.21	25	12.250.14	41	20.104.14	82
06.115.00	6	08.210.11	16	08.802.09	23	09.723.15	25	12.251.14	41		
06.115.01	6	08.211.11	16	08.802.11	23	09.723.18	25	12.270.14	42	24	
06.118.00	8	08.215.17	16	08.802.12	23	09.723.21	25	12.271.14	42		
06.119.00	8	08.278.14	16	08.803.09	23			12.310.14	42	24.130.13	54
06.120.00	8	08.279.14	16	08.803.13	23	10		12.311.14	42	24.134.13	54
06.121.02	8	08.280.15	16	08.804.14	23			12.320.14	43	24.140.13	54
06.122.00	8	08.280.18	16	08.806.14	23	10.102.13	29	12.321.14	43	24.144.13	54
06.123.00	8	08.281.15	16	08.806.18	23	10.102.14	29	12.368.14	42	24.150.12	54
06.124.00	8	08.281.18	16	08.810.12	23	10.110.13	29			24.150.14	54
06.125.00	8	08.282.15	17	08.820.13	22	10.110.14	29	14		24.154.12	54
06.136.00	8	08.283.15	17	08.821.13	22	10.114.14	29			24.154.14	54
06.199.00	10	08.284.11	16	08.822.13	22	10.120.13	29	14.101.09	43	24.160.15	54
06.210.00	9	08.284.15	16	08.823.13	22	10.120.14	29	14.111.09	43	24.164.15	54
06.211.00	9	08.284.18	16	08.824.12	22	10.130.13	29	14.111.11	43	24.170.15	55

24.174.15	55	32.117.15	63	40.290.21	4	48.235.19	51	80.004.00	92	80.851.09	137
24.180.16	55	32.119.15	63	40.294.05	4	48.250.16	89	80.007.00	93		
24.180.18	55	32.131.15	63	40.295.06	3	48.250.18	89	80.013.00	93	81	
24.184.16	55	32.133.15	63	40.295.07	3	48.255.16	89	80.017.00	93		
24.184.18	55	32.201.18	64	40.295.08	3	48.255.99	89	80.018.00	94	81.001.00	108
24.194.18	55	32.211.15	64	40.295.09	3	48.265.12	87	80.018.01	94	81.001.01	108
24.214.18	55	32.213.15	64	40.295.10	3	48.265.14	87	80.022.00	94	81.001.02	108
24.224.15	56	32.216.18	64	40.295.11	3	48.267.12	87	80.023.00	95	81.003.00	109
24.224.18	56	32.217.18	64	40.295.12	3	48.270.16	87	80.024.00	95	81.003.04	109
24.226.15	56	32.386.20	65	40.295.15	3	48.270.19	87	80.029.00	95	81.003.09	109
24.280.14	56	32.407.19	65	40.297.06	3	48.272.13	87	80.033.00	96	81.005.00	110
24.280.18	56	32.409.13	65	40.297.07	3	48.274.09	87	80.033.01	96	81.006.00	110
24.360.18	56	32.470.00	68	40.297.08	3	48.274.11	87	80.033.03	96	81.010.04	110
24.364.18	56	32.470.01	68	40.297.09	3	48.274.13	87	80.033.06	97	81.010.09	111
24.370.14	57	32.470.02	68	40.297.10	3	48.274.15	87	80.034.00	97	81.015.00	111
24.370.17	57	32.470.03	68	40.297.11	3	48.314.00	89	80.035.00	97	81.016.00	111
24.374.14	57	32.470.05	68	40.297.12	3	48.330.00	88	80.036.02	98	81.016.09	112
24.374.17	57	32.496.00	68	40.297.15	3	48.330.01	88	80.041.00	98	81.017.00	112
24.386.20	56	32.496.01	68	40.313.15	4	48.330.02	88	80.045.00	98	81.018.05	112
24.390.14	57	32.496.12	68	40.313.20	4	48.330.03	88	80.046.1			

82

82.001.05	140	82.533.20	149	82.608.22	157	82.871.33R	71	83.109.01	36	83.326.07	175
82.001.08	140	82.533.21	149	82.609.18	157	82.889.11	72	83.109.02	36	83.326.08	175
82.002.00	140	82.533.22	149	82.609.22	157	82.889.22	72	83.109.03	36	83.326.09	175
82.003.00	140	82.533.23	149	82.610.42	159	82.890.05	72	83.109.04	36	83.326.10	175
82.003.01	140	82.533.70	149	82.611.18	157	82.895.01	73	83.115.03	37	83.326.11	175
82.004.05	140	82.540.20	145	82.652.00	160	82.895.02	73	83.115.04	37	83.326.21	175
82.004.08	140	82.540.25	145	82.652.01	160	82.895.03	73	83.120.12	37	83.327.02	176
82.006.00	140	82.540.30	145	82.661.00	160	82.895.04	74	83.121.12	37	83.327.02H1	177
82.008.00	140	82.551.05	150	82.702.16	162	82.895.05	74	83.230.01	168	83.327.04	176
82.009.00	140	82.551.08	150	82.702.20	162	82.896.01	74	83.231.01	168	83.327.04H1	177
82.010.00	140	82.553.08	150	82.702.22	162	82.898.17	75	83.237.00	168	83.327.06	176
82.011.00	140	82.554.05	150	82.702.24	162	82.899.16	75	83.239.01	168	83.327.06H1	177
82.012.00	140	82.554.08	150	82.703.22	162	82.902.18	76	83.239.02	168	83.327.08	176
82.027.00	141	82.561.01	148	82.703.24	162	82.905.22	76	83.243.01	168	83.327.08H1	177
82.027.01	141	82.567.01	148	82.704.22	162	82.905.23	76	83.243.02	168	83.327.10	176
82.028.00	141	82.567.02	148	82.704.24	162	82.906.12	74	83.245.01	168	83.327.10H1	177
82.028.01	141	82.571.01	147	82.705.20	162	82.909.01	72	83.245.02	168	83.327.12	176
82.034.00	141	82.571.02	147	82.705.22	162	82.909.24	78	83.245.03	168	83.327.12H1	177
82.034.09	141	82.577.01	153	82.705.24	162	82.910.09	78	83.245.33	168	83.327.13	176
82.039.00	141	82.577.02	153	82.706.20	162	82.921.14	77	83.245.38	168	83.327.13H1	177
82.040.00	141	82.577.03	153	82.706.22	162			83.250.00	169	83.327.14	176
82.046.00	141	82.577.04	153	82.706.24	162			83.250.01	169	83.327.14H1	177
82.050.00	141	82.580.00	154	82.721.04	163	83.029.01	34	83.250.02	169	83.327.16	176
82.051.00	141	82.580.01	154	82.721.14	163	83.029.03	34	83.250.03	169	83.327.16H1	177
82.301.00	142	82.580.02	154	82.726.01	163	83.029.05	34	83.250.04	169	83.328.06	172
82.302.00	142	82.580.03	154	82.728.00	164	83.029.06	34	83.250.05	169	83.328.61	172
82.303.00	142	82.580.04	154	82.728.01	164	83.031.01	34	83.250.06	169	83.329.24	172
82.304.00	142	82.580.05	154	82.728.02	164	83.031.02	34	83.250.07	169	83.330.00	172
82.405.01	142	82.580.06	154	82.730.01	164	83.031.03	34	83.250.08	169	83.331.15	178
82.405.02	142	82.580.07	154	82.731.00	164	83.031.04	34	83.251.11	170	83.331.16	178
82.405.03	142	82.580.08	154	82.738.01	165	83.031.05	34	83.271.02	170	83.332.16	178
82.410.01	143	82.580.09	154	82.738.02	165	83.031.06	34	83.277.01	170	83.339.02	178
82.410.02	143	82.580.10	154	82.738.03	165	83.031.07	34	83.277.03	170	83.340.22	178
82.410.03	143	82.580.11	154	82.738.04	165	83.031.08	34	83.277.10	170	83.344.01	179
82.414.01	143	82.580.90	154	82.738.05	165	83.033.01	34	83.282.02	171	83.345.01	179
82.414.02	143	82.580.91	154	82.738.06	165	83.033.02	34	83.283.02	171	83.346.01	179
82.414.03	143	82.580.99	154	82.738.07	165	83.033.03	34	83.290.02	174	83.346.02	180
82.414.04	143	82.581.01	153	82.738.08	165	83.033.04	34	83.290.04	174	83.346.10	180
82.501.01	144	82.581.02	153	82.738.09	165	83.033.05	34	83.290.14	174	83.352.02	179
82.501.02	144	82.581.06	153	82.820.10	69	83.033.06	34	83.291.08	174	83.352.08	179
82.501.03	144	82.581.07	153	82.820.20	69	83.033.07	34	83.292.29	171	83.352.10	179
82.505.01	144	82.581.08	153	82.821.01	69	83.033.08	34	83.293.01	171	83.352.11	179
82.505.02	144	82.582.01	151	82.821.02	69	83.037.01	35	83.293.02	171	83.352.12	179
82.505.03	144	82.582.02	151	82.822.10	69	83.037.02	35	83.293.06	174	83.354.00	179
82.508.01	145	82.582.03	151	82.822.20	69	83.037.03	35	83.295.02	174	83.355.00	179
82.508.02	145	82.583.09	151	82.823.01	69	83.037.04	35	83.295.04	174	83.357.02	180
82.508.03	145	82.585.01	152	82.823.02	69	83.037.05	35	83.296.04	171	83.358.02	180
82.508.04	145	82.585.02	152	82.826.10	69	83.037.06	35	83.308.30	172	83.362.01	181
82.511.00	146	82.585.03	152	82.826.20	69	83.099.01	35	83.308.33	172	83.362.11	181
82.511.01	146	82.587.01	151	82.827.01	69	83.099.03	35	83.312.02	171	83.363.03	181
82.511.02	146	82.590.04	152	82.827.02	69	83.099.05	35	83.312.03	171	83.363.04	181
82.512.00	146	82.590.05	152	82.828.10	69	83.101.01	35	83.312.07	171	83.363.05	181
82.512.01	146	82.590.06	152	82.828.20	69	83.101.02	35	83.312.13	171	83.363.06	181
82.512.02	146	82.600.18	156	82.829.01	69	83.101.03	35	83.312.14	171	83.391.02	182
82.513.00	146	82.600.22	156	82.829.02	69	83.101.04	35	83.315.07	173	83.391.06	182
82.513.01	146	82.601.18	156	82.851.01	70	83.101.05	35	83.315.10	173	83.391.08	182
82.513.02	146	82.601.22	156	82.859.10	70	83.101.06	35	83.315.11	173	83.391.09	182
82.514.00	146	82.602.18	158	82.859.11	70	83.103.01	36	83.316.02	173	83.391.10	182
82.514.01	146	82.602.22	158	82.863.00	70	83.103.02	36	83.316.03	173	83.391.66	182
82.514.02	146	82.603.18	159	82.863.00	70	83.103.03	36	83.316.19	173	83.392.05	184
82.515.00	146	82.603.22	159	82.863.10	70	83.103.04	36	83.317.10	173	83.394.01	182
82.515.01	146	82.603.51	156	82.863.11	70	83.103.05	36	83.326.01	175	83.394.06	182
82.515.02	146	82.603.52	156	82.871.11	71	83.103.06	36	83.326.02	175	83.394.08	182
82.525.01	147	82.606.18	158	82.871.11R	71	83.107.01	36	83.326.03	175	83.397.14	182
82.525.02	147	82.606.22	158	82.871.22R	71	83.107.02	36	83.326.04	175	83.397.54	182
		82.608.18	157	82.871.33	71	83.107.03	36	83.326.05	175	83.397.55	182
				82.871.33	71	83.107.04	36	83.326.06	175	83.397.65	182

83

84

83.399.01	185	83.504.13	190	84.251.06	197	84.361.11	201	84.485.06	206	86.366.00	219
83.401.01	183	83.511.08	189	84.251.07	197	84.361.12	201	84.485.07	206	86.370.30	219
83.401.02	183	83.524.13	190	84.251.08	197	84.361.13	201	84.500.16	207	86.370.31	219
83.401.03	183	83.525.13	190	84.251.09	197	84.361.14	201	84.502.15	207	86.392.01	220
83.401.05	183			84.261.01	197	84.361.15	201	84.505.17	207	86.394.01	220
83.401.06	183			84.261.02	197	84.361.16	201	84.506.16	207	86.395.01	220
83.401.07	183			84.261.03	197	84.361.17	202	84.513.17	207	86.401.01	220
83.401.08	183	84.141.00	192	84.261.04	197	84.361.18	202	84.514.00	208	86.402.01	220
83.401.23	183	84.141.10	192	84.261.05	197	84.361.19	202	84.515.26	208	86.403.01	220
83.401.42	183	84.141.11	192	84.270.10	198	84.361.20	202	84.515.27	208	86.410.01	220
83.405.03	183	84.141.12	192	84.270.20	198	84.361.21	202	84.515.28	208	86.416.01	221
83.405.06	183	84.141.13	192	84.270.30	198	84.361.22	202	84.515.29	208	86.424.01	221
83.405.23	183	84.151.10	192	84.270.31	198	84.361.23	202	84.515.30	208	86.425.01	221
83.405.54	183	84.151.20	192	84.270.40	198	84.361.24	202	84.515.31	208	86.428.01	221
83.421.02	184	84.151.30	192	84.270.41	198	84.361.25	202	84.515.51	208	86.435.01	221
83.421.05	184	84.151.40	192	84.270.42	198	84.361.26	202	84.515.60	208	86.435.02	221
83.421.09	184	84.151.50	192	84.270.50	198	84.361.27	202			86.435.06	221
83.439.16	185	84.151.51	192	84.270.51	198	84.361.29	202			86.435.10	222
83.441.17	185	84.151.60	192	84.270.52	198	84.361.30	202			86.436.00	222
83.442.03	185	84.151.70	192	84.270.60	198	84.361.31	202	86.101.00	210	86.462.01	222
83.443.03	185	84.152.07	193	84.270.70	198	84.361.32	202	86.101.01	210	86.462.02	222
83.444.02	185	84.163.00	193	84.270.71	198	84.361.33	202	86.101.02	210	86.465.01	222
83.446.17	186	84.165.00	193	84.270.72							

87.556.11	226	87.836.15	245
87.563.11	227	87.852.00	244
87.563.12	227	87.852.01	244
87.564.12	227	87.852.02	244
87.572.11	227	87.853.00	244
87.572.12	227	87.901.12	239
87.574.15	227	87.904.07	239
87.604.13	228	87.912.12	239
87.606.13	228	87.920.12	239
87.608.13	228	87.924.05	239
87.612.14	228	87.947.04	239
87.616.14	228		
87.620.12	229	88	
87.624.17	228		
87.626.16	229	88.118.50	241
87.632.15	229	88.118.65	241
87.650.12	229	88.118.75	241
87.651.12	229	88.121.65	242
87.654.13	229	88.121.69	242
87.660.13	230	88.121.70	242
87.661.14	230	88.290.01	240
87.662.14	230	88.290.04	240
87.663.00	230	88.290.05	240
87.663.02	230	88.650.01	240
87.664.14	230	88.650.02	240
87.666.14	231	88.650.03	240
87.667.12	231	88.695.01	241
87.668.14	231	88.695.02	241
87.672.12	231	88.695.03	241
87.674.13	231	88.698.00	241
87.678.13	232	88.698.38	241
87.679.13	232	88.698.39	241
87.690.15	232		
87.694.15	232	90	
87.697.15	232		
87.702.15	236	90.010.01	248
87.703.12	215	90.010.02	248
87.703.15	215	90.010.11	248
87.705.15	233	90.010.12	248
87.707.15	233	90.010.13	248
87.709.15	233	90.010.33	248
87.710.13	233	90.066.02	249
87.711.14	234	90.066.04	249
87.713.14	234	90.066.06	249
87.714.05	234		
87.740.16	216		
87.742.12	235		
87.744.14	235		
87.750.14	216		
87.751.14	216		
87.754.00	216		
87.754.12	216		
87.757.18	214		
87.760.14	215		
87.770.14	235		
87.771.13	236		
87.776.12	235		
87.780.14	235		
87.783.12	235		
87.785.14	236		
87.788.13	236		
87.794.13	236		
87.796.13	234		
87.797.13	234		
87.798.00	236		
87.816.10	245		
87.834.15	245		

24

INHALTSVERZEICHNIS

ALPHABETIC INDEX
 INDEX ALPHABÉTIQUE
 ÍNDICE ALFABÉTICO
 INDICE ALFABETICO

A

ABDRUCKLÖFFEL	210
ABELL	236
ACORN	196
ADAMS	90,229
ADERER	231,233
ADSON	4,28,65
ADSON MICRO	28
AINSWORTH	207
ALBRECHT	138
ALLIS	44
ALLIS-BABY	44
ALM	52
AMALGAMINSTRUMENTE	195
AMALGAMSTOPFER	192
AMPULLENSPRITZEN	156
ANDRESEN	229
ANGLE	229,232,234
ANTKOVIK	213
APICAL	142,144
APICAL-FLOHR	142
ARRUGA	58
ARTERIENKLEMMEN	39
ASH	200
ATRAUMATISCHE PINZETTEN	33

B

BABCOCK	44
BACKHAUS	43
BALDWIN	199
BALL	196
BANDABNEHMEZANGEN	233
BARRY	152
BAUMGARTNER	54
BAUSCH	214
BEALE	222
BEEBEE	24
BENNET	200
BEYER	64
BERNARD	153,154
BLACK	168,192
BOEHM	215
BOLEY	245
BRACKETHALTER	244
BREWER	207
BUNTING	173
BYRD	10,2
BLUMENTHAL	63
BOEHLER	64
BOWDLER-HENRY	51
BOWMAN	82
BROPHY	31
BRUENINGS	84
BUCHWALD	84
BUCK	23

C

CASTROVIEJO-EPKER	245
CASTROVIEJO	59
CAWOOD-MINNESOTA	86
CHEATLE	238
CHIRURGISCHE SCHEREN	12

CHOMPRET	70,153
CLEOIDS-DISCOIDS	181
CLEVELAND	62
COLEMAN	142,144,145,147
COLUMBIA	174
CONTAINER	240
COUPLAND	2
CRANE-COGSWELL	140
CRANE-KAPLAN	172,174
CRILE	41
CRILE-MURRAY	55
CRILE-WOOD	54
CRYER	119,120,136,140
CUMINE	171
CUSHING	30

D

DARBY-PERRY	170,186
DAVIS	238
DEAN	21
DEAVER	14
DE BAKEY	16,33,55
DE LA ROSA	230
DENHARDT	87
DENTIMETER	216
DIDNER	205
DINGMANN	65,88
DOYEN	85
DOYEN-JANSEN (MOLT)	87
DRAHTSCHEREN	24
DRAHTSCHNEIDEZANGEN	227
DUMONT	225,226
DYCAL	198

E

EAMES	193
EINMALSKALPELLE	9
EISELSBERG	23
ELEKTRODEN	248
ELEVATORIEN	75
ELLIOT	193
EXKAVATOREN	186

F

FADENSCHEREN	23
FAHNENSTOCK	213
FARABEUF	46
FERGUSSON	3
FINGERSCHUTZ	90
FISCHER	228
FJELDSTAD	221
FLACHMEISSEL	79
FLACHZANGEN	224
FLAGG	36
FRAHM	219,221,222
FRAZIER	3
FREER	75,79
FRENZEL	84
FREVERT	235
FRIEDMAN	62
FRIEDMAN-MINI	62
FURRER	236

G

GERALD	31
GEWEBEFASSZANGEN	44
GILLES	58
GILLIES	30,47
GIPSSPATEL	212
GISY-WILD	213
GOLDMAN-FOX	22,77,175,180
GORDON	236
GOSLEE	225
GRACEY	176,177
GREEN	49
GRITMAN	213,219,222
GROSS-MAIER	44

H

HALSEY	54
HALSTED-MOSQUITO	40
HÄMMER	66
HANDWASCHBÜRSTE	244
HARRIS	111,112
HARTMANN	84
HAUBEIL	193
HEIDBRINK	151
HEIDEMANN	199
HEISTER	87
HEMINGWAY	71
HENAHAN	108
HIRSCHFELD	173
HOHLMEISSEL	80
HOHLMEISSELZANGEN	62,64
HOLLENBACK	193,194,219
HOW	216
HULL	118
HYGIENIST	171
HYLIN	220

I

IRIS	20
IRISSCHEREN	20
IVORY	195,205,207,208
IWANSON	245

J

JACQUETTE	170,171
JAMESON	18
JAMESON-WERBER	18
JARABAK	230
JENNINGS	87
JOHNSON	236
JOSEPH	15

K

KAY (AUSTIN)	51
KELLY	14,40
KELLY-RANKIN	41
KELLS	117

KILNER	19
KILNER-DOUGHTY	89
KINDERZAH. AMER. FORM	135
KINDERZAH. ENG. FORM	128
KINNHALTER	50
KIRKLAND	178
KLAMMERBIEGEZANGEN	231
KLEIN	128,134
KNOCHENFEILEN	73
KNOCHENHALTEZANGEN	65
KNOPFSONDEN	82
KOCHER-LANGENBECK	49
KOEHLER	231
KOFFERDAM-INSTRUMENTE	207
KÖHLERT-WHITE	105
KONTURZANGEN	235
KORKHAUS	234
KRAMPONZANGEN	232
KRONENABNEHMER	215
KRONENINSTRUMENTE	214
KRONENSETZER	214
KÜRETTEN	174

L

LAGERUNGSTRAY	241
LANDGRAF	37
LANDMORE	197
LANGBECK	224,226
LANGE	185
LANGENBECK	48,90
LANGER	174
LAWRENCE-READ	134
LECLUSE	148
LE CRON	220
LESSMANN	213
LEXER-FINO	16
LEXER-MINI	80
LICHTENSTEIN	212
LIGATURZANGEN	234
LINSEMAN	199
LISTER	26
LITTAUER	23
LOCKLIN	21
LONDON-COLLEGE	34,35
LUCAS	72
LUER	4,63
LUKS	189
LUNIATSCHEK	90

M

MATRIZEN	206
MATRIZENSPANNER	205
MAYO-HEGAR	55
MARKIERPINZETTEN	38
MARTINI	68,70
MATHIEU	56,57
MCCALL	170,171
MCKELLOPS	228
MCKELLOPS-STADLER	229
MCKESSON	90,140,146
MEAD	72,66,63

MERIAM	35
MERSHON	214
MESSER	5
METZENBAUM	16
METZENBAUM-FINO	17
MIDDELDORFF	49
MIKROCONTAINER	240
MIKRO-NADELHALTER	60
MIKROSCHEREN	25
MIKRO SKALPELLKLINGEN	10
MILCHZAHNPINZETTEN	138
MILLER	140,141,214,215
MILLER-APEXO	140,141
MILLER-COLBURN	73,74
MILWAUKEE	109
MITCHELL	171
MOD.PARIS	216
MOESLE	199
MOLT	72,78
MONFORT	216
MORRISON	126
MUEHLEMANN	168
MUNDSPERRER	87,88
MUNDSPIEGEL	162

N

NABERS	180
NADELHALTER	54
NAHTPINZETTEN	32
NANCE	236
NASENFLÜGELHÄKCHEN	47
NERVKANALERWEITERER	190
NERVKANALSTOPFER	189
NERVKANALZANGEN	190
NERV-PRÄPARIERSCHERE	18
NEVIUS	117
NORTHBENT	23
NYSTROEM	205

O

OBWEGESER	50
OHL	76
OLIVER	233
OLIVER-JONES	233
OLSEN-HEGAR	57
ORBAN	178

P

PALMER	207
PARKER	10
PARODONTALFEILE	173
PARODONTOLOGIE	178
PARODONTOMETRIE	179,180
PARTSCH	80
PEAN	42
PEESO	235
PEET	32
PERRY	37
PHYSICK	110
PINZETTEN	27

P. K. THOMAS	217
PLESTER	4
POLIERINSTRUMENTE	196
POTT	148
PRÄPARIERSCHEREN	18
PRICHARD	172
PROVIDENCE-HOSPITAL	42

R

RASPATORIEN	76
REINIGUNGSSINSTRUMENTE	168
REYNOLD	235
REYNOLDS	19
RIEGNER	221
ROACH	221
ROGGE	238
ROUTURIER	106
RYDER	56
RYDER VASCULAR	56
ROCHESTER-OCHSNER	43
ROCHESTER-PEAN	42
ROSER-KOENIG	87
ROUX	46
RUSKIN	64

S

SACHS	214
SANVENERO	15
SAUGKANÜLEN	3
SAUGROHRE	2
SCHAEDEL	43
SCHARFE LÖFFEL	68
SCHARMANN	170
SCHEREN	11
SCHLAUFENBIEGEZANGEN	229
SCHLUGER	173
SCHMELZMEISSEL	188
SCHURE	214
SCHWARZ	212,228
SELDIN	74,76
SEMKEN	30
SENN	46
SERVETTENHALTER	90
SHORTBENT	23
SICHEL	170
SIMPLEX	86
SMITH	199
SPIRITUSLAMPEN	239
STADLER	229
STERILISATIONSSINSTRUMENTE	238
SUGARMAN	173
SYNDESMOTOME	153
SKALPELLE	5
SKALPELLGRIFFE	6
SPENCER	23
SPLITTERZANGEN	32
STERILE SKALPELLKLINGEN	6
STERNBERG	86
STEVENS	58
STIEGLITZ	32
STRANDELL-STILLE	47

T

TANNER	181,188
TAYLOR	31,171
TAMPONSTOPFER	90
THOMAS	116
THUERRIEGEL	189
TOBOLD	85
TOENNIS	56
TOENNIS-ADSON	19
TOENNIS-ADSON FINO	19
TOFFLEMIRE	205
TOWNER-JACQUETTE	172
TREYMAN	215
TRIPLEX	235
TRYFUS	216
TUCHKLEMMEN	43
TWEED	230

U

UHRMACHERPINZETTE	32
UNIVERSAL	24,26,232,238

V

VEHE	220
VERBANDSSCHEREN	26
VIRTUS (RALK)	32
VOLKMANN	47, 68

W

WACHSMESSER	213
MODELLIERINSTRUMENTE	217
WAERHAUG	219
WAGNER	22
WAKEFILED	79
WALDSACHS-UNIVERSAL	232
WANGENHALTER	51,86
WARD	51,219
WARWICK-JAMES	143,145,147
WEINGART	234
WEITLANER	52
WEST-APIVCAL	151
WESTCOTT	194
WEST HEIDBRINK-APIVCAL	151
WESTON	222
W. F. BARRY	149
WHITE	183,187,196,200
WIEDER	84
WILLIAM-FOX	180
WILLIAMS	199
WILLIGER	48,66,68,69,75,77,168
WINTER	150,152
WOOD	104
WOODSON	199,200
WOOD-WARD	109
WUNDHAKEN	45
WUNDSPREIZER	52
WURZELHEBER	140
WURZELSCHRAUBEN	126
WURZELSPITZENHEBER	151

Y

YOUNG	230
YOUNGER-GOOD	171,174

Z

ZAHLE	220
ZAHNFLEISCHSCHEREN	21
ZAHNPINZETTEN	34
ZAHNSONDEN	182,184
ZAHNZANGEN, AMERI. FORM	108
ZAHNZANGEN, ENGLISCHE FORM	92
ZEMENTSPATEL	203
ZUNGENDRÜCKER	88
ZUNGENSPEL	84
ZUNGENZANGEN	89

E

INHALTSVERZEICHNIS

ALPHABETIC INDEX
INDEX ALPHABÉTIQUE
ÍNDICE ALFABÉTICO
INDICE ALFABETICO

A

ABELL	236
ACORN	196
ADAMS	90,229
ADERER	231,233
ADSON	4,28,65
ADSON MICRO	28
AINSWORTH	207
ALAR HOOKLET	47
ALBRECHT	138
ALLIS	44
ALLIS-BABY	44
ALM	52
AMALGAM INSTRUMENTS	195
AMALGAM PLUGGER	192
ANDRESEN	229
ANGLE	229,232,234
ANTKOVIK	213
APICAL	142,144
APICAL-FLOHR	142
ARRUGA	58
ARTICULATING PAPER FORCEPS	214
ASH	200
ATRAUMATIC TISSUE FORCEPS	33

B

BABCOCK	44
BACKHAUS	43
BALDWIN	199
BALL	196
BANDAGE SCISSORS	26
BAND REMOVING PLIERS	233
BARRY	152
BAUMGARTNER	54
BAUSCH	214
BEALE	222
BEEBEE	24
BENNET	200
BEYER	64
BERNARD	153,154
BLACK	168,192
BOEHM	215
BOLEY	245
BONE CURETTES	68
BONE FILES	73
BONE HOLDING FORCEPS	65
BONE RONGEURS	62
BRACKET HOLDER	244
BREWER	207
BUNTING	173
BURNISHERS	196
BYRD	10,2
BLUMENTHAL	63
BOEHLER	64
BOWDLER-HENRY	51
BOWMAN	82
BROPHY	31
BRUENINGS	84
BUCHWALD	84
BUCK	23

C

CASTROVIEJO-EPKER	245
CASTROVIEJO	59
CAWOOD-MINNESOTA	86
CEMENT SPATULAS	203
CHEATLE	238
CHEEK RETRACTORS	51,86
CHIN RETRACTOR	50
CHISELS	79
CHISELS AND GOUGES	80
CHOMPRET	70,153
CLELAND	62
CLEOIDS-DISCOIDS	181
COLEMAN	142,144,145,147
COLUMBIA	174
CONTAINERS	240
CONTOURING PLIERS	235
COUPLAND	2
CRANE-COGSWELL	140
CRANE-KAPLAN	172,174
CRILE	41
CRILE-MURRAY	55
CRILE-WOOD	54
CROWN REMOVER	215
CROWN SETTER	214
CROWN SPLITTER	216
CRYSER	119,120,136,140
CUMINE	171
CURETTES	174
CUSHING	30

D

DARBY-PERRY	170,186
DAVIS	238
DEAN	21
DEAVER	14
DE BAKEY	16,33,55
DE LA ROSA	230
DENHARDT	87
DENTAL EXPLORERS	182
DENTAL TWEEZERS	34
DENTIMETER	216
DIDNER	205
DINGMANN	65,88
DISPOSABLE SCALPELS	9
DISSECTING FORCEPS	28
DISSECTING SCISSORS	16
DOYEN	85
DOYEN-JANSEN (MOLT)	87
DUMONT	225,226
DYCAL	198

E

EAMES	193
EISELSBERG	23
ELECTRODES	248
ELEVATORS	75
ELLIOT	193
ENAMEL CHISELS	188
EXCAVATORS	186

EXTRA. FORCEPS, AME. PATTERN	108
EXTRA. FORCEPS, ENG. PATTERN	92
EXTRACTING FORCEPS FOR CHILDREN	
ENGLISH PATTERN	128
EXTRACTING FORCEPS FOR CHILDREN	
AMERICAN PATTERN	135

F

FAHNENSTOCK	213
FARABEUF	46
FERGUSON	3
FINGER PROTECTOR	90
FISCHER	228
FJELDSTAD	221
FLAGG	36
FLAT NOSE PLIERS	224
FORCEPS FOR DECIDUOUS TEETH	138
FRAHM	219,221,222
FRAZIER	3
FREER	75,79
FRENZEL	84
FREVERT	235
FRIEDMAN	62
FRIEDMAN-MINI	62
FURRER	236

G

GAUZE PACKER	90
GERALD	31
GILLES	58
GILLIES	30,47
GISY-WILD	213
GOLDMAN-FOX	22,77,175,180
GORDON	236
GOSLEE	225
GRACEY	176,177
GREEN	49
GRITMAN	213,219,222
GROSS-MAIER	44
GUM SCISSORS	21

H

HALSEY	54
HALSTED-MOSQUITO	40
HAND BRUSH	244
HARRIS	111,112
HARTMANN	84
HAUBEIL	193
HEIDBRINK	151
HEIDEMANN	199
HEISTER	87
HEMINGWAY	71
HEMOSTATIC FORCEPS	40
HENAHAN	108
HIRSCHFELD	173
HOLLENBACK	193,194,219
HOW	216
HULL	118
HYGIENIST	171
HYLIN	220

I

IMPRESSION TRAYS	210
IRIS	20
IRIS SCISSORS	20
IVORY	195,205,207,208
IWANSON	245

J

JACQUETTE	171
JAMESON	18
JAMESON-WERBER	18
JAQUETTE	170
JARABAK	230
JENNINGS	87
JOHNSON	236
JOSEPH	15

K

KAY (AUSTIN)	51
KELLY	14,40
KELLY-RANKIN	41
KELLS	117
KILNER	19
KILNER-DOUGHTY	89
KIRKLAND	178
KLEIN	128,134
KNIVES	5
KOCHER-LANGENBECK	49
KOEHLER	231
KÖHLERT-WHITE	105
KORKHAUS	234

L

LANDGRAF	37
LANDMORE	197
LANGBECK	224,226
LANGE	185
LANGENBECK	48,90
LANGER	174
LAWRENCE-READ	134
LECLUSE	148
LE CRON	220
LESSMANN	213
LEXER-FINO	16
LEXER-MINI	80
LICHTENSTEIN	212
LIGATURE PLIERS	234
LINSEMAN	199
LISTER	26
LITTAUER	23
LOCKLIN	21
LONDON-COLLEGE	34,35
LOOP FORMING PLIERS	229
LUCAS	72
LUER	4,63
LUKS	189
LUNIATSCHEK	90

M

MALLETS	66
MATRIX BANDS	206
MATRIX RETAINERS	205
MAYO-HEGAR	55
MARTINI	68,70
MATHIEU	56,57
MCCALL	170,171
MCKELLOPS	228
MCKELLOPS-STADLER	229
MCKESSON	90,140,146
MEAD	63,66,72
MERIAM	35
MERSHON	214
METZENBAUM	16
METZENBAUM-FINO	17
MICRO CONTAINERS	240
MICRO NEEDLE HOLDERS	59
MICRO SCALPEL BLADES	10
MICRO SCALPEL HANDLES	10
MICRO SCISSORS	25
MIDDELDORFF	49
MILLER	140,141,214,215
MILLER-APEXO	140,141
MILLER-COLBURN	73,74
MILWAUKEE	109
MITCHELL	171
MODELLING CARVERS	181,217
MOD.PARIS	216
MOESLE	199
MOLT	72,78
MONFORT	216
MORRISON	126
MOUTH GAGS	87
MOUTH MIRRORS	162
MUEHLEMANN	168

N

NABERS	180
NANCE	236
NAPKIN HOLDER	90
NEEDLE HOLDERS	54
NERVE DISSECTING SCISSORS	18
NEVIUS	117
NORTHBENT	23
NYSTROEM	205

O

OBWEGESER	50
OHL	76
OLIVER	233
OLIVER JONES	233
OLSEN-HEGAR	57
OPERATING SCISSORS	12
ORBAN	178

P

PALMER	207
PARKER	10
PARODONTOMETER	179

PARTSCH	80
PEAN	42
PEESO	235
PEET	32
PERIODONTAL FILE	173
PERIODONTOLOGY	178
PERIOSTEAL ELEVATORS	76
PERRY	37
PHYSICK	110
P. K. THOMAS	217
PLASTER SPATULAS	212
PLASTIC FILLING INSTRUMENTS	197
PLESTER	4
POCKET MARKERS	38
POTT	148
PRICHARD	172
PROBES	82
PROVIDENCE-HOSPITAL	42

R

RETRACTORS	46
REYNOLD	235
REYNOLDS	19
RIEGNER	221
ROACH	221
ROGGE	238
ROOT CANAL FORCEPS	190
ROOT CANAL PLUGGERS	189
ROOT CANAL SPREADERS	190
ROOT ELEVATORS	140
ROOT FRAGMENT ELEVATORS	151
ROOT SCREWS	126
ROUTURIER	106
RUBBERDAM CLAMP FORCEPS	207
RUBBERDAM INSTRUMENTS	207
RUBBERDAM PUNCH FORCEPS	207
RYDER	56
RYDER VASCULAR	56
ROCHESTER-OCHSNER	43
ROCHESTER-PEAN	42
ROSER-KOENIG	87
ROUX	46
RUSKIN	64

S

SACHS	214
SANVENERO	15
SCALERS	168
SCALPEL HANDLES	6
SCALPELS	5
SCHAEDEL	43
SCHARMANN	170
SCHLUGER	173
SCHURE	214
SCHWARZ	212,228
SCISSORS	11
SELDIN	74,76
SELF-RETAINING RETRACTORS	52
SEMKEN	30
SENN	46
SHORTBENT	23
SICHEL	170
SIMPLEX	86

SMITH	199
SPIRIT LAMPS	239
SPLINTER FORCEPS	32
STADLER	229
STERILE SCALPEL BLADES	6
STERILIZATION INSTRUMENTS	238
STORAGE TRAY	241
SUCTION CANNULA	3
SUCTION TUBES	2
SUGARMAN	173
SUTURING FORCEPS	32
SPENCER	23
STERNBERG	86
STEVENS	58
STIEGLITZ	32
STRANDELL-STILLE	47
SYNDESMOTOMES	153

T

TANNER	181,188
TAYLOR	31,171
THOMAS	116
THUERRIEGEL	189
TISSUE GRASPING FORCEPS	44
TOBOLD	85
TOENNIS	56
TOENNIS-ADSON	19
TOENNIS-ADSON FINO	19
TOFFLEMIRE	205
TONGUE DEPRESSOR	88
TONGUE DEPRESSORS	84
TONGUE HOLDING FORCEPS	89
TOWEL CLAMPS	43
TOWNER-JACQUETTE	172
TREYMAN	215
TRIPLEX	235
TRYFUS	216
TWEED	230

U

UNIVERSAL	24,26,232,238
UNIVERSAL BENDING PLIERS	232

V

VEHE	220
VIRTUS (RALK)	32
VOLKMANN	47,68

W

WAERHAUG	219
WAGNER	22
WAKEFILED	79
WALDSACHS-UNIVERSAL	232
WARD	51,219
WARWICK-JAMES	143,145,147
WATCHMAKER FORCEP	32
WAX KNIFES	213
WEINGART	234
WEITLANER	52
WEST-APIVCAL	151
WESTCOTT	194
WEST HEIDBRINK-APIVCAL	151
WESTON	222
W. F. BARRY	149
WHITE	183,187,196,200
WIEDER	84
WILLIAM-FOX	180
WILLIAMS	199
WILLIGER	48,66,68,69,75,77,168
WINTER	150,152
WIRE CUTTERS	227
WIRE CUTTING SCISSORS	24
WOOD	104
WOODSON	199,200
WOOD-WARD	109

Y

YOUNG	230
YOUNGER-GOOD	171,174

Z

ZAHLE	220
-------	-----

F

INHALTSVERZEICHNIS

ALPHABETIC INDEX
INDEX ALPHABÉTIQUE
ÍNDICE ALFABÉTICO
INDICE ALFABETICO

A

ABAISSE-LANGUE	84
ABELL	236
ACORN	196
ADAMS	90,229
ADERER	231,233
ADSON	4,28,65
ADSON MICRO	28
AINSWORTH	207
AJUSTEUR DE COURONNES	214
ALBRECHT	138
ALLIS	44
ALLIS-BABY	44
ALM	52
ANDRESEN	229
ANGLE	229,232,234
ANTKOVIAK	213
APICAL	142,144
APICAL-FLOHR	142
ARRUGA	58
ASH	200

B

BABCOCK	44
BACINELLE À STOCKAGE	241
BACKHAUS	43
BALDWIN	199
BALL	196
BARRY	152
BAUMGARTNER	54
BAUSCH	214
BEALE	222
BEEBEE	24
BENNET	200
BEYER	64
BERNARD	153,154
BISTOURIS À USAGE UNIQUE	9
BLACK	168,192
BOEHM	215
BOLEY	245
BONE RONGEURS	62
BREWER	207
BROSSE À MAINS	244
BRUNISSOIRS	196
BUNTING	173
BYRD	10,2
BLUMENTHAL	63
BOEHLER	64
BOWDLER-HENRY	51
BOWMAN	82
BROPHY	31
BRUENINGS	84
BUCHWALD	84
BUCK	23

C

CANULES D'ASPIRATION	3
CASTROVIEJO-EPKER	245
CASTROVIEJO	59
CAWOOD-MINNESOTA	86
CHEATLE	238
CHOMPRET	70,153

CISEAUX	11
CISEAUX À BANDAGES	26
CISEAUX À CHIRURGIE	12
CISEAUX À COUPER DU FIL DE FER	24
CISEAUX À DISSECTION	16
CISEAUX À ÉMAIL	188
CISEAUX À GENCIVES	21
CISEAUX À IRIDECTOMIE	20
CISEAUX À LIGATURE	23
CISEAUX À PRÉPARATION DE NERF	18
CISEAUX-BURINS ET GOUGES	79
CLEOIDS-DISCOIDS	181
CLEVELAND	62
COLEMANN	142,144,145,147
COLUMBIA	174
CONTENEURS	240
COUPLAND	2
COUTEAUX À CIRE	213
CRANE-COGSWELL	140
CRANE-KAPLAN	172,174
CRILE	41
CRILE-MURRAY	55
CRILE-WOOD	54
CROCHET POUR AILES DE NEZ	47
CRYER	119,120,136,140
CUMINE	171
CURETTES	174
CURETTES TRANCHANTES	68
CUSHING	30

D

DARBY-PERRY	170,186
DAVIERS À OS	65
DAVIERS, FORME AMÉRICAINNE	108
DAVIERS, FORME ANGLAISE	92
DAVIERS ENFANTS, F. AMÉRICAINNE	135
DAVIERS ENFANTS, F. ANGLAISE	128
DAVIS	238
DEAN	21
DEAVER	14
DE BAKEY	16,33,55
DE LA ROSA	230
DENHARDT	87
DENTIMÈTRE	216
DIDNER	205
DINGMANN	65,88
DOIGTIERS	90
DOYEN	85
DOYEN-JANSEN (MOLT)	87
DUMONT	225,226
DYCAL	198

E

EAMES	193
ÉCARTEURS	46
ÉCARTEURS AUTOSTATIQUES	52
ÉCARTEURS DE JOUES	51
ECARTEURS DES JOUES	86
EISELSBERG	23
ÉLARGISSEURS DE CANAL	190
ÉLECTRODES	248
ELÉVATEURS	75
ELÉVATEURS DE RACINES	140

ELÉVATEURS POUR FRAGMENT	151
ELLIOT	193
EXCAVATEURS	186
EXTRACTEUR DE COURONNES	215

F

FAHNENSTOCK	213
FARABEUF	46
FERGUSSON	3
FISCHER	228
FJELDSTAD	221
FLAGG	36
FOULOIRS À AMALGAME	192
FRAHM	219,221,222
FRAZIER	3
FREER	75,79
FRENZEL	84
FREVERT	235
FRIEDMAN	62
FRIEDMAN-MINI	62
FURRER	236

G

GERALD	31
GILLES	58
GILLIES	30,47
GISY-WILD	213
GOLDMAN-FOX	22,77,175,180
GORDON	236
GOSLEE	225
GRACEY	176,177
GREEN	49
GRITMAN	213,219,222
GROSS-MAIER	44

H

HALSEY	54
HALSTED-MOSQUITO	40
HARRIS	111,112
HARTMANN	84
HAUBEIL	193
HEIDBRINK	151
HEIDEMANN	199
HEISTER	87
HEMINGWAY	71
HENAHAN	108
HIRSCHFELD	173
HOLLENBACK	193,194,219
HOW	216
HULL	118
HYGIENIST	171
HYLIN	220

I

INSTRUMENTES POUR AMALGAME	195
INSTRUMENTS À DÉTARTREUR	168
INSTRUMENTS À MODELER	181,217
INSTRUMENTS DE STÉRILISATION	238
INSTRUMENTS POUR COURONNES	214
INSTRUMENTS POUR CRAMPONS	207
INSTRUMENTS POUR PLOMBAGES	197

IRIS	20
IVORY	195,205,207,208
IWANSON	245

J

JACQUETTE	171
JAMESON	18
JAMESON-WERBER	18
JAQUETTE	170
JARABAK	230
JENNINGS	87
JOHNSON	236
JOSEPH	15

K

KAY (AUSTIN)	51
KELLY	14,40
KELLY-RANKIN	41
KELLS	117
KILNER	19
KILNER-DOUGHTY	89
KIRKLAND	178
KLEIN	128,134
KOCHER-LANGENBECK	49
KOEHLER	231
KÖHLERT-WHITE	105
KORKHAUS	234

L

LAMES DE BISTOURI STÉRILES	6
LAMPES À ALCOOL	239
LANDGRAF	37
LANDMORE	197
LANGBECK	224,226
LANGE	185
LANGENBECK	48,90
LANGER	174
LAWRENCE-READ	134
LECLUSE	148
LE CRON	220
LESSMANN	213
LEXER-FINO	16
LEXER-MINI	80
LICHTENSTEIN	212
LIME PARODONTALE	173
LIMES À OS	73
LINSEMAN	199
LISTER	26
LITTAUER	23
LOCKLIN	21
LONDON-COLLEGE	34,35
LOOP FORMING PLIERS	231
LUCAS	72
LUER	4,63
LUKS	189
LUNIATSCHKEK	90

M

MANCHES DE BISTOURI	6
MARTEAUX	66
MATRICES	206
MAYO-HEGAR	55
MARTINI	68,70
MATHIEU	56
MCCALL	170,171
MCKELLOPS	228
MCKELLOPS-STADLER	229
MCKESSON	90,140,146
MEAD	63,66,72
MERIAM	35
MERSHON	214
METZENBAUM	16
METZENBAUM-FINO	17
MICRO-CISEAUX	25
MICRO CONTENEURS	240
MICRO LAMES DE BISTOURI	10
MICRO MANCHES BISTOURIS	10
MIDDELDORFF	49
MILLER	140,141,214,215
MILLER-APEXO	140,141
MILLER-COLBURN	73,74
MILWAUKEE	109
MIROIRS DENTAIRE	162
MITCHELL	171
MOD.PARIS	216
MOSLE	199
MOLT	72,78
MONFORT	216
MORRISON	126
MUEHLEMANN	168

N

NABERS	180
NANCE	236
NEVIUS	117
NORTHBENT	23
NYSTROEM	205

O

OBTURATEURS DE CANAL	189
OBWEGESER	50
OHL	76
OLIVER	233
OLIVER JONES	233
OLSEN-HEGAR	57
ORBAN	178
OUVRE-BOUCHE	87

P

PALMER	207
PARKER	10
PARODONTOLOGIE	178
PARODONTOMÈTRES	179
PARTSCH	80

PEAN	42
PEESO	235
PEET	32
PERRY	37
PHYSICK	110
PINCE À FENDRE COURONNES	216
PINCE D'HORLOGER	32
PINCES À CHAMPS	43
PINCES À CONTOURE	235
PINCES À DENTS DE LAIT	138
PINCES À DIGUE	207
PINCES À DISSECTION	28
PINCES À ÉCHARDES	32
PINCES À FACONNER	229
PINCES À LIGATURE	234
PINCES À PLIER	228
PINCES À SUTURES	32
PINCES À TISSUS	44
PINCES ATRAUMATIQUES	33
PINCES COUPE-FILS	227
PINCES ENLÈVE BAGUES	233
PINCES-GOUGES	64
PINCES HÉMOSTATIQUES	40
PINCES PERFORATRICES	207
PINCES PLATES	224
PINCES POUR CANAL	190
PINCES POUR MARQUER	38
PINCES TIRE-LANGUES	89
PINCES UNIVERSELLES CRAMPON	232
P. K. THOMAS	217
PLESTER	4
PORTE-AIGUILLES	54
PORTE-AIGUILLES, MICRO	59
PORTE-BRACKET	244
PORTE-EMPREINTES	210
PORTE-MATRICES	205
PORTE-SERVIETTE	90
PORTE-TAMPON	90
POTT	148
PRÉCELLES POUR COTON	34
PRICHARD	172
PROVIDENCE-HOSPITAL	42

R

REYNOLD	235
REYNOLDS	19
RIEGNER	221
ROACH	221
ROGGE	238
ROUTURIER	106
RUGINES RASPATOIRES, RUGINES	76
RYDER	56
RYDER VASCULAR	56
ROCHESTER-OCHSNER	43
ROCHESTER-PEAN	42
ROSER-KOENIG	87
ROUX	46
RUSKIN	64

S

SACHS	214
SANVENERO	15
SCHAEDEL	43
SCHARMANN	170
SCHLUGER	173
SCHURE	214
SCHWARZ	212,228
SELDIN	74,76
SEMKEN	30
SENN	46
SERINGUES POUR AMPOULE	156
SHORTBENT	23
SICHEL	170
SIMPLEX	86
SMITH	199
SONDES BOUTONNÉES	82
SONDES DENTAIRES	182
SPATULES À CIMENT	203
SPATULES À PLÂTRE	212
STADLER	229
SUGARMAN	173
SPENCER	23
STERNBERG	86
STEVENS	58
STIEGLITZ	32
STRANDELL-STILLE	47
SYNDESMOTOMES	153

T

TANNER	181,188
TAYLOR	31,171
THOMAS	116
THUERRIEGEL	189
TOBOLD	85
TOENNIS	56
TOENNIS-ADSON	19
TOENNIS-ADSON FINO	19
TOFFLEMIRE	205
TOWNER-JACQUETTE	172
TREYMAN	215
TRIPLEX	235
TRYFUS	216
TUBES D'ASPIRATION	2
TWEED	230

U

UNIVERSAL	24,26,232,238
-----------	---------------

V

VEHE	220
VIRTUS (RALK)	32
VIS À RACINES	126
VOLKMANN	47,68

W

WAERHAUG	219
WAGNER	22
WAKEFILED	79
WALDSACHS-UNIVERSAL	232
WARD	51,219
WARWICK-JAMES	143,145,147
WEINGART	234
WEITLANER	52
WEST-APIVCAL	151
WESTCOTT	194
WEST HEIDBRINK-APIVCAL	151
WESTON	222
W. F. BARRY	149
WHITE	183,187,196,200
WIEDER	84
WILLIAM-FOX	180
WILLIAMS	199
WILLIGER	48,66,68,69,75,77,168
WINTER	150,152
WOOD	104
WOODSON	199,200
WOOD-WARD	109

Y

YOUNG	230
YOUNGER-GOOD	171,174

Z

ZAHLE	220
-------	-----

ES

INHALTSVERZEICHNIS
ALPHABETIC INDEX
INDEX ALPHABÉTIQUE
ÍNDICE ALFABÉTICO
INDICE ALFABETICO

A

ABAJALENGUA	84,88
ABELL	236
ABREBOCAS	87
ACORN	196
ADAMS	90,229
ADERER	231,233
ADSON	4,28,65
ADSON MICRO	28
AINSWORTH	207
ALBRECHT	138
ALICATES DE PICO PLANO	224
ALICATES PARA CONTORNEAR	235
ALICATES PARA DOBLAR ALAMBRE	228
ALICATES PARA LIGADURAS	234
ALICATES PARA PLIEGUES	229,231
ALICATES PARA QUITAR BANDAS	233
ALICATES UNIVERSALES	232
ALLIS	44
ALLIS-BABY	44
ALM	52
ANDRESEN	229
ANGLE	229,232,234
ANTKOVIK	213
APICAL	142,144
APICAL-FLOHR	142
ARRUGA	58
ASH	200

B

BABCOCK	44
BACKHAUS	43
BALDWIN	199
BALL	196
BARRY	152
BAUMGARTNER	54
BAUSCH	214
BEALE	222
BEEBEE	24
BENNET	200
BEYER	64
BERNARD	153,154
BISTURÍES USO ÚNICO	9
BLACK	168,192
BOEHM	215
BOLEY	245
BREWER	207
BUNTING	173
BYRD	10,2
BLUMENTHAL	63
BOEHLER	64
BOWDLER-HENRY	51
BOWMAN	82
BROPHY	31
BRUENINGS	84
BUCHWALD	84
BUCK	23

C

CÁNULAS PARA ASPIRACIÓN	3
CASTROVIEJO-EPKER	245
CASTROVIEJO	59
CAWOOD-MINNESOTA	86
CEPILLO PARA UÑAS	244
CHEATLE	238
CHOMPRET	70,153
CINCELES	79
CINCELES PARA ESMALTE	188
CINCELES Y GUBIAS	80
CLEOIDS-DISCOIDS	181
CLEVELAND	62
COLEMANN	142,144,145,147
COLUMBIA	174
CONTENEDORES	240
COUPLAND	2
CRANE-COGSWELL	140
CRANE-KAPLAN	172,174
CRILE	41
CRILE-MURRAY	55
CRILE-WOOD	54
CRYER	119,120,136,140
CUBETAS PARA IMPRESIONES	210
CUCHARILLAS CORTANTES	68
CUCHILLOS PARA CERA	213
CUMINE	171
CURETAS	174
CUSHING	30

D

DARBY-PERRY	170,186
DAVIS	238
DEAN	21
DEAVER	14
DE BAKEY	16,33,55
DEDAL	90
DE LA ROSA	230
DENHARDT	87
DENTÍMETRO	216
DIDNER	205
DINGMANN	65,88
DOYEN	85
DOYEN-JANSEN (MOLT)	87
DUMONT	225,226
DYCAL	198

E

EAMES	193
EISELSBERG	23
ELECTRODOS	248
ELEVADORES	75
ELEVADORES PARA FRAG. RAÍCES	151
ELEVADORES PARA RAÍCES	140
ELLIOT	193
ESÁTULAS PARA YESO	212
ESPÁTULAS PARA CEMENTO	203
ESPEJOS DE BOCA	162
EXCAVADORES	186
EXTENDEDORES PARA CANALES	190
EXTRACTOR DE CORONAS	215

F

FAHNENSTOCK	213
FARABEUF	46
FERGUSSON	3
FIJADOR DE CORONAS	214
FISCHER	228
FJELDSTAD	221
FLAGG	36
FÓRCEPS DENTALES PARA NIÑOS	128
FRAHM	219,221,222
FRAZIER	3
FREER	75,79
FRENZEL	84
FREVERT	235
FRIEDMAN	62
FRIEDMAN-MINI	62
FURRER	236

G

GANCHITO PARA ALAS DE NARIZ	47
GERALD	31
GILLES	58
GILLIES	30,47
GISY-WILD	213
GOLDMAN-FOX	22,77,175,180
GORDON	236
GOSLEE	225
GRACEY	176,177
GREEN	49
GRITMAN	213,219,222
GROSS-MAIER	44

H

HALSEY	54
HALSTED-MOSQUITO	40
HARRIS	111,112
HARTMANN	84
HAUBEIL	193
HEIDBRINK	151
HEIDEMANN	199
HEISTER	87
HEMINGWAY	71
HENAHAN	108
HIRSCHFELD	173
HOJAS DE BISTURÍ ESTÉRILES	6
HOLLENBACK	193,194,219
HOW	216
HULL	118
HYGIENIST	171
HYLIN	220

I

INSTRUMENTOS PARA AMALGAMA	195
INSTRUMENTOS PARA CERA	217
INSTRUMENTOS PARA CORONAS	214
INSTRUMENTOS PARA DIQUE	207
INSTRUMENTOS ESTERILIZACIÓN	238
INSTRUMENTOS OBTURACIONE	197
IRIS	20
IVORY	195,205,207,208
IWANSON	245

J

JACQUETTE	171
JAMESON	18
JAMESON-WERBER	18
JAQUETTE	170
JARABAK	230
JENNINGS	87
JERINGAS DE CARTUCHO	156
JOHNSON	236
JOSEPH	15

K

KAY (AUSTIN)	51
KELLY	14,40
KELLY-RANKIN	41
KELLS	117
KILNER	19
KILNER-DOUGHTY	89
KIRKLAND	178
KLEIN	128,134
KOCHER-LANGENBECK	49
KOEHLER	231
KÖHLERT-WHITE	105
KORKHAUS	234

L

LÁMPARAS DE ALCOHOL	239
LANDGRAF	37
LANDMORE	197
LANGBECK	224,226
LANGE	185
LANGENBECK	48,90
LANGER	174
LAWRENCE-READ	134
LECLUSE	148
LE CRON	220
LESSMANN	213
LEXER-FINO	16
LEXER-MINI	80
LICHTENSTEIN	212
LIMA PARODONTAL	173
LIMAS PARA HUESOS	73
LIMPIADORES DE SARRO	168
LINSEMANN	199
LISTER	26
LITTAUER	23
LOCKLIN	21
LONDON-COLLEGE	34,35
LUCAS	72
LUER	4,63
LUKS	189
LUNIATSCHEK	90

M

MANGOS DE BISTURÍ	6
MARTILLOS	66
MATRICES	206
MAYO-HEGAR	55
MARTINI	68,70
MATHIEU	56
MCCALL	170,171

MCKELLOPS	228
MCKELLOPS-STADLER	229
MCKESSON	90,140,146
MEAD	63,66,72
MERIAM	35
MERSHON	214
METZENBAUM	16
METZENBAUM-FINO	17
MICRO CONTENEDORES	240
MICRO HOJAS DE BISTURÍ	10
MICRO MANGOS DE BISTURÍ	10
MIDDELDORFF	49
MILLER	140,141,214,215
MILLER-APEXO	140,141
MILLER-COLBURN	73,74
MILWAUKEE	109
MITCHELL	171
MOD.PARIS	216
MOESLE	199
MOLT	72,78
MONFORT	216
MORRISON	126
MUEHLEMANN	168

N

NABERS	180
NANCE	236
NEVIUS	117
NORTHBENT	23
NYSTROEM	205

O

OBTURADORES PARA AMALGAMA	192
OBTURADORES PARA CANALES	189
OBWEGESER	50
OHL	76
OLIVER	233
OLIVER JONES	233
OLSEN-HEGAR	57
ORBAN	178

P

PALMER	207
PARKER	10
PARODONTÓMETROS	179
PARTSCH	80
PEAN	42
PEESO	235
PEET	32
PERFORADORES PARA DIQUE	207
PERIODONCIA	178
PERIOSTÓTOMOS, LEGRAS	76
PERRY	37
PHYSICK	110
PINZA DE RELOJERO	32
PINZA PARA CANALES	190
PINZA PARA CORTAR CORONAS	216
PINZAS ATRAUMÁTICAS	33
PINZAS DE CAMPO	43
PINZAS DE DISECCIÓN	28
PINZAS DE EXTRACCIÓN, INGLESA	92
PINZAS DE GRAPA PARA DIQUE	207

PINZAS DENTAL	34
PINZAS GUBIAS	62
PINZAS-GUBIAS	64
PINZAS HEMOSTÁTICAS	40
PINZAS PARA DIENTES DE LECHE	138
PINZAS PARA ESPINAS	32
PINZAS PARA HUESOS	65
PINZAS PARA MARCAR	38
PINZAS PAPEL DE ARTICULACIÓN	214
PINZAS PARA SUTURAS	32
PINZAS PARA TEJIDOS	44
PINZAS TIRA-LENGUA	89
PINZE PER ESTRAZIONE, AMERI.	108
PINZE PER ESTRAZIONE BAMBINI	135
PINZE PIEGA FILO	227
P. K. THOMAS	217
PLESTER	4
PORTA-AGUJAS	54
PORTA-AGUJAS, MICRO	59
PORTA BRACKET	244
PORTA MATRICES	205
POTT	148
PRICHARD	172
PROVIDENCE-HOSPITAL	42

R

REYNOLD	235
REYNOLDS	19
RIEGNER	221
ROACH	221
ROGGE	238
ROUTURIER	106
RYDER	56
RYDER VASCULAR	56
ROCHESTER-OCHSNER	43
ROCHESTER-PEAN	42
ROSER-KOENIG	87
ROUX	46
RUSKIN	64

S

SACHS	214
SANVENERO	15
SCHAEDEL	43
SCHARMANN	170
SCHLUGER	173
SCHURE	214
SCHWARZ	212,228
SELDIN	74,76
SEMKEN	30
SENN	46
SEPARADORES	46
SEPARADORES AUTOESTÁTICOS	52
SEPARADORES PARA MEJILLAS	51,86
SEPARADOR PARA MENTÓN	50
SERVILLETTERO	90
SHORTBENT	23
SICHEL	170
SIMPLEX	86
SINDESMÓTOMOS	153
SMITH	199
SONDAS ABOTONADAS	82
SONDAS DENTALES	182

STADLER	229
SUGARMAN	173
SPENCER	23
STERNBERG	86
STEVENS	58
STIEGLITZ	32
STRANDELL-STILLE	47

T

TALLADORES PARA MODELAR	181
TANNER	181,188
TAPONEADOR	90
TAYLOR	31,171
THOMAS	116
THUERRIEGEL	189
TIJERAS	11
TIJERAS DE DISECCIÓN	16
TIJERAS MICROQUIRÚRGICAS	25
TIJERAS PARA CIRUGÍA	12
TIJERAS CORTAR HILOS DE ACERO	24
TIJERAS PARA ENCÍAS	21
TIJERAS PARA IRIDECTOMÍA	20
TIJERAS PARA LIGADURA	23
TIJERAS PREPARACIÓN DEL NERVI	18
TIJERAS PARA VENDAJES	26
TOBOLD	85
TOENNIS	56
TOENNIS-ADSON	19
TOENNIS-ADSON FINO	19
TOFFLEMIRE	205
TORNILLOS PARA RAÍCES	126
TOWNER-JACQUETTE	172
TRAY PARA DEPOSITAR	241
TREYMAN	215
TRIPLEX	235
TRYFUS	216
TUBOS DE ASPIRACIÓN	2
TWEED	230

U

UNIVERSAL	24,26,232,238
-----------	---------------

V

VEHE	220
VIRTUS (RALK)	32
VOLKMANN	47, 68

W

WAERHAUG	219
WAGNER	22
WAKEFILED	79
WALDSACHS-UNIVERSAL	232
WARD	51,219
WARWICK-JAMES	143,145,147
WEINGART	234
WEITLANER	52
WEST-APIVCAL	151
WESTCOTT	194
WEST HEIDBRINK-APIVCAL	151
WESTON	222
W. F. BARRY	149
WHITE	183,187,196,200
WIEDER	84
WILLIAM-FOX	180
WILLIAMS	199
WILLIGER	48,66,68,69,75,77,168
WINTER	150,152
WOOD	104
WOODSON	199,200
WOOD-WARD	109

Y

YOUNG	230
YOUNGER-GOOD	171,174

Z

ZAHLE	220
-------	-----

INHALTSVERZEICHNIS
ALPHABETIC INDEX
INDEX ALPHABÉTIQUE
ÍNDICE ALFABÉTICO
INDICE ALFABETICO

A

ABASSALINGUA	88
ABBASSALINGUA	84
ABELL	236
ABLATORI DI TARTARO	168
ACORN	196
ADAMS	90,229
ADERER	231,233
ADSON	4,28,65
ADSON MICRO	28
AINSWORTH	207
ALBRECHT	138
ALLIS	44
ALLIS-BABY	44
ALM	52
ANDRESEN	229
ANGLE	229,232,234
ANTKOVIK	213
APICAL	142,144
APICAL-FLOHR	142
APRIBOCCA	87
ARRUGA	58
ASH	200

B

BABCOCK	44
BACINELLE PER IL DEPOSITO	241
BACKHAUS	43
BALDWIN	199
BALL	196
BARRY	152
BAUMGARTNER	54
BAUSCH	214
BEALE	222
BEEBEE	24
BENNET	200
BEYER	64
BERNARD	153,154
BISTURI USO UNI	9
BLACK	168,192
BOEHM	215
BOLEY	245
BREWER	207
BRUNITORI	196
BUNTING	173
BYRD	10,2
BLUMENTHAL	63
BOEHLER	64
BOWDLER-HENRY	51
BOWMAN	82
BROPHY	31
BRUENINGS	84
BUCHWALD	84
BUCK	23

C

CANNULE PER ASPIRAZIONE	3
CASTROVIEJO-EPKER	245
CASTROVIEJO	59
CAWOOD-MINNESOTA	86
CHEATLE	238
CHIN RETRACTOR	50

CHOMPRET	70,153
CLEOIDS-DISCOIDS	181
CLEVELAND	62
COLEMANN	142,144,145,147
COLTELLI PER CERA	213
COLUMBIA	174
CONTAINER	240
COUPLAND	2
CRANE-COGSWELL	140
CRANE-KAPLAN	172,174
CRILE	41
CRILE-MURRAY	55
CRILE-WOOD	54
CRYER	119,120,136,140
CUMINE	171
CURETTE	174
CURETTE TAGLIENTI	68
CUSHING	30

D

DARBY-PERRY	170,186
DAVIS	238
DEAN	21
DEAVER	14
DE BAKEY	16,33,55
DE LA ROSA	230
DENHARDT	87
DENTIMETRO	216
DIDNER	205
DINGMANN	65,88
DITALE	90
DIVARICATORI	46
DIVARICATORI AUTOSTATICI	52
DOYEN	85
DOYEN-JANSEN (MOLT)	87
DUMONT	225,226
DYCAL	198

E

EAMES	193
EISELSBERG	23
ELETTRODI	248
ELEVATORI	75
ELLIOT	193
ESCAVATORI	186
ESTENSORI TRATTAMENTI CAN.	190
ESTRATTORE PER CORONA	215

F

FAHNENSTOCK	213
FARABEUF	46
FERGUSON	3
FISCHER	228
FISSATORE DE CORONA	214
FJELDSTAD	221
FLAGG	36
FORBICI	11
FORBICI MICRO-CHIRURGICI	25
FORBICI PER BENDAGGI	26
FORBICI PER CHIRURGIA	12
FORBICI PER DISSEZIONE	16
FORBICI PER GENGIVES	21

FORBICI PER IRIDECTOMIA	20
FORBICI PER LEGATURA	23
FORBICI PREPARAZIONE NERVO	18
FORBICI PER TAGILARE	24
FRAHM	219,221,222
FRAZIER	3
FREER	75,79
FRENZEL	84
FREVERT	235
FRIEDMAN	62
FRIEDMAN-MINI	62
FURRER	236

G

GERALD	31
GILLES	58
GILLIES	30,47
GISY-WILD	213
GOLDMAN-FOX	22,77,175,180
GORDON	236
GOSLEE	225
GRACEY	176,177
GREEN	49
GRITMAN	213,219,222
GROSS-MAIER	44

H

HALSEY	54
HALSTED-MOSQUITO	40
HARRIS	111,112
HARTMANN	84
HAUBEIL	193
HEIDBRINK	151
HEIDEMANN	199
HEISTER	87
HEMINGWAY	71
HENAHAN	108
HIRSCHFELD	173
HOLLENBACK	193,194,219
HOW	216
HULL	118
HYGIENIST	171
HYLIN	220

I

IRIS	20
IVORY	195,205,207,208
IWANSON	245

J

JACQUETTE	171
JAMESON	18
JAMESON-WERBER	18
JAQUETTE	170
JARABAK	230
JENNINGS	87
JOHNSON	236
JOSEPH	15

K

KAY (AUSTIN)	51
KELLY	14,40
KELLY-RANKIN	41
KELLS	117
KILNER	19
KILNER-DOUGHTY	89
KIRKLAND	178
KLEIN	128,134
KOCHER-LANGENBECK	49
KOEHLER	231
KÖHLERT-WHITE	105
KORKHAUS	234

L

LAME DA BISTURI STERILI	6
LAMPADE A SPIRITO	239
LANDGRAF	37
LANDMORE	197
LANGBECK	224,226
LANGE	185
LANGENBECK	48,90
LANGER	174
LAWRENCE-READ	134
LECLUSE	148
LE CRON	220
LESSMANN	213
LEVE PER FRAMMENTI DE RADICI	151
LEVE PER RADICI	140
LEXER-FINO	16
LEXER-MINI	80
LICHTENSTEIN	212
LIMA PERIODONTALE	173
LIME PER OSSA	73
LINSEMANN	199
LISTER	26
LITTAUER	23
LOCKLIN	21
LONDON-COLLEGE	34,35
LUCAS	72
LUER	4,63
LUKS	189
LUNIATSCHEK	90

M

MANICI PER BISTURI	6
MARTELLI	66
MATRICI	206
MAYO-HEGAR	55
MARTINI	68,70
MATHIEU	56
MCCALL	170,171
MCKELLOPS	228
MCKELLOPS-STADLER	229
MCKESSON	90,140,146
MEAD	63,66,72
MERIAM	35
MERSHON	214
METZENBAUM	16
METZENBAUM-FINO	17
MICRO CONTAINER	240
MICRO LAME PER BISTURI	10

MICRO MANICI PER BISTUR	10
MIDDELDORFF	49
MILLER	140,141,214,215
MILLER-APEXO	140,141
MILLER-COLBURN	73,74
MILWAUKEE	109
MITCHELL	171
MOD.PARIS	216
MOESLE	199
MOLT	72,78
MONFORT	216
MORRISON	126
MUEHLEMANN	168

N

NABERS	180
NANCE	236
NEVIUS	117
NORTHBENT	23
NYSTROEM	205

O

OBWEGESER	50
OHL	76
OLIVER	233
OLIVER JONES	233
OLSEN-HEGAR	57,58
ORBAN	178
OTTURATORI PER AMALGAMA	192
OTTURATORI TRATTAMENTI CAN.	189

P

PALMER	207
PARKER	10
PARODONTOLOGIA	178
PARODONTOMETRI	179
PARTSCH	80
PEAN	42
PEESO	235
PEET	32
PERIOTOTOMI	76
PERRY	37
PHYSICK	110
PINZE ASPORTABANDE	233
PINZE ATRAUMATICHE	33
PINZE DA OROLOGIAIO	32
PINZE DENTALE	34
PINZE DI CAMPO	43
PINZE EMOSTATICHE	40
PINZE PER CANALARI	190
PINZE PER CARTA DI ARTI.	214
PINZE PER DENTI DI LATTE	138
PINZE PER DISSEZIONE	28
PINZE PER ESTRAZIONE, AMER.	108
PINZE PER ESTRAZIONE, INGLESE	92
PINZE PER ESTRAZIONE BAMBIN	128
PINZE PER FORARE LA DIGA	207
PINZE PER GRAFFE	229,231
PINZE PER LEGATURE	32
PINZE PER LINGUA	89
PINZE PER MARCARE	38
PINZE PER SCHEGGIE	32

PINZA PER TAGLIATI CORONE	216
PINZE PER TESSUTI	44
PINZE PER UNCINI	207
PINZE PIATTE	224
PINZE PIEGA FILO	227,228
PINZE PIEGHE UNIVERSALE	232
PINZE SGORBIE	62,64
P. K. THOMAS	217
PLESTER	4
PORTA BRACKET	244
PORT'AGHI	54
PORT'AGHI, MICRO	59
PORTAIMPRONTE	210
PORTAMATRICI	205
PORTATOVAGLIOLI	90
POTT	148
PRICHARD	172
PROVIDENCE-HOSPITAL	42

R

REYNOLD	235
REYNOLDS	19
RIEGNER	221
ROACH	221
ROGGE	238
ROUTURIER	106
RYDER	56
RYDER VASCULAR	56
ROCHESTER-OCHSNER	43
ROCHESTER-PEAN	42
ROSER-KOENIG	87
ROUX	46
RUSKIN	64

S

SACHS	214
SANVENERO	15
SCALPELLI	79
SCALPELLI E SGORBIE	80
SCHAEDEL	43
SCHARMANN	170
SCHLUGER	173
SCHURE	214
SCHWARZ	212,228
SELDIN	74,76
SEMKEN	30
SENN	46
SEPARATORI PER GUANCIA	51,86
SHORTBENT	23
SICHEL	170
SIMPLEX	86
SINDESMOTOMI	153
SIRINGE DI CARPULE	156
SMITH	199
SONDE A BOTTONE	82
SONDE DENTALI	182
SPATOLE PER CEMENTO	203
SPATULE PER GESSO	212
SPAZZOLA PER UNGHIE	244
SPECCHIETTI DI BOCCA	162
STADLER	229
STRUMENTI PER AMALGAMA	195
STRUMENTI PER CORONE	214

STRUMENTI PER DIGA DI GOMMA	207
STRUMENTI PER STERILIZZAZIONE	238
STRUMENTI PER MODELARE	217
STRUMENTI PER MODELLARE	181
STRUMENTI PER OTTURAZIONE	197
SUGARMAN	173
SPENCER	23
STERNBERG	86
STEVENS	58
STIEGLITZ	32
STRANDELL-STILLE	47

T

TAGLIASMALTI	188
TAMPONATORI	90
TANNER	181,188
TAYLOR	31,171
TENAGLIE PER LEGATURE	234
TENAGLIE PER OSSA	65
TENAGLIE PER PROFILI	235
THOMAS	116
THUERRIEGEL	189
TOBOLD	85
TOENNIS	56
TOENNIS-ADSON	19
TOENNIS-ADSON FINO	19
TOFFLEMIRE	205
TOWNER-JACQUETTE	172
TREYMAN	215
TRIPLEX	235
TRYFUS	216
TUBI DI ASPIRAZIONE	2
TWEED	230

U

UNCINO PER LE PINNE NASALI	47
UNIVERSAL	24,26,232,238

V

VEHE	220
VIRTUS (RALK)	32
VITI PER RADICI	126
VOLKMANN	47,68

W

WAERHAUG	219
WAGNER	22
WAKEFILED	79
WALDSACHS-UNIVERSAL	232
WARD	51,219
WARWICK-JAMES	143,145,147
WEINGART	234
WEITLANER	52
WEST-APIVCAL	151
WESTCOTT	194
WEST HEIDBRINK-APIVCAL	151
WESTON	222
W. F. BARRY	149
WHITE	183,187,196,200

WIEDER	84
WILLIAM-FOX	180
WILLIAMS	199
WILLIGER	48,66,68,69,75,77,168
WINTER	150,152
WOOD	104
WOODSON	199,200
WOOD-WARD	109

Y

YOUNG	230
YOUNGER-GOOD	171,174

Z

ZAHLE	220
-------	-----

